

SHARP SERVICE MANUAL

CODE: 00ZAR505//A1E

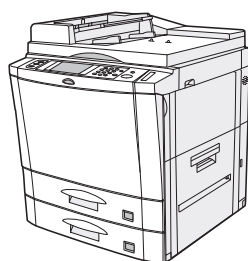

(AR-280/281)

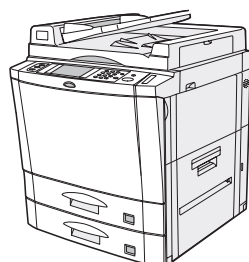

(AR-285/286/335/336)



(AR-405)

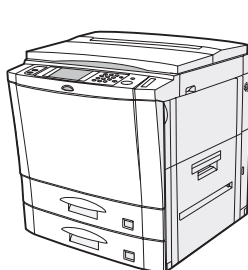

(AR-250)



(AR-501/505)

Digital Copier

AR-250

AR-280/281

AR-285/286

AR-335/336

AR-405

MODEL AR-501/505

CONTENTS

[1] GENERAL	1-1
[2] SPECIFICATIONS	2-1
[3] CONSUMABLE PARTS	3-1
[4] INSTALLATION AND SETUP	4-1
[5] EXTERNAL VIEW AND INTERNAL STRUCTURE	5-1
[6] SETTING AND ADJUSTMENTS	6-1
[7] SIMULATION	7-1
[8] DISASSEMBLY, ASSEMBLY, MAINTENANCE	8-1
[9] TROUBLE CODE LIST	9-1
[10] OPERATIONAL DESCRIPTION	10-1

Parts marked with "△" is important for maintaining the safety of the set. Be sure to replace these parts with specified ones for maintaining the safety and performance of the set.

[1] GENERAL

1. Features of copying functions

A. Touch panel

The touch panel with the back-lighted LCD simplifies various operations. It also shows operation descriptions and paper jam treatment.

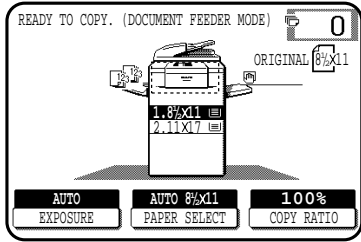

B. Various functions of digital system

Different from the conventional analog copiers, this machine employs the digital system where the image data of a document scanned by the CCD sensor (which converts photo signals into electrical signals) are converted into digital signals. This digital system allows the independent zooming copy, black-white reversing copy, and centering copy.

Independent zooming copy

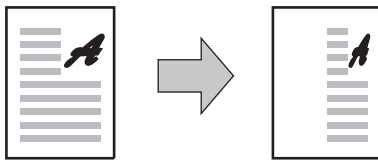

Black-white reversing copy

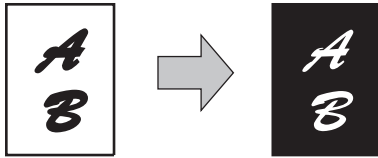

Centering copy

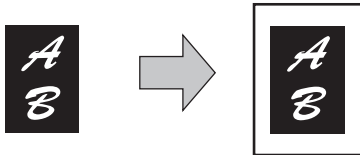

C. Front loading paper tray

The paper trays including the two-step paper feed desk employ a front loading system to facilitate paper loading.

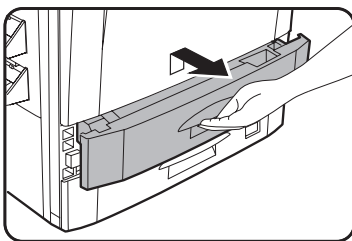

D. Automatic document feeder as standard provision

Without opening the document table cover, documents can be automatically fed and copied.

The automatic document feeder provided in the AR-280/285/286/335/336/405/501/505 allows automatic reversion of documents for duplex copying as well as simplex copying. (The automatic document feeder of the AR-280/281 allows only simplex copying.)

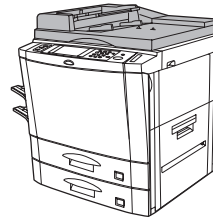

AR-280/285/335

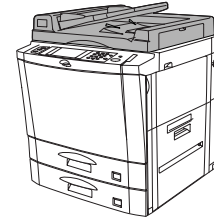

AR-286/336

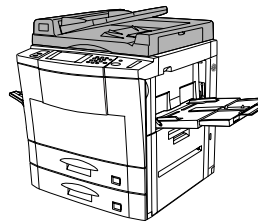

AR-405

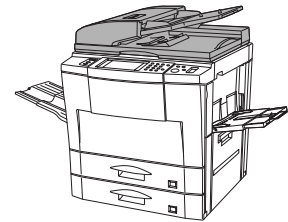

AR-501/505

E. Step zooming

The zooming function allows selection of the magnification ratio as follows.

	Magnification ratio	Increment	Steps
AR-280/281	25% to 200%	1%	176
AR-250/285/286/335/336	25% to 800%	1%	776
AR-405/501/505	25% to 400%	1%	376

F. Paper/magnification ratio auto selection

When the desired magnification ratio is specified, the suitable paper size is automatically selected by the original size detection function. If the copy paper size is specified, then the suitable magnification ratio is automatically selected.

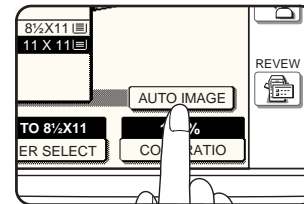

G. 1-set 2-copy

The right and the left pages of a book, etc. can be copied onto two sheets of paper continuously.

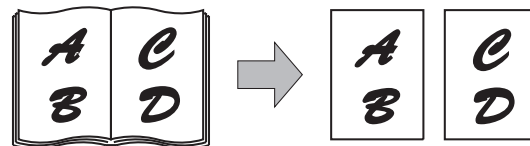

H. Edge erase copying

Shade at the copy edge can be automatically erased.

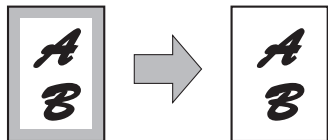

I. Binding margin copying

Copying with binding margin can be made.



J. Transparency film with insert sheets

When copying onto transparency film, insert sheets can be placed following each transparent sheet. The insert sheets can be processed blank or can be copied with the same image as the transparent sheets.

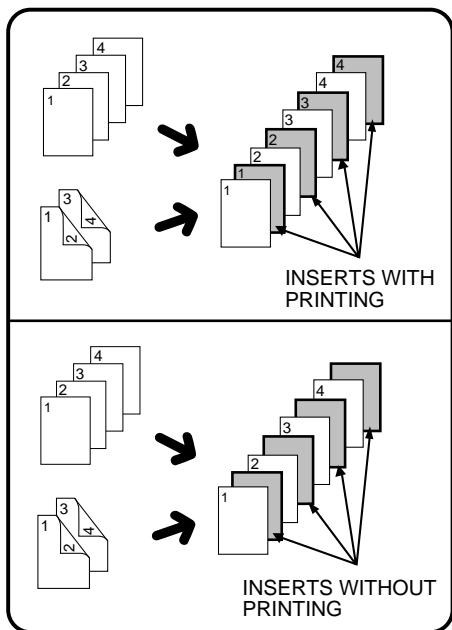

K. Copy conditions registration/recall

Nine sets of complicated copying procedures can be stored and recalled when necessary.

L. Key operator program

The key operator program is used by the key operator to set and cancel the customer functions.

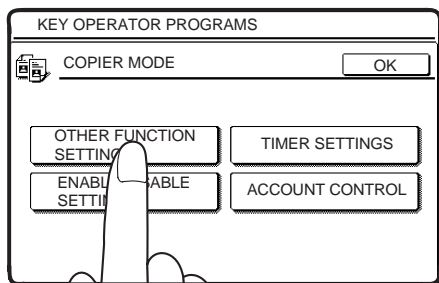

M. Auto duplex copy (AR-250/280/281 requires the option)

Duplex copy is made automatically.

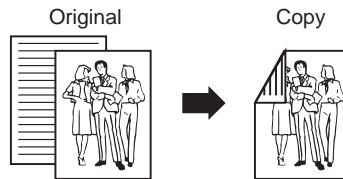

N. REPEAT COPY

The REPEAT COPY is used to produce repeated images from an original on to a single sheet of paper. Border lines can be drawn to separate repeated images.

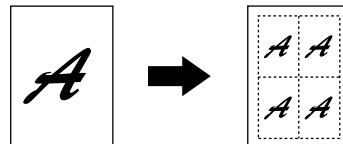

O. MULTI SHOT

The MULTI SHOT function is used to copy several originals, collectively in a specified order, onto one sheet.

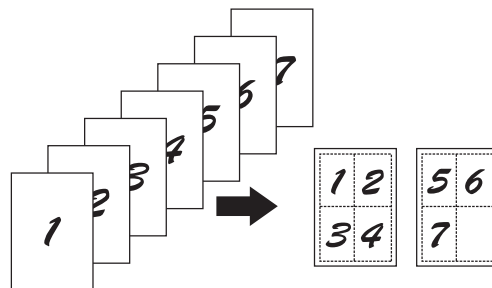

P. Hi-Fi copy (AR-280/285/335 only)

This function produces high image quality copies.

Q. DATE SIGN

The DATE SIGN function adds the current date to the copies. The date will be printed at the upper right of the copies.

R. WATERMARK

The WATERMARK function adds a selected watermark such as "CONFIDENTIAL" and "URGENT" to the copies. The watermark will be printed in gray tone at the center of copies.

S. SELECT STAMP

The SELECT STAMP function adds a selected string such as "CONFIDENTIAL" and "URGENT" to the copies. The string will be printed in white on a shaded background.

T. PAGE NUMBER

The PAGE NUMBER function adds page numbers to the copies.

2. System outline (Options)

Name	Model	Copier model									
		AR-250	AR-280	AR-281	AR-285	AR-286	AR-335	AR-336	AR-405	AR-501	AR-505
Automatic document feeder	AR-SP1	○	Standard	Standard	—	—	—	—	—	—	—
	RSPF	—	—	—	—	—	—	—	—	○	○
Reversing automatic document feeder	AR-RF1	○	—	—	○	○	Standard	Standard	—	—	—
	AR-RF2	—	—	—	—	—	—	—	Standard	—	—
Stand/500 sheet paper drawer	AR-DE1	○	○	○	○	○	○	○	—	—	—
	AR-DE1N	○	○	○	○	○	○	○	○	—	—
	AR-DE7	—	—	—	—	—	—	—	—	○	○
Large capacity tray	AR-LC1	○	○	○	○	○	○	○	○	—	—
	AR-LC1N	—	○	○	○	○	○	○	○	○	—
500-sheet paper drawer	AR-CS1	○	○	○	○	○	○	○	○	—	—
	AR-CS3	—	—	—	—	—	—	—	—	○	○
Desk	AR-DD1	○	○	○	○	○	○	○	○	—	○
	AR-DD1N	—	—	—	—	—	—	—	—	—	—
2-tray paper exit unit	AR-DU1	○	○	○	—	○	—	○	—	—	—
Exit tray	AR-TE1	○	—	○	○	○	○	○	—	○	○
Dual tray output unit	AR-TR1	○	—	○	—	○	—	○	○	—	—
Finisher	AR-FN1	○	○	○	○	○	○	○	○	—	—
	AR-FN1N	○	○	○	○	○	○	○	○	○	—
	AR-FN2	○	○	○	○	○	○	○	○	○	—
	AR-FN3	—	—	—	—	—	—	—	—	—	○
Printer board	AR-PB2	○	○	○	○	○	○	○	○	—	○
	AR-SM1	—	—	—	—	—	—	—	—	—	○
NIC card (10 base T/2)	JX96NCE8	○	○	○	○	○	○	○	○	—	○
	AR-NC1D	○	○	○	○	○	○	○	○	—	○
NIC card (10 base T/100 base TX)	AR-NC3D	○	○	○	○	○	○	○	○	—	○
	AR-NC4D	—	—	—	—	—	—	—	—	—	—
AXIS fixing angle	(AXIS scanner)	○	—	○	—	○	—	○	○	—	○
1GB-HDD	AR-HD1	○	—	—	—	—	—	—	—	—	—
Mounting kit	AR-XB3	—	—	○	—	○	—	○	○	—	—
Document cover	AR-VR2	○	—	—	—	—	—	—	—	—	—
Tandem connection cable	AR-CA1	—	—	—	—	—	—	—	—	—	○

AR-250

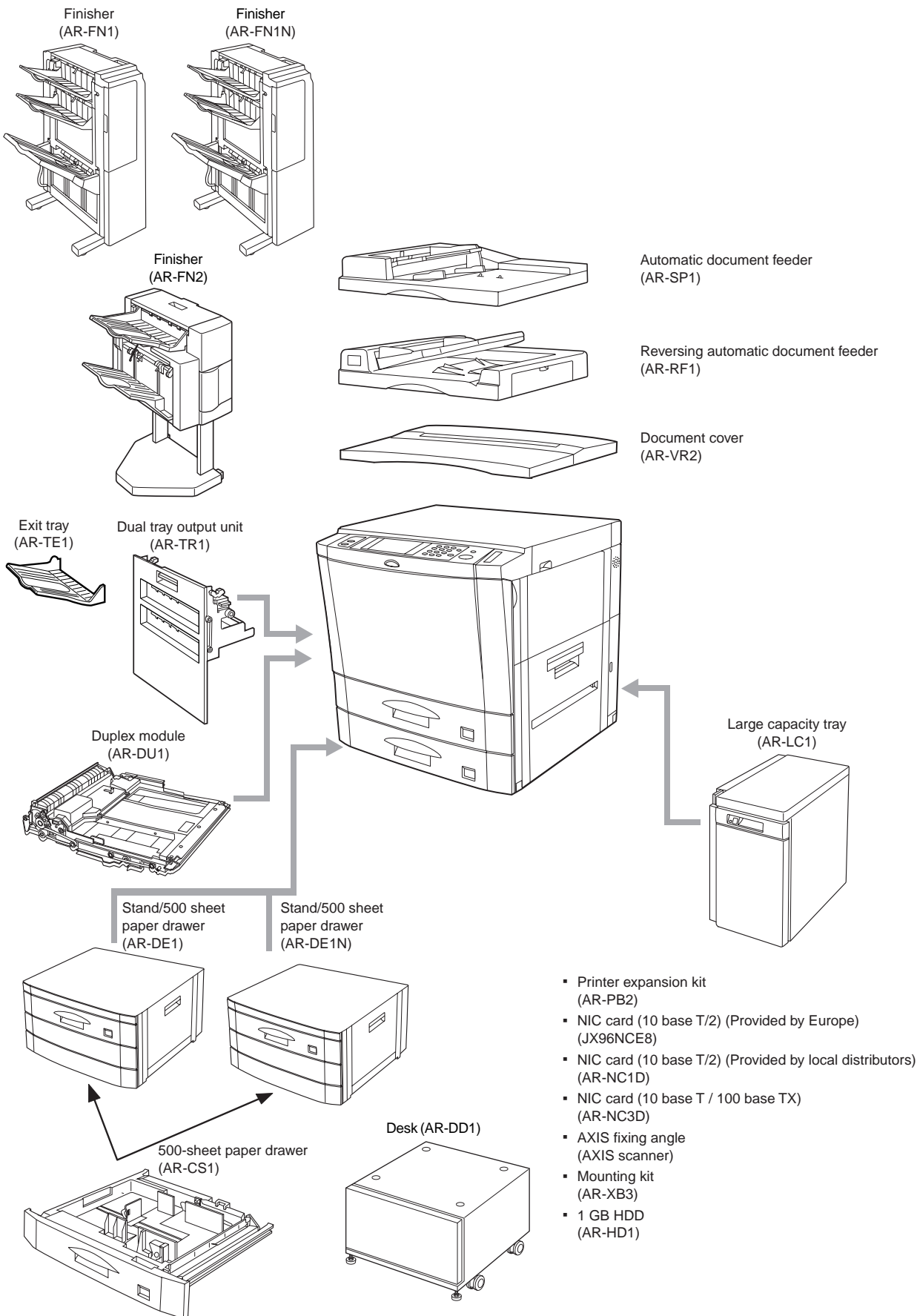

AR-280/285/335

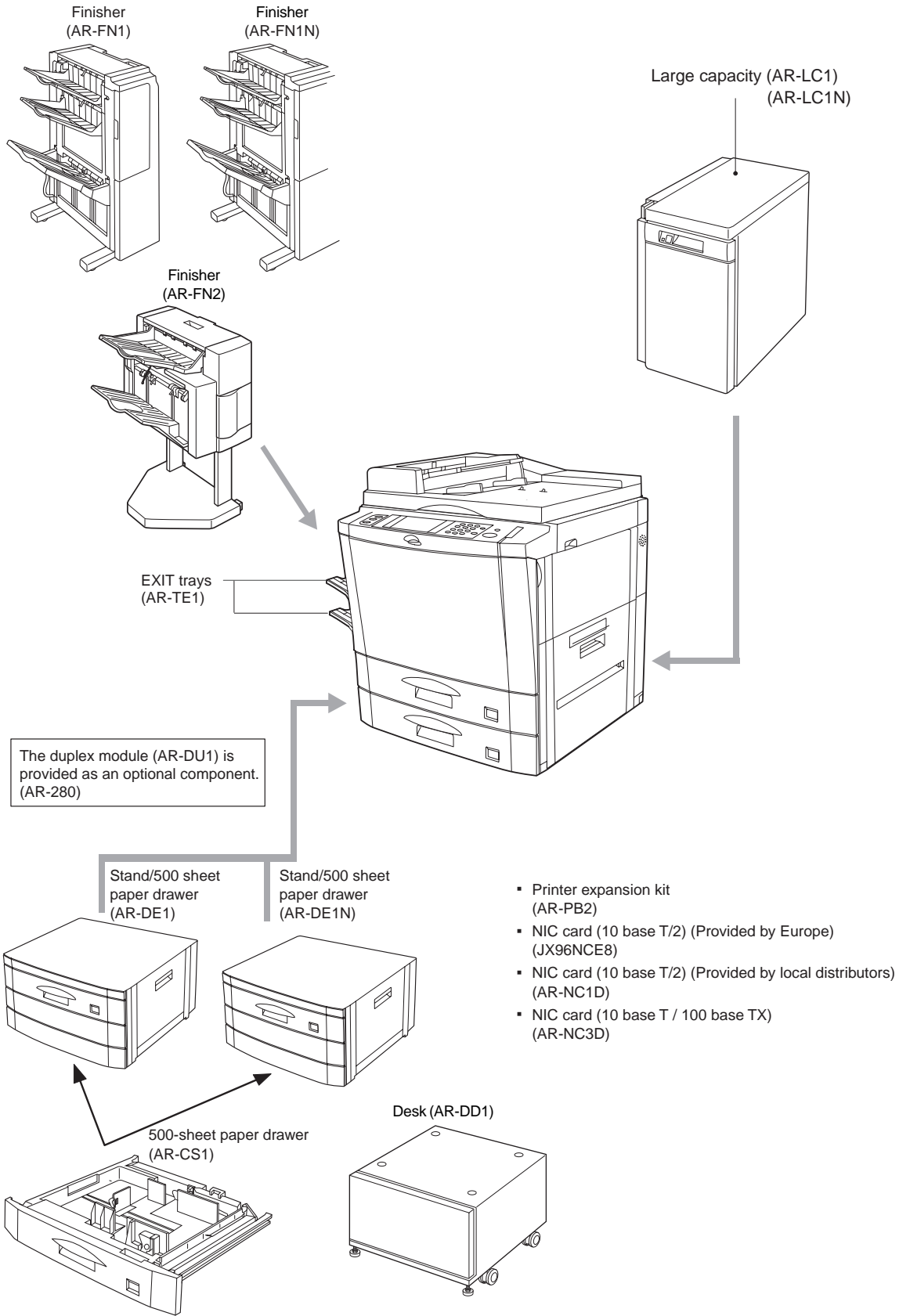

AR-281/286/336

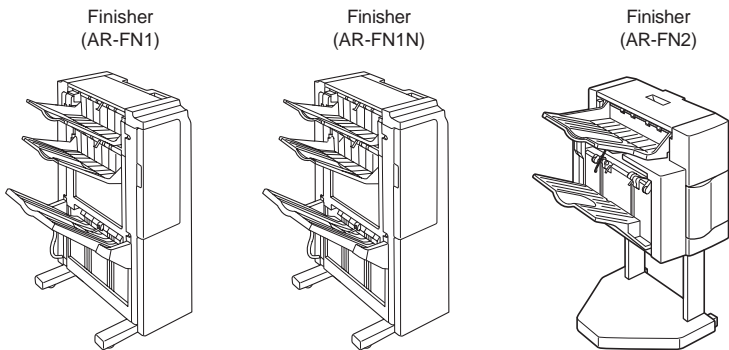

AR-281

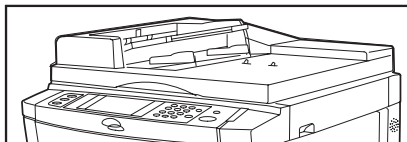

AR-286/336

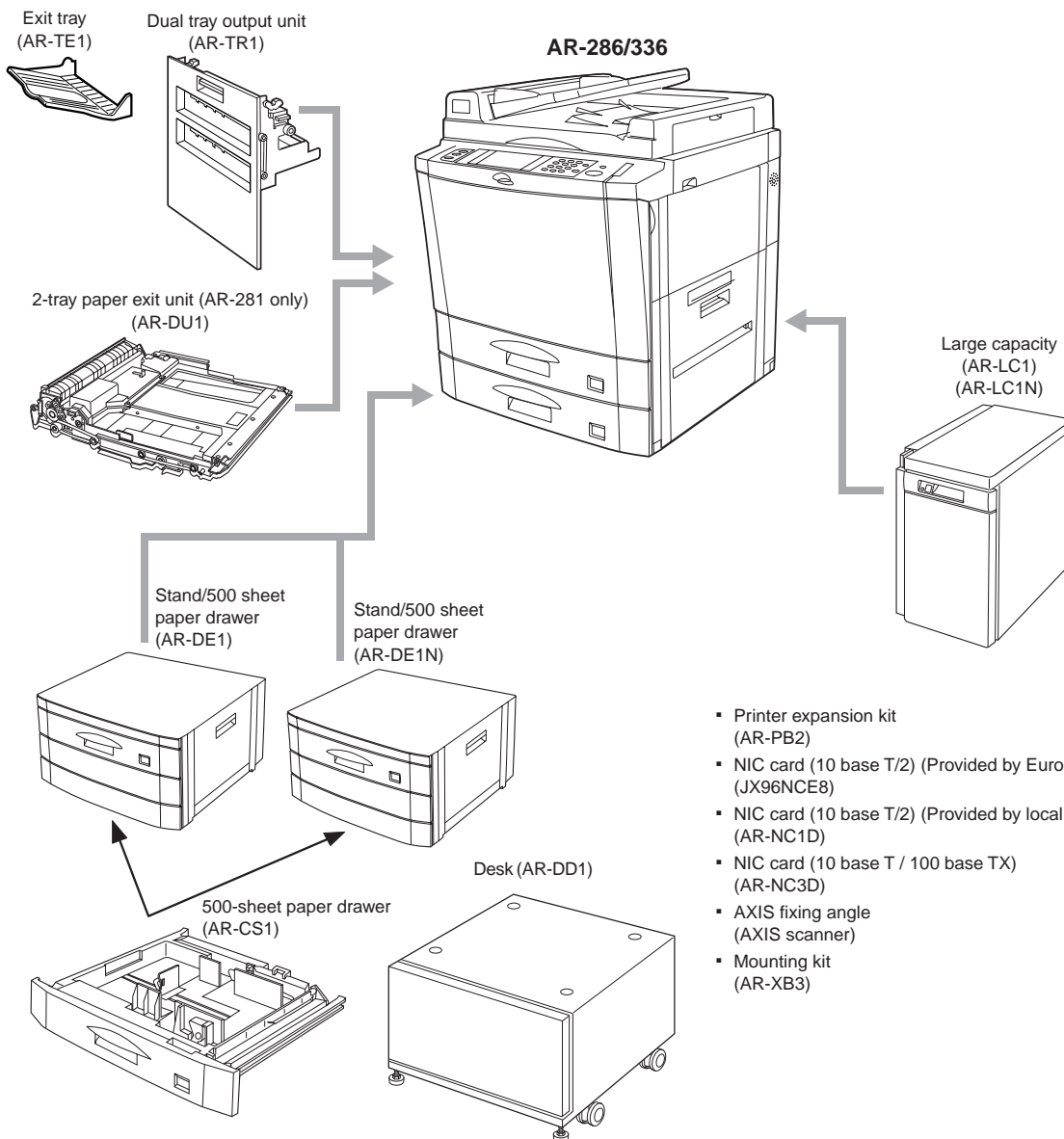

- Printer expansion kit (AR-PB2)
- NIC card (10 base T/2) (Provided by Europe) (JX96NCE8)
- NIC card (10 base T/2) (Provided by local distributors) (AR-NC1D)
- NIC card (10 base T / 100 base TX) (AR-NC3D)
- AXIS fixing angle (AXIS scanner)
- Mounting kit (AR-XB3)

AR-405

Finisher (AR-FN1N)

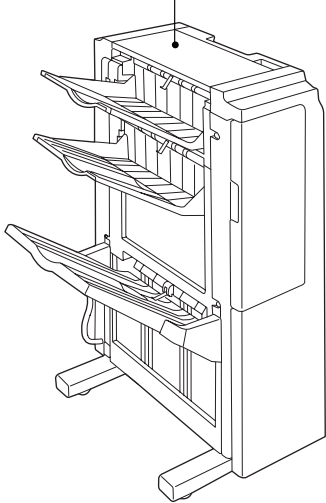

Finisher (AR-FN2)

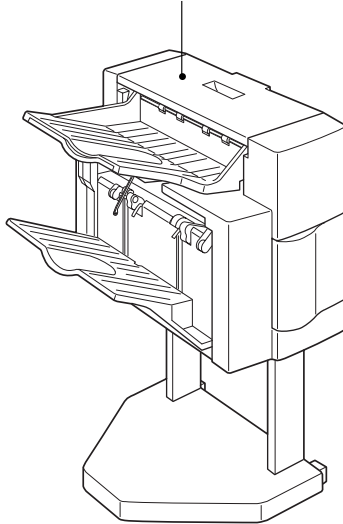

Large capacity tray (AR-LC1)
(AR-LC1N)

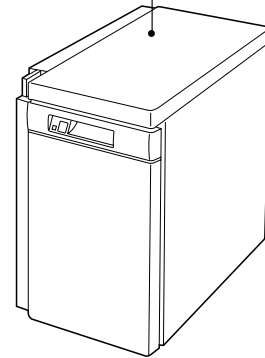

Exit tray
(AR-TE1)

Dual tray output unit
(AR-TR1)

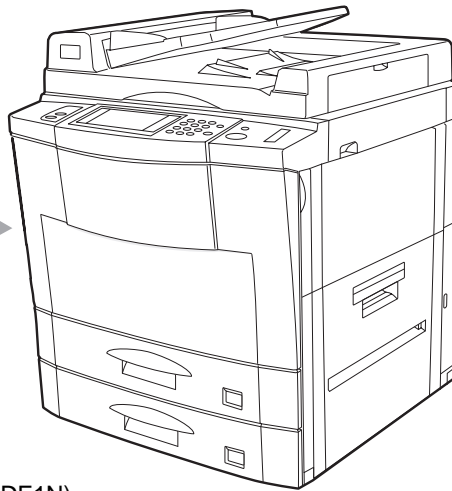
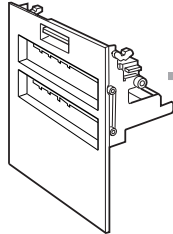

Stand/500-sheet paper drawer (AR-DE1N)

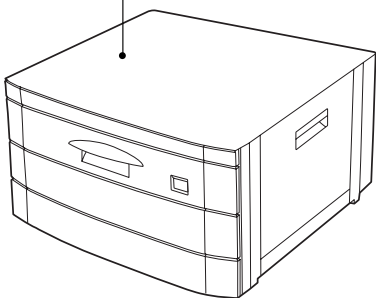

500-sheet paper drawer (AR-CS1)

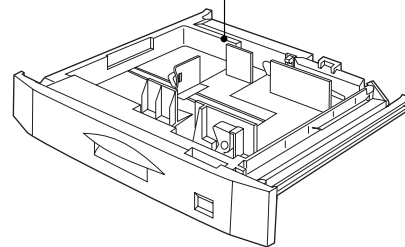

Desk (AR-DD1)

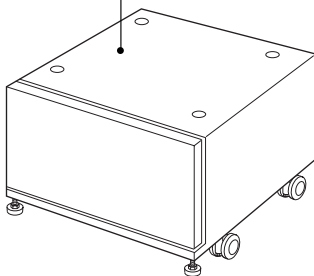

- Printer board (AR-PB2)
- NIC card(10baseT/2) (Provided by Europe) (JX96NCE8)
- NIC card (10baseT/2) (Provided by Europe) (AR-NC1D)
- NIC card (10baseT/100baseTX) (AR-NC3D)
- AXIS fixing angle (AXIS scanner)
- Mounting kit (AR-XB3)

AR-501/505

Finisher (AR-FN3)

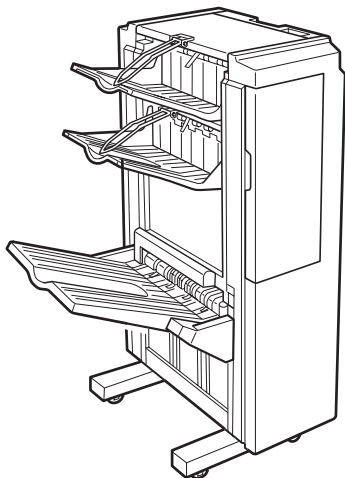

Large capacity tray (AR-LC1N)

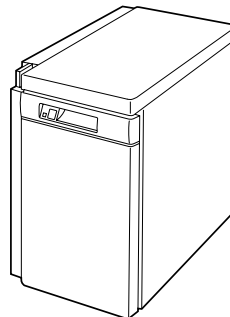

Exit tray (AR-TE1)



Dual tray output unit (AR-TR1)

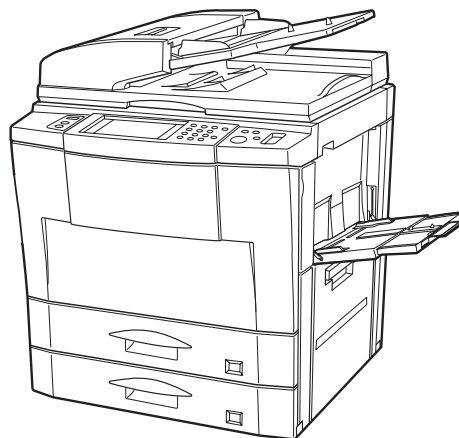
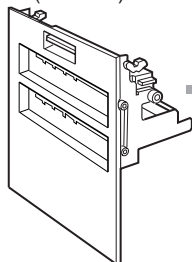

Stand/500-sheet paper drawer (AR-DE7)

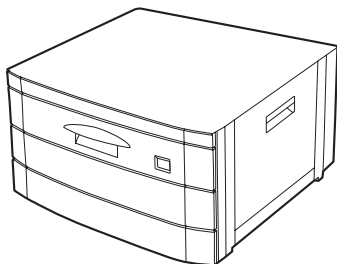

500-sheet paper drawer (AR-CS3)

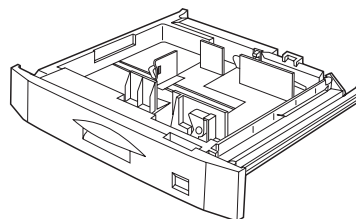

Desk (AR-DD1)

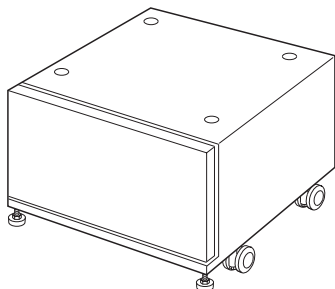

AR-505 only

- Printer board (AR-PB2)
- NIC card (10baseT/2) (Provided by Europe) (JX96NCE8)
- NIC card (10baseT/2) (Provided by Europe) (AR-NC1D)
- NIC card (10baseT/100baseTX) (AR-NC3D)
- Printer board (Expansion memory 16MB x2 SIM) (AR-SM1)
- AXIS fixing angle (AXIS scanner)
- Tandem connection cable (AR-CA1)

3. Installation requirements

To ensure safety and proper machine performance, please note the following before initial installation and whenever the machine is to be relocated.

- 1) The copier should be installed near an accessible power outlet for easy connection.
- 2) Be sure to connect the power cord only to a power outlet that meets the specified voltage and current requirements.
Also make certain the outlet is properly grounded.

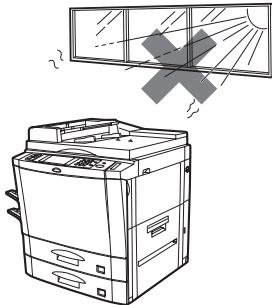

- 3) Do not install the machine where it is:

- damp or humid,
- exposed to direct sunlight,
- extremely dusty,
- poorly ventilated,
- subject to extreme temperature or humidity changes (e.g., near an air conditioner or heater).

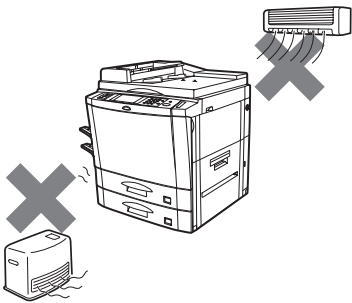

- 4) Since a hard disk drive is built into this copier, place the copier on a firm, level surface. Choose an area which is not subject to any vibration.

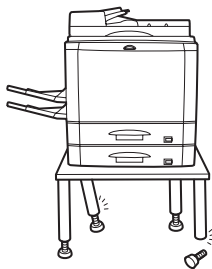

- 5) Be sure to allow the required space around the machine for servicing and proper ventilation.

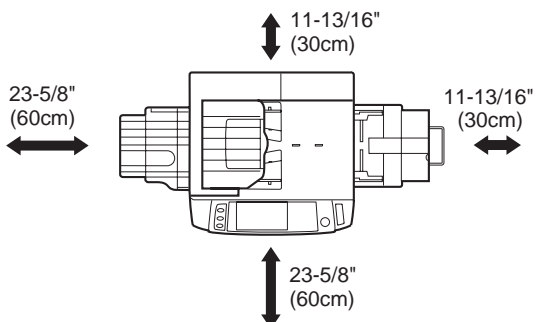

A small amount of ozone is produced within the copier during operation. The emission level is insufficient to cause any health hazard.

NOTE: The present recommended long term exposure limit for ozone is 0.1 ppm (0.2 mg/m³) calculated as an 8 hr. time-weighted average concentration.

However, since the small amount that is emitted may have an objectionable odor, it is advisable to place the copier in a ventilated area.

Cautions

- 1) Do not touch the photoconductive drum. Scratches or smudges on the drum will cause dirty copies.
- 2) The fusing unit is extremely hot. Exercise care in this area.
- 3) Since a hard disk drive is built into the copier, be sure to turn the power switch to the "OFF" position when moving the copier. Take care not to subject the copier to any vibration or shock.

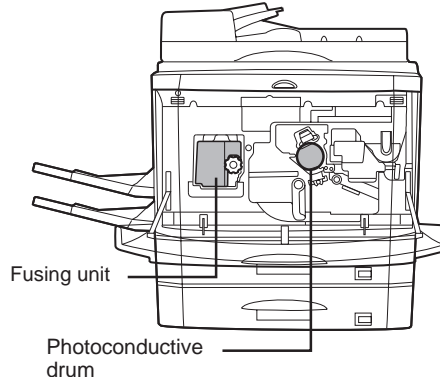

- 4) Do not look directly at the light source. Doing so may damage your eyes.

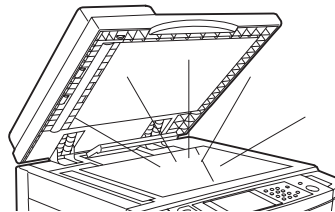

- 5) Installation adjusters are provided on the optional stand/500-sheet paper drawer. When moving the machine with the optional stand/500-sheet paper drawer, be sure to raise the installation adjusters. After moving the machine, lower the installation adjusters until they reach the floor to lock the machine in place. (If the casters are not locked securely, the machine will gradually move and the cables of the RADF and the SPF are rubbed against the wall, causing internal disconnection.)

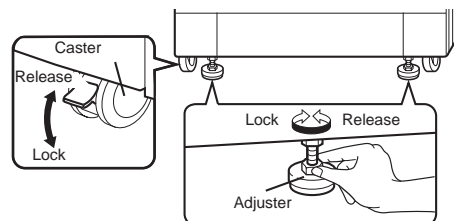

- 6) When copying is interrupted (for example, because the INTERRUPT function has been used, paper or toner has run out, a misfeed has occurred, etc.), this copier will store the image data of the originals read prior to the interruption. If copying of secret documents is interrupted due to the above reasons, be sure to either resume the interrupted copying by pressing the START key, or clear the image data by pressing the clear all key after the interrupt copying is completed or the trouble is cleared, because the stored data may be printed by other operators.

[2] SPECIFICATIONS

1. Machine type

Product Name	CPM	Type		Document Feeder	Paper Exit	Memory	
						RAM	HD
AR-250	25	Simplex	Desk top	—	1 tray	48 MB	—
AR-280	28	Simplex	Desk top	SPF	2 tray	16 MB	1 GB
AR-281	28	Simplex	Desk top	SPF	1 tray	16 MB	2 GB
AR-285	28	Duplex	Desk top	RADF	2 tray	16 MB	1 GB
AR-286	28	Duplex	Desk top	RADF	1 tray	16 MB	2 GB
AR-335	33	Duplex	Desk top	RADF	2 tray	16 MB	1 GB
AR-336	33	Duplex	Desk top	RADF	1 tray	16 MB	2 GB
AR-405	40	Duplex	Desk top	RADF	1 tray	16 MB	2 GB
AR-501	50	Duplex	Desk top	RSPF	1 tray	48 MB	2 GB
AR-505	50	Duplex	Desk top	RSPF	1 tray	48 MB	2 GB

* Memory capacity is of the main body only, excluding optional expansion memory.

2. Copy speed

A. Basic Speed

per 1 scan	AR-250	AR-280 AR-281	AR-285 AR-286	AR-335 AR-336	AR-405	AR-501 AR-505
Single	25 cpm	28 cpm	28 cpm	28 cpm	34 cpm	47 cpm
Multiple	25 cpm	28 cpm	28 cpm	33 cpm	40 cpm	50 cpm

* Speeds from all the paper feed ports including the normal copy and the manual feed copy.

B. Normal copy (100%)

	AR-250	AR-280 AR-281	AR-285 AR-286	AR-335 AR-336	AR-405	AR-501 AR-505
A4/8.5 × 11	25	28	28	33	40	50
A3/11 × 17	13	14	14	17	19	25
B4/8.5 × 14/ 8.5 × 13	15	17	17	21	24	29
B5/A5/ 8.5 × 5.5	25	28	28	33	40	50
A4R/B5R/ 8.5 × 11	18	20	20	24	27	35

C. Enlargement copy

	AR-250	AR-280 AR-281 (800%)	AR-285 AR-286 (800%)	AR-335 AR-336 (800%)	AR-405 (400%)	AR-501 AR-505 (400%)
A4/8.5 × 11	25	28	28	33	40	50
A3/11 × 17	13	14	14	17	19	25
B4/8.5 × 14/ 8.5 × 13	15	17	17	21	24	29
B5/A5/ 8.5 × 5.5	25	28	28	33	40	50
A4R/B5R/ 8.5 × 11	18	20	20	24	27	35

D. Reduction copy (25%)

	AR-250	AR-280 AR-281	AR-285 AR-286	AR-335 AR-336	AR-405	AR-501 AR-505
A4/8.5 × 11	25	28	28	33	40	50
A3/11 × 17	13	14	14	17	17	25
B4/8.5 × 14/ 8.5 × 13	15	17	17	21	24	29
B5/A5/ 8.5 × 5.5	25	28	28	33	40	50
A4R/B5R/ 8.5 × 11	18	20	20	24	27	35

E. First Copy time

(1) Basic Speed

Model	AR-250	AR-280 AR-281	AR-285 AR-286	AR-335 AR-336	AR-405	AR-501 AR-505
Speed (sec.)	5.2	5.2	5.2	5.2	4.5	4.3

When the paper is fed from the Upper tray on the base unit.

Machines are measured when paper is fed from the upper tray of 2-tray exit unit.

(2) Detail

	AR-250	AR-280 AR-281	AR-285 AR-286	AR-335 AR-336	AR-405	AR-501 AR-505
Upper cassette (sec.)	5.2	5.2	5.2	5.2	4.5	4.3
Lower cassette (sec.)	5.7	5.7	5.7	5.7	5.0	4.5
Multi-Bypass Tray (sec.)	5.3	5.3	5.3	5.3	4.6	4.3
Stand/Upper paper drawer (sec.)	6.6	6.6	6.6	6.6	5.9	5.2
Stand/Medium paper drawer (sec.)	6.9	6.9	6.9	6.9	6.2	5.5
LCC (sec.)	5.9	5.9	5.9	5.9	5.2	4.7

Refer to each specification for the first copy time when paper is fed from the document feeder or the optional paper feed tray.

(3) First copy time from the document feeder

Model	AR-250 AR-281 AR-286	AR-280	AR-285 AR-335 AR-336	AR-405	AR-501 AR-505
When the SPF is used (sec.)	7.8	7.8	—	—	—
When the RADF is used (sec.)	8.8	—	8.8	7.6	—
When the RSPF is used (sec.)	—	—	—	—	7.0

When the paper is fed from the Upper tray on the base unit.

3. OC/DF

A. Document table

Max. document size	A3/11 × 17	
Document reference position	Center left	
Document detection	Yes	
Detection size	Inch Series	11 × 17, 8.5 × 14, 8.5 × 11, 8.5 × 11R, 8.5 × 5.5
	AB Series	A3, B4, A4, A4R, A5
	Australia	A3, 216 × 330, A4, A4R, A5 (Note 1)
	B5 areas	A3, B4, A4, A4R, B5, B5R
OR guide display	Inch Series	11, 8.5, 5.5
	AB Series	A3/A4, B4/B5, A4R/A5, B5R, 11, 8.5 (Note 2)

(Note 1) For areas other than Australia, "B4/8.5 × 11" can be changed to "8.5 × 13" by the simulation.

(Note 2) The display of 8.5" for AB series is of the line display only. There is no size display.

B. SPF (AR-280/281)

(1) Document set

Set direction	Face down		
Set position	Center reference		
Set quantity	A4/8.5 × 11	30 sheets	30 sheets of 80g/m ² must be set. For 80 ~ 128g/m ² , paper of max. 4.7mm thick can be set.
	Greater than the above.	15 sheets	

(2) Document transport

Document transport system	Sheet through type
Document feed sequence	Top take-up feed

(3) Document Size

Document Size	AB Series	A3 ~ A5
	Inch Series	11 × 17 ~ 8.5 × 5.5
Paper Weight	50 ~ 128g/m ² (14 ~ 34 lbs.)	

(4) Multi quantity

Multi quantity	In the high fidelity mode, multi copy is inhibited.
----------------	---

(5) Document mix feed

Mix paper feed	Allowed.
Random paper feed	Not allowed.

No linkage with AMS is made.

(6) Document detection

Detection size	Inch Series	11 × 17, 8.5 × 14, 8.5 × 11, 8.5 × 11R, 8.5 × 5.5
	AB Series	A3, B4, A4, A4R, A5
	Australia	A3, A4, A4R, A5, 216 × 330 (Note 1)
Document guide display	Inch Series	11, 8.5, 5.5
	AB Series	A3/A4, B4/B5, A4R/A5, B5R, 8.5 (Note 2)

(Note 1) For areas other than Australia, "B4/8.5 × 11" can be changed to "8.5 × 13" by the simulation.

(Note 2) The display of 8.5" for AB series is of the line display only. There is no size display.

(7) Stream mode

Stream mode	The stream mode can be selected by the key operation program. (Only group mode)
-------------	---

(8) Document reverse

Document reverse	No
------------------	----

(9) Display section

Display section	No
-----------------	----

C. RADF (AR-285/286/335/336/405)**(1) Document set**

Set direction	Face up		
Set position	Center reference		
Set quantity	A4/8.5 × 11	50 sheets	35 ~ 80g/m ² : Thickness Less than 6.5 mm
	Greater than the above	30 sheets	80 ~ 128g/m ² : Thickness Less than 5 mm (50 sheets of 80g/m ²)

(2) Document transport system

Document transport system	Belt system
Document fed sequence	Lower take-up paper feed (Face up paper feed)

(3) Document size

Document size	AB Series	A3 ~ A5
	Inch Series	11 × 17 ~ 8.5 × 5.5
Weight	35 ~ 128g/m ² (10 ~ 34 lbs.)	

(4) Document stop system

Document stop system	Stopper system (Position control for single copy) (Duplex copy)
----------------------	---

(5) Document detection on the tray

Document detection on the tray		Yes
Detection size	Inch Series	11 × 17, 8.5 × 14, 8.5 × 11, 8.5 × 11R, 8.5 × 5.5, 8.5 × 13
	AB Series	A3, B4, A4, A4R, A5, 8.5 × 13
	B5 area	A3, B4, A4, A4R, B5, B5R, A5
	Australia	A3, B4, A4, A4R, A5, 216 × 330
Document guide display	Inch Series	11, 8.5, 5.5
	AB Series	A3/A4, B4/B5, A4R/A5, B5R, 8.5 (Note)

(Note) AB series 8.5" display is of line display only. Size display is not made.

When setting Sim, "8.5 × 14" and "8.5 × 13" are separately detected.

(7) Document mix feed

Document mix feed	Mix paper feed	Possible (Same width size)
	Random paper feed	Possible

No linkage with AMS is made.

(8) Document reversion

Document reversion	Yes
--------------------	-----

(9) Display

Display section	LED display	Document feed display section
		Document remaining display

(10) Stream mode

Stream mode	The stream mode can be selected by the key operation program. (Only group mode)
-------------	---

D. RSPF (AR-501/505)**(1) Document set**

Set direction	Face up	
Set position	Center reference	
Set quantity	Less than 80g/m ²	50 sheets
	Greater than the above	Thickness Less than 6 mm

(2) Document transport

Document transport system	Sheet through type
Document feed sequence	Top take-up feed

(3) Document size

Document Size	AB Series	A3 ~ A5
	Inch Series	11 × 17 ~ 8.5 × 5.5
Paper Weight	Simplex	50 ~ 128g/m ² (14 ~ 34 lbs.)
	Duplex	50 ~ 110g/m ² (14 ~ 29 lbs.)

(4) Document detection

Detection size	Inch Series	11 × 17, 8.5 × 14, 8.5 × 11, 8.5 × 11R, 8.5 × 5.5
	AB Series	A3, B4, A4, A4R, A5, B5, B5R

(5) Others

Dimensions (W x D x H)	576 x 505 x 142 mm
Weight	About 13.5 kg
Super supply	DC 24V, DC 5V (Supplied from main body)
Zooming ratio	100 to 400%
Document exchange speed	Max. 50 sheets/minute
Power consumption	DC24V: 48W, DC5V: 2W

4. Paper feed

A. Outline of paper feed

Copy size (Max. ~ Min.)	AB Series	A3 ~ A6R, Postcard
	Inch Series	11 × 17 ~ 8.5 × 5.5
Paper feed system	2 Tray + Manual Feed Tray	
Paper feed capacity	500 × 2 + 50 (80g/m ²)	
Remaining detection	Paper feed tray section	Level detection available 0~ 25%, 25%~ 50%, 50%~ 85%, 85%~
	Manual Feed Tray	Empty detection only available

B. Details of paper feed section

(1) Paper feed tray

Paper feed size	AB Series	A3/B4/A4/A4R/B5/B5R/A5
	Inch Series	11 × 17/8.5 × 14/8.5 × 13/ 8.5 × 11/8.5 × 11R/5.5 × 8.5
Paper weight	56 ~ 105g/m ² (15 ~ 28 lbs.)	
Paper size selection	User operation (slide switch system)	
Slide switch	AB Series	A5/A4/A4R/B4/A3/B5/8.5 × 11/ EXTRA
	Inch Series	11 × 17/8.5 × 14/8.5 × 13/8.5 × 11/ 8.5 × 11R/5.5 × 8.5/A4/EXTRA
Cassette attachment/detachment	Only the lower cassette possible	

When the slide switch is set to "Special", the operation is made on the set size of the key operator program.

(Sizes of 13" in AB series and B5 are set with the key operator program.)

(2) Manual Feed Tray

Manual feed tray type	Folding, complete attachment	
Paper size	AB Series	A3 ~ A6R
	Inch Series	11 × 17 ~ 8.5 × 5.5
	Paper Weight	52 ~ 128g/m ² (14 ~ 34 lbs.), 176g/m ² (index paper), 200g/m ² (cover paper) (For greater than 105g/m ² , 28lbs, the size is A4 or smaller. For greater than 128g/m ² (34 lbs) portrait feed only.
Paper kind	Multi feed	Standard paper, special paper
	Single feed	Standard paper, special paper, No. 2 original paper
	Special paper	OHP, label paper, reproduction paper, index paper, cover paper For multi and back surface copy, only the single paper feed is allowed.
Detection size	AB Series	A3/B4/A4/A4R/B5/B5R/A5/A6R
	Inch Series	11 × 17/8.5 × 14/8.5 × 11/ 8.5 × 11R/5.5 × 8.5/7.25 × 10.5
Manual feed tray guide display	AB Series	A3/A4, B4/B5, A4R/A5, A5R, B5R, 11, 8.5 (NOTE 1)
	Inch Series	11, 8.5, 5.5

(Note 1) For 11" × 8.5" of AB series, only the line is displayed and the size is not displayed.

(3) Dehumidifying heater

Yes/No	No
--------	----

5. Multi copy

Multi max. quantity	999
---------------------	-----

6. Warm up

	AR-250/280 /281/285/ 286/335/336	AR-405	AR-501/505
Warm up time	Less than 65 sec	Less than 75 sec	About 150 sec
Pre-heat yes/no	Yes		
Jam recovery time	About 10sec (Leaving the machine for 60 sec after opening the door, standard condition, polygon stop.)		About 30 sec

7. Copy magnification ratio

Fixed magnification ratio	AB Series	AR-250/280/281/ 285/286/335/336	AR-405/501/505
		25, 50, 70, 81, 86, 100, 115, 122, 141, 200, 400, 800%	25, 50, 70, 81, 86, 100, 115, 122, 141, 200, 400%
	Inch Series	5R + 6E	
		25, 50, 64, 77, 95, 100, 121, 129, 141, 200, 400, 800%	25, 50, 64, 77, 95, 100, 121, 129, 141, 200, 400%
Zoom width		25 ~ 800%	25 ~ 400%
Independent magnification width		25 ~ 800% for horizontal/vertical (25 ~ 800% high fidelity copy))	25 ~ 400% for horizontal/vertical

8. Exposure

Exposure mode	Auto, character, character/photo, photo	
Manual steps	9 steps	
Resolution	Read	400 dpi
	Write	600 dpi
Gradation	Read	256 gradations
	Write	2 gradations (Default)
Toner save mode	Set with the key operator program. (In U.K., it is treated by a serviceman.)	

9. Print area

A. Max. print area

Max. area	AB Series	416 × 293 mm
	Inch Series	428 × 275 mm

B. Loss width

Void area	AR-501 AR-505	Lead edge 4 mm or less, rear edge 4 mm or less, FR total 5 mm or less
	Other models	Lead edge 3 mm or less, rear edge 4 mm or less, FR total 5 mm or less
Image Loss	Less than 5 mm	

10. Paper exit

A. Paper exit form

	AR-280/285/335	AR-250/281/286/336/ 405/501/505
Paper exit form	2-tray paper exit	1-tray paper exit

B. Paper exit section

		AR-280/285/ 335	AR-250/281/ 286/336/ 405	AR-501/505
Paper exit tray capacity	Upper Tray	250 sheets		
	Lower Tray	100 sheets	—	
Paper exit surface (Face up/Face down)	Upper Tray	Face up		Face up & Face down
	Lower Tray	Face up	—	

C. Paper size

		Size	Paper Weight
Upper Tray	AB Series	A3 ~ A6R	50 ~ 128g/m ² , 176g/m ² , 200g/m ²
	Inch Series	11 × 17 ~ 8.5 × 5.5	
Lower Tray	AB Series	A3 ~ A5	50 ~ 105g/m ²
	Inch Series	11 × 17 ~ 8.5 × 5.5	

Duplex pass section : 56 ~ 105g/m²**11. Duplex module
(AR-285/AR-335/336/405/501/505)****A. Auto duplex unit**

	AR-250/280/281	AR-285/286/335/ 336/405/501/505
Auto Duplex Unit	Option (AR-DU1)	Standard

B. Paper size

Paper size	AB Series	A3, B4, A4, A4R, B5, B5R, A5
	Inch Series	11 × 17, 8.5 × 14, 8.5 × 13, 8.5 × 11, 8.5 × 11R, 7.25 × 10.5R
Paper Weight	56 ~ 105g/m ² (Same as the paper feed section of the main body)	

C. Capacity

Capacity	1 Sheet (Single Pass Method)
----------	------------------------------

12. Shipping form**A. Packing form**

Body	Body/accessories
------	------------------

B. Paper size

First Tray	AB Series	A3
	Inch Series	11 × 17
Second Tray	AB Series	A3
	Inch Series	11 × 17

13. Additional functions**A. Main body functions**

APS	
AMS	AMS by flow scan with DF is not allowed.
Auto tray switching	
1 scan multi copy	
Rotation copy	
Pre-heat	Conditions are set with the key operation.
Auto shut off	Conditions are set with the key operation.
Message display	
Key operator program	
Communication (RIC)	
Process control	
Coin vendor	Only the connector is provided on the PWB.

B. Copy function

	AR-250/280/281/ 285/286/335/336	AR-405	AR-501/505
Job call/ registration	9		
Dept. control	Max. 50 dept.	Max. 500 dept. (Only the copy function is controlled.)	
Binding margin	Shift width AB series: 10mm, Inch series: 1/2" with adjustment (Binding direction selectable)		
Edge erase	AB series: 10mm, Inch series: 1/2" with adjustment		
Center erase			
1-set, 2-copy			
Independent zooming	25 ~ 800% for vertical/horizontal	25 ~ 400% for vertical/horizontal	
White/black reversion	All surface only (only in the manual mode)		
Cover paper	Cover/back cover/cover and back cover		
OHP insert paper	Insert paper copy Yes/No selectable	Only 1 face-up paper exit is possible	
Centering			
Multi shot (Nin1)	Paper feed size is up to A4.		
Repeat copy			
Date print	Time setting by the key operation.		
Stamp function			
Middle binding	HD is required for AR-250.		
Page print	HD is required for AR-250.		

14. Options

		AR-250	AR-280	AR-285 AR-335	AR-336 AR-405	AR-501 AR-505
Document feeder	SPF	Option	Standard	—	—	—
	RADF	Option	—	Standard	Standard	—
	RSPF	—	—	—	—	Standard
Paper feed	1 tray desk (AR-DE1)	Option	Option	Option	Option	Option (AR-DE7)
	Large capacity tray (AR-LC1)	Option	Option	Option	Option	Option (AR-LC1N)
	Tray module (AR-CS1)	Option	Option	Option	Option	Option
	Desk (AR-DD1)	Option	Option	Option	Option	Option
Duplex module	Auto duplex module (AR-DU1)	Option	Option	Standard	Standard	Standard
Finishing	Dual tray output unit (AR-TR1)	Option	Standard	Standard	Option	—
	Finisher (AR-FN1)	Option	Option	Option	Option	—
	Finisher (AR-RN2)	Option	—	—	Option	—
	FN3	Option	—	—	—	Option

15. Other specifications

Photoconductor kind	OPC drum
Photoconductor dia.	65 φ
Process cleaning	Blade
Exposure lamp	No-electrode xenon lamp
Developing system	Dry, 2-component magnetic brush development
Charging system	DC negative scorotron (saw tooth electrode)
Transfer system	DC positive control
Separation system	AC corotron/DC bias separation pawl/ Separation lamp (AR-501/505 only)
Fusing system	Heat roller
Fusing cleaning	Yes (AR-501/505 only)

16. Outlook

	W x D x H (mm)	Machine occupying dimensions	Weight
AR-250	600 × 695 × 658	1292 × 630	About 81 kg
AR-280	600 × 695 × 698	1292 × 695	About 89 kg
AR-281	600 × 695 × 735	1292 × 695	About 87 kg
AR-285/335	600 × 695 × 750	1292 × 695	About 98 kg
AR-286/336	600 × 695 × 718	1292 × 695	About 101 kg
AR-405	600 × 700 × 750	1292 × 700	About 98 kg
AR-501/505	600 × 700 × 773	1292 × 700	About 102 kg

17. Power supply

Voltage	100 V, 110 V, 120 V, 127 V, 220-230 V, 240 V
Frequency	50/60 Hz Common

18. Power consumption

	AR-280/285/335	AR-250/281/286/336/405	AR-501/505
Max. power consumption	Less than 1440 W	Less than 1440 W	Less than 1590 W

19. Environmental measures

A. EnergyStar

	AR-250	AR-280/285	AR-281/286	AR-335	AR-336	AR-405	AR-501/505	
Low power mode (Pre-heat mode)	Less than 101.25 W	Less than 112.8 W	Less than 112.8 W	Less than 132.05 W	Less than 132.05 W	Less than 159 W	Less than 197.5 W	
	Recovery time	Less than 30 sec						Less than 1 min
Sleep mode (Power save mode)	Power consumption	Less than 15 W	Less than 15 W	Less than 15 W	Less than 15 W	Less than 15 W	Less than 20 W	
	Shift time	Max. 240 min (Default 60 min)						Max. 240 min (Default 90 min)

20. Combination of functions

AR-280/285/335

	Independent zooming	AMS	Water mark	Stamp	Page print	Date print	Black-white reversion	Centering	Edge erase	Binding margin	1-set 2-copy (Document table only)	Middle binding	Repeat	Multi shot (DF only)	OHP insert paper	Cover insertion (DF only)	Hi-Fi copy	Duplex copy direction switch	Offset	Group	Sort	Staple sort	
S → S	○	○	○	○	○	○	○	○	○	○	○	▲	○	○	○	○	○	○	○	○	○	○	○
S (Even number) → D	○	○	○	○	○	○	○	○	○	○	○	▲	○	○	○	○	○	○	○	○	○	○	○
S (Odd number) → D (DF only)	○	○	○	○	○	○	○	○	○	○	○	▲	○	○	○	○	○	○	○	○	○	○	○
S → D (Auto)	○	○	○	○	○	○	○	○	○	○	○	▲	○	○	○	○	○	○	○	○	○	○	○
D → D (DF only)	○	○	○	○	○	○	○	○	○	○	○	▲	○	○	○	○	○	○	○	○	○	○	○
D → S (DF only)	○	○	○	○	○	○	○	○	○	○	○	▲	○	○	○	○	○	○	○	○	○	○	○
Staple sort	○	○	○	○	○	○	○	○	○	○	○	○	○	○	○	○	○	○	○	○	○	○	○
Sort	○	○	○	○	○	○	○	○	○	○	○	○	○	○	○	○	○	○	○	○	○	○	○
Group	○	○	○	○	○	○	○	○	○	○	○	○	○	○	○	○	○	○	○	○	○	○	○
Offset	○	○	○	○	○	○	○	○	○	○	○	○	○	○	○	○	○	○	○	○	○	○	○
Duplex copy direction switch	○	○	○	○	○	○	○	○	○	○	○	○	○	○	○	○	○	○	○	○	○	○	○
Hi-Fi copy (*)	○	○	○	○	○	○	○	○	○	○	○	○	○	○	○	○	○	○	○	○	○	○	○
Cover insertion (DF only)	○	○	○	○	○	○	○	○	○	○	○	○	○	○	○	○	○	○	○	○	○	○	○
OHP insert paper	○	○	○	○	○	○	○	○	○	○	○	○	○	○	○	○	○	○	○	○	○	○	○
Multi shot (DF only)	○	○	○	○	○	○	○	○	○	○	○	○	○	○	○	○	○	○	○	○	○	○	○
Repeat	○	○	○	○	○	○	○	○	○	○	○	○	○	○	○	○	○	○	○	○	○	○	○
Middle binding	○	○	○	○	○	○	○	○	○	○	○	○	○	○	○	○	○	○	○	○	○	○	○
1-set 2-copy (Document table only)	○	○	○	○	○	○	○	○	○	○	○	○	○	○	○	○	○	○	○	○	○	○	○
Binding margin	○	○	○	○	○	○	○	○	○	○	○	○	○	○	○	○	○	○	○	○	○	○	○
Edge erase	○	○	○	○	○	○	○	○	○	○	○	○	○	○	○	○	○	○	○	○	○	○	○
Centering	○	○	○	○	○	○	○	○	○	○	○	○	○	○	○	○	○	○	○	○	○	○	○
Black-white reversion	○	○	○	○	○	○	○	○	○	○	○	○	○	○	○	○	○	○	○	○	○	○	○
Date print	○	○	○	○	○	○	○	○	○	○	○	○	○	○	○	○	○	○	○	○	○	○	○
Page print	○	○	○	○	○	○	○	○	○	○	○	○	○	○	○	○	○	○	○	○	○	○	○
Stamp	○	○	○	○	○	○	○	○	○	○	○	○	○	○	○	○	○	○	○	○	○	○	○
Water mark	○	○	○	○	○	○	○	○	○	○	○	○	○	○	○	○	○	○	○	○	○	○	○
AMS	○	○	○	○	○	○	○	○	○	○	○	○	○	○	○	○	○	○	○	○	○	○	○

▲ Follows the setting on the middle binding display.

△ Only one set of copies available.

* Combination with SPF mode is inhibited.

AR-250/281/286/336/405/501/505

	Independent zooming	AMS	Water mark	Stamp	Page print	Date print	Black-white reversion	Centering	Edge erase	Binding margin	1-set 2-copy (Document table only)	Middle binding	Repeat	Multi shot	OHP insert paper	Cover insertion (DF only)	Duplex copy direction switch	Offset	Group	Sort	Staple sort
S → S	○	○	○	○	○	○	○	○	○	○	○	▲	○	○	○	○	X	○	○	○	○
S → D (Auto)	○	○	○	○	○	○	○	○	○	○	○	▲	○	○	X	○	○	○	○	○	○
D → D (DF only)	○	○	○	○	○	○	○	○	○	○	X	▲	○	○	X	○	X	○	○	○	○
D → S (DF only)	○	○	○	○	○	○	○	○	○	○	X	▲	○	○	○	○	X	○	○	○	○
Staple sort	○	○	○	○	○	○	○	○	○	○	○	X	○	○	X	○	○	○	X	X	
Sort	○	○	○	○	○	○	○	○	○	○	○	○	○	○	△	○	○		X		
Group	○	○	○	○	○	○	○	○	○	○	○	○	○	○	△	○	○				
Offset	○	○	○	○	○	○	○	○	○	○	○	○	○	○	○	○	○				
Duplex copy direction switch	○	○	○	○	○	○	○	○	○	○	X	○	X	X	X	○					
Cover insertion (DF only)	○	○	○	○	○	○	X	○	○	○	X	X	X	X	X						
OHP insert paper	○	○	○	○	○	○	X	○	○	○	○	X	X	X							
Multi shot (DF only)	X	X	○	○	○	○	X	○	○	○	X	X	X								
Repeat	○	X	○	○	○	○	○	○	○	○	X	X									
Middle binding	X	○	○	○	○	○	X	○	○	○	X										
1-set 2-copy (Document table only)	○	○	○	○	○	○	X	○	○	○											
Binding margin	○	○	○	○	○	○	○	○	○												
Edge erase	○	○	○	○	○	○	○														
Centering	○	○	○	○	○	○															
Black-white reversion	○	○	X	○	○	○															
Date print	○	○	○	○	○																
Page print	○	○	○	○																	
Stamp	○	○	X																		
Water mark	○	○																			
AMS	○																				

▲ Follows the setting on the middle binding display.

△ Only one set of copies available.

[3] CONSUMABLE PARTS

1. Consumable Parts List

A. USA

AR-250/280/281/285/286/335/336

No.	ITEM	CONTENTS	LIFE	MODEL NAME		REMARKS
				AR-280/285/ 335	AR-250/281/ 286/336	
1	Drum	OPC Drum ×1	160K	AR-330DR	AR-336DR	
2	Developer (Black)	Developer (800g) ×10	80K (×10)	AR-330MD (AR-330ND)	AR-336MD (AR-336ND)	AR-330MD = (AR-330ND) × 10 AR-336MD = (AR-336ND) × 10
3	Toner (Black)	Toner Cartridge (700g) ×10	17.5K (×10)	AR-330MT (AR-330NT)	AR-400MT (AR-400NT)	AR-330MT = (AR-330NT) × 10 AR-400MT = (AR-400NT) × 10
4	Upper Heat Roller Kit	Upper Heat Roller ×1 Fusing Separation Pawl (upper) ×4 Heat Roller Gear ×1	160K	AR-330UH		Replacement of fusing separation pawl for every 80 K should be done using those supplied separately.
5	Lower Heat Roller Kit	Lower Heat Roller ×1 Fusing Separation Pawl (lower) ×2	160K	AR-330LH		Replacement of fusing separation pawl for every 80 K should be done using those supplied separately.
6	80K Maintenance Kit	Cleaner Blade ×1 Charging Plate Unit ×1 Drum Separation Unit ×1	80K	AR-330KA1	AR-400KA	
7	Cleaner Blade	Cleaner Blade ×10	80K (×10)	AR-330CB		AR-330CB= (AR-330BL) ×10
8	Staple Cartridge	Staple Cartridge (SF-SC11) ×3	5K staples ×3	SF-SC11		Cartridge for AR-FN1 Common with S55,S55 N
9	Staple Cartridge	Staple Cartridge (SF-SC12) ×3	5K staples ×3	SF-LS12		Cartridge for AR-FN2 Common with S54 SF-LS12= (SF-SC12) ×3
9	Upper Heat Roller	Upper Heat Roller ×1	160K	AR-330HU		
10	Fusing Separation Pawl (upper)	Fusing Separation Pawl (upper) ×4 ×10	80K (×10)	SF-216UP		SF216UP=SF-216TP (incl.4 pawls) ×10
11	Heat Roller Gear	Heat Roller Gear ×10	160K (×10)	SF-216HG		SF216HG= (SF216JG) ×10
12	Lower Heat Roller	Lower Heat Roller ×1	160K	AR-330HR		
13	Fusing Separation Pawl (lower)	Fusing Separation Pawl (lower) ×2 ×10	80K (×10)	SF-240LP		SF240LP=SF-240MP (incl.2 pawls) ×10
14	Drum Separation Pawl	Drum Separation Pawl ×2 ×10	80K (×10)	SF-240DP		SF240DP=SF-240EP (incl.2 pawls) ×10
15	Screen Grid	Screen Grid ×10	80K (×10)	AR-330SU		AR-330SU= (AR-330TU) ×10
16	Charging Plate	Charging Plate ×10	80K (×10)	AR-330PU		AR-330PU= (AR-330NU) ×10
17	Waste Toner Bottle	Waste Toner Bottle ×1		AR-330TB		
18	Busing	Busing ×2 ×10	160K (×10)	SF-240BU		SF-240BU= (SF-240DU) ×10
19	Ozone Filter	Ozone Filter ×10	80K (×10)	AR-330FL		AR-330FL= (AR-330JL) ×10
20	Copy Lamp	Copy Lamp ×10		AR-330CL		AR-330CL= (AR-330DL) ×10
21	MC Unit	MC Unit ×10		AR-330MC		AR-330MC= (AR-330NC) ×10

Note: Maintenance parts other than mentioned above must be ordered through the parts department using the proper part number.

AR-405

No.	ITEM	CONTENTS	LIFE	MODEL NAME	REMARKS	
1	Drum	OPC Drum ×1	180K	AR-400DR		
2	Developer (Black)	Developer (800g) ×10	90K (×10)	AR-400MD	AR-400MD = (AR-400ND) × 10	
3	Toner (Black)	Toner Cartridge (700g) ×10	22K (×1)	AR-400MT	AR-400MT = (AR-400NT) × 10	
4	Upper Heat Roller Kit	Upper Heat Roller ×1 Fusing Separation Pawl (upper) ×4 Heat Roller Gear ×1	180K	AR-330UH		Replacement of fusing separation pawl for every 80 K should be done using those supplied separately.
5	Lower Heat Roller Kit	Lower Heat Roller ×1 Fusing Separation Pawl (lower) ×2	180K	AR-330LH		Replacement of fusing separation pawl for every 80 K should be done using those supplied separately.
6	90K Maintenance Kit	Cleaner Blade ×1 Charging Plate Unit ×1 Drum Separation Unit ×1	90K	AR-400KA1		
7	Cleaner Blade	Cleaner Blade ×10	90K (×10)	AR-330CB		AR-330CB= (AR-330BL) ×10
8	Staple Cartridge	Staple Cartridge (SF-SC11) ×3	5K staples ×3	SF-SC11		Cartridge for AR-FN1 Common with S55,S55 N
9	Staple Cartridge	Staple Cartridge (SF-SC12) ×3	5K staples ×3	SF-LS12		Cartridge for AR-FN2 Common with S54 SF-LS12= (SF-SC12) ×3
9	Upper Heat Roller	Upper Heat Roller ×1	180K	AR-330HU		
10	Fusing Separation Pawl (upper)	Fusing Separation Pawl (upper) ×4 ×10	90K (×10)	SF-216UP		SF216UP=SF-216TP (incl.4 pawls) ×10
11	Heat Roller Gear	Heat Roller Gear ×10	180K (×10)	SF-216HG		SF216HG= (SF216JG) ×10
12	Lower Heat Roller	Lower Heat Roller ×1	180K	AR-330HR		
13	Fusing Separation Pawl (lower)	Fusing Separation Pawl (lower) ×2 ×10	90K (×10)	SF-240LP		SF240LP=SF-240MP (incl.2 pawls) ×10
14	Drum Separation Pawl	Drum Separation Pawl ×2 ×10	90K (×10)	SF-240DP		SF240DP=SF-240EP (incl.2 pawls) ×10
15	Screen Grid	Screen Grid ×10	90K (×10)	AR-330SU		AR-330SU= (AR-330TU) ×10
16	Charging Plate	Charging Plate ×10	90K (×10)	AR-330PU		AR-330PU= (AR-330NU) ×10
17	Waste Toner Bottle	Waste Toner Bottle ×1		AR-330TB		
18	Busing	Busing ×2 ×10	180K (×10)	SF-240BU		SF-240BU= (SF-240DU) ×10
19	Ozone Filter	Ozone Filter ×10	90K (×10)	AR-330FL		AR-330FL= (AR-330JL) ×10
20	Copy Lamp	Copy Lamp ×10		AR-330CL		AR-330CL= (AR-330DL) ×10
21	MC Unit	MC Unit ×10		AR-330MC		AR-330MC= (AR-330NC) ×10

Note: Maintenance parts other than mentioned above must be ordered through the parts department using the proper part number.

AR-501/505

No.	ITEM	CONTENTS	LIFE	MODEL NAME	REMARKS	
1	Drum	OPC Drum	×1 250K	AR-500DR		
2	Developer (Black)	Developer (800g)	×10 250K (×10)	AR-500MD (AR500ND)	(AR-500ND) ×10 = AR-500MD	
3	Toner (Black)	Toner Cartridge (700g)	×10 25K (×10)	AR-500MT (AR-500NT)	(AR-500NT) ×10 = AR-500MT	
4	Upper Heat Roller Kit	Upper Heat Roller Fusing Separation Pawl (upper) Heat Roller Gear	×1 ×4 ×1	250K	AR-505UH	
5	Lower Heat Roller Kit	Lower Heat Roller Fusing Separation Pawl (lower)	×1 ×2	250K	AR-505LH	
6	125K Maintenance Kit	Cleaner Blade Charging Plate Unit Drum Separation Unit Upper CL Roller Unit	×1 ×1 ×1 ×1	125K	AR-505KA1	
7	Cleaner Blade	Cleaner Blade	×10	125K (×10)	AR-330CB	AR-330CB= (AR-330BL) ×10
8	Curly Adjustment Roller	Curly Adjustment Roller	×10	250K (×10)	AR-505KR	AR-505KR= (AR-505JR) ×10
9	Staple Cartridge	Staple Cartridge (SF-SC11)	×3 5K staples ×3	SF-SC11	Cartridge for AR-FN1/FN1N/FN3 Common with S55,S55 N	
10	Upper Heat Roller	Upper Heat Roller	×1 250K	AR-505HU		
11	Fusing Separation Pawl (upper)	Fusing Separation Pawl (upper) ×4	×10 125K (×10)	AR-505UP	AR-505UP=AR-505TP (incl.4 pawls) ×10	
12	Heat Roller Gear	Heat Roller Gear	×10 250K (×10)	SF-216HG	SF216HG= (SF216JG) ×10	
13	Lower Heat Roller	Lower Heat Roller	×1 250K	AR-505HR		
14	Fusing Separation Pawl (lower)	Fusing Separation Pawl (lower) ×2	×10 125K (×10)	SF-240LP	SF240LP=SF-240MP (incl.2 pawls) ×10	
15	Drum Separation Pawl	Drum Separation Pawl ×2	×10 125K (×10)	AR-505DP	AR-505DP=AR-505EP (incl.2 pawls) ×10	
16	Screen Grid	Screen Grid	×10 125K (×10)	AR-330SU	AR-330SU= (AR-330TU) ×10	
17	Charging Plate	Charging Plate	×10 125K (×10)	AR-330PU	AR-330PU= (AR-330NU) ×10	
18	Waste Toner Bottle	Waste Toner Bottle	×1	AR-330TB		
19	Busing	Busing ×2	×10 250K (×10)	SF-240BU	SF-240BU= (SF-240DU) ×10	
20	Ozone Filter	Ozone Filter	×10 125K (×10)	AR-330FL	AR-330FL= (AR-330JL) ×10	
21	Ozone Filter 50	Ozone Filter 50	×10 125K (×10)	AR-505FL	AR-505FL= (AR-505JL) ×10	
22	MC Unit	MC Unit	×10	AR-330MC	AR-330MC= (AR-330NC) ×10	

Note: Maintenance parts other than mentioned above must be ordered through the parts department using the proper part number.

B. Canada

AR-250/280/281/285/286/335/336

No.	ITEM	CONTENTS	LIFE	MODEL NAME		REMARKS
				AR-280/285/ 335	AR-250/281/ 286/336	
1	Drum	OPC Drum	×1 160K	AR-330DR	AR-336DR	
2	Developer (Black)	Developer (800g)	×10 80K (×10)	AR-330MD (AR330ND)	AR-336MD (AR-336ND)	AR-330MD = (AR-330ND) × 10 AR-336MD = (AR-336ND) × 10
3	Toner (Black)	Toner Cartridge (700g)	×10 17.5K (×10)	AR-330MT (AR-330NT)	AR-400MT (AR-400NT)	AR-330MT = (AR-330NT) × 10 AR-400MT = (AR-400NT) × 10
4	80K PM Kit	Cleaner Blade Charging Plate Unit Waste Toner Bottle Fusing Separation Pawl (upper) Fusing Separation Pawl (lower) Screen Grid Drum Separation Unit	×1 ×1 ×3 ×4 ×2 ×1 ×1	80K	AR-330KA	AR-400KA
5	160K PM Kit	Upper Heat Roller Lower Heat Roller Toner Receiving Seal DV Seal Heat Roller Gear	×1 ×1 ×1 ×1 ×1	160K	AR-330KB	
6	Staple Cartridge	Staple Cartridge (SF-SC11)	×3 5K staples ×3	SF-SC11		Cartridge for AR-FN1 Common with S55,S55 N
7	Staple Cartridge	Staple Cartridge (SF-SC12)	×3 5K staples ×3	SF-LS12		Cartridge for AR-FN2 Common with S54 SF-LS12= (SF-SC12) ×3
8	Cleaner Blade	Cleaner Blade	×10 80K (×10)	AR-330CB		AR-330CB= (AR-330BL) ×10
9	Upper Heat Roller	Upper Heat Roller	×1 160K	AR-330HU		
10	Fusing Separation Pawl (upper)	Fusing Separation Pawl (upper) ×4	×10 80K (×10)	SF-216UP		SF216UP=SF-216TP (incl.4 pawls) ×10
11	Heat Roller Gear	Heat Roller Gear	×10 160K (×10)	SF-216HG		SF216HG= (SF216JG) ×10
12	Lower Heat Roller	Lower Heat Roller	×1 160K	AR-330HR		
13	Fusing Separation Pawl (lower)	Fusing Separation Pawl (lower) ×2	×10 80K (×10)	SF-240LP		SF240LP=SF-240MP (incl.2 pawls) ×10
14	Drum Separation Pawl	Drum Separation Pawl ×2	×10 80K (×10)	SF-240DP		SF240DP=SF-240EP (incl.2 pawls) ×10
15	Screen Grid	Screen Grid	×10 80K (×10)	AR-330SU		AR-330SU= (AR-330TU) ×10
16	Charging Plate	Charging Plate	×10 80K (×10)	AR-330PU		AR-330PU= (AR-330NU) ×10
17	Waste Toner Bottle	Waste Toner Bottle	×1	AR-330TB		
18	Busing	Busing ×2	×10 160K (×10)	SF-240BU		SF-240BU= (SF-240DU) ×10
19	Ozone Filter	Ozone Filter	×10 80K (×10)	AR-330FL		AR-330FL= (AR-330JL) ×10
20	Copy Lamp	Copy Lamp	×10	AR-330CL		AR-330CL= (AR-330DL) ×10
21	MC Unit	MC Unit	×10	AR-330MC		AR-330MC= (AR-330NC) ×10

Note: Maintenance parts other than mentioned above must be ordered through the parts department using the proper part number.

AR-405

No.	ITEM	CONTENTS	LIFE	MODEL NAME	REMARKS
1	Drum	OPC Drum x1	180K	AR-400DR	
2	Developer (Black)	Developer (800g) x10	80K (x10)	AR-400MD	AR-400MD = (AR-400ND) x 10
3	Toner (Black)	Toner Cartridge (700g) x10	22K (x1)	AR-400MT	AR-400MT = (AR-400NT) x 10
4	90K PM Kit	Cleaner Blade x1 Charging Plate Unit x1 Waste Toner Bottle x3 Fusing Separation Pawl (upper) x4 Fusing Separation Pawl (lower) x2 Screen Grid x1 Drum Separation Unit x1	90K	AR-400KA	
5	180K PM Kit	Upper Heat Roller x1 Lower Heat Roller x1 Toner Receiving Seal x1 DV Seal x1 Heat Roller Gear x1	180K	AR-330KB	
6	Staple Cartridge	Staple Cartridge (SF-SC11) x3	5K staples x3	SF-SC11	Cartridge for AR-FN1 Common with S55,S55 N
7	Staple Cartridge	Staple Cartridge (SF-SC12) x3	5K staples x3	SF-LS12	Cartridge for AR-FN2 Common with S54 SF-LS12= (SF-SC12) x3
8	Cleaner Blade	Cleaner Blade x10	90K (x10)	AR-330CB	AR-330CB= (AR-330BL) x10
9	Upper Heat Roller	Upper Heat Roller x1	180K	AR-330HU	
10	Fusing Separation Pawl (upper)	Fusing Separation Pawl (upper) x4	90K (x10)	SF-216UP	SF216UP=SF-216TP (incl.4 pawls) x10
11	Heat Roller Gear	Heat Roller Gear x10	180K (x10)	SF-216HG	SF216HG= (SF216JG) x10
12	Lower Heat Roller	Lower Heat Roller x1	180K	AR-330HR	
13	Fusing Separation Pawl (lower)	Fusing Separation Pawl (lower) x2	90K (x10)	SF-240LP	SF240LP=SF-240MP (incl.2 pawls) x10
14	Drum Separation Pawl	Drum Separation Pawl x2	90K (x10)	SF-240DP	SF240DP=SF-240EP (incl.2 pawls) x10
15	Screen Grid	Screen Grid x10	90K (x10)	AR-330SU	AR-330SU= (AR-330TU) x10
16	Charging Plate	Charging Plate x10	90K (x10)	AR-330PU	AR-330PU= (AR-330NU) x10
17	Waste Toner Bottle	Waste Toner Bottle x1		AR-330TB	
18	Busing	Busing x2	180K (x10)	SF-240BU	SF-240BU= (SF-240DU) x10
19	Ozone Filter	Ozone Filter x10	90K (x10)	AR-330FL	AR-330FL= (AR-330JL) x10
20	Copy Lamp	Copy Lamp x10		AR-330CL	AR-330CL= (AR-330DL) x10
21	MC Unit	MC Unit x10		AR-330MC	AR-330MC= (AR-330NC) x10

Note: Maintenance parts other than mentioned above must be ordered through the parts department using the proper part number.

AR-505

No.	ITEM	CONTENTS	LIFE	MODEL NAME	REMARKS
1	Drum	OPC Drum x1	250K	AR-500DR	
2	Developer (Black)	Developer (800g) x10	250K (x10)	AR-500MD (AR500ND)	(AR-500ND) x10 = AR-500MD
3	Toner (Black)	Toner Cartridge (700g) x10	25K (x10)	AR-500MT (AR-500NT)	(AR-500NT) x10 = AR-500MT
4	125K PM Kit	Cleaner Blade x1 Charging Plate Unit x1 Waste Toner Bottle x3 Fusing Separation Pawl (upper) x4 Fusing Separation Pawl (lower) x2 Screen Grid x1 Drum Separation Unit x1 Cleaning Roller x1 Upper CL Roller Unit x1	125K	AR-505KA	
5	250K PM Kit	Upper Heat Roller x1 Lower Heat Roller x1 Toner Receiving Seal x1 DV Seal x1 Heat Roller Gear x1 Curl Adjustment Roller x1	250K	AR-505KB	
6	Staple Cartridge	Staple Cartridge (SF-SC11) x3	5K staples x3	SF-SC11	Cartridge for AR-FN1/FN1N/FN3 Common with S55,S55 N
7	Cleaner Blade	Cleaner Blade x10	125K (x10)	AR-330CB	AR-330CB= (AR-330BL) x10
8	Upper Heat Roller	Upper Heat Roller x1	250K	AR-505HU	
9	Fusing Separation Pawl (upper)	Fusing Separation Pawl (upper) x4	125K (x10)	AR-505UP	AR-505UP=AR-505TP (incl.4 pawls) x10
10	Heat Roller Gear	Heat Roller Gear x10	250K (x10)	SF-216HG	SF216HG= (SF216JG) x10
11	Lower Heat Roller	Lower Heat Roller x1	250K	AR-505HR	
12	Fusing Separation Pawl (lower)	Fusing Separation Pawl (lower) x2	125K (x10)	SF-240LP	SF240LP=SF-240MP (incl.2 pawls) x10
13	Drum Separation Pawl	Drum Separation Pawl x2	125K (x10)	AR-505DP	AR-505DP=AR-505EP (incl.2 pawls) x10
14	Screen Grid	Screen Grid x10	125K (x10)	AR-330SU	AR-330SU= (AR-330TU) x10
15	Charging Plate	Charging Plate x10	125K (x10)	AR-330PU	AR-330PU= (AR-330NU) x10
16	Waste Toner Bottle	Waste Toner Bottle x1		AR-330TB	
17	Busing	Busing x2	250K (x10)	SF-240BU	SF-240BU= (SF-240DU) x10
18	Ozone Filter	Ozone Filter x10	125K (x10)	AR-330FL	AR-330FL= (AR-330JL) x10
19	Ozone Filter 50	Ozone Filter 50 x10	125K (x10)	AR-505FL	AR-505FL= (AR-505JL) x10
20	MC Unit	MC Unit x10		AR-330MC	AR-330MC= (AR-330NC) x10
21	Curl Adjustment Roller	Curl Adjustment Roller x10	250K (x10)	AR-505KR	AR-505KR= (AR-505JR) x10

Note: Maintenance parts other than mentioned above must be ordered through the parts department using the proper part number.

C. Europe / U.K. / Australia / New Zealand

AR-250/280/281/285/286/335/336

No.	ITEM	CONTENTS	LIFE	MODEL NAME		REMARKS
				AR-280/285/ 335	AR-250/281/ 286/336	
1	Drum	OPC Drum x1	160K	AR-330DM	AR-331DM	
2	Developer (Black)	Developer (800g) x10	80K (x10)	AR-330LD (AR330DV)	AR-336LD (AR-336DV)	AR-330LD = (AR-330DV) x 10 AR-336LD = (AR-336DV) x 10
3	Toner (Black)	Toner Cartridge (700g) x10	17.5K (x10)	AR-330LT (AR-330T)	AR-400LT (AR-400T)	AR-330LT = (AR-330T) x 10 AR-400LT = (AR-400T) x 10
4	80K PM Kit	Cleaner Blade x1 Charging Plate Unit x1 Waste Toner Bottle x3 Fusing Separation Pawl (upper) x4 Fusing Separation Pawl (lower) x2 Screen Grid x1 Drum Separation Unit x1	80K	AR-330KA	AR-400KA	
5	160K PM Kit	Upper Heat Roller x1 Lower Heat Roller x1 Toner Receiving Seal x1 DV Seal x1 Heat Roller Gear x1	160K	AR-330KB		
6	Staple Cartridge	Staple Cartridge (SF-SC11) x3	5K staples x3	SF-SC11		Cartridge for AR-FN1 Common with S55,S55 N
7	Staple Cartridge	Staple Cartridge (SF-SC12) x3	5K staples x3	SF-LS12		Cartridge for AR-FN2 Common with S54 SF-LS12= (SF-SC12) x3
8	Cleaner Blade	Cleaner Blade x10	80K (x10)	AR-330CB		AR-330CB= (AR-330BL) x10
9	Upper Heat Roller	Upper Heat Roller x1	160K	AR-330HU		
10	Fusing Separation Pawl (upper)	Fusing Separation Pawl (upper) x4 x10	80K (x10)	SF-216UP		SF216UP=SF-216TP (incl.4 pawls) x10
11	Heat Roller Gear	Heat Roller Gear x10	160K (x10)	SF-216HG		SF216HG= (SF216JG) x10
12	Lower Heat Roller	Lower Heat Roller x1	160K	AR-330HR		
13	Fusing Separation Pawl (upper)	Fusing Separation Pawl (lower) x2 x10	80K (x10)	SF-240LP		SF240LP=SF-240MP (incl.2 pawls) x10
14	Drum Separation Pawl	Drum Separation Pawl x2 x10	80K (x10)	SF-240DP		SF240DP=SF-240EP (incl.2 pawls) x10
15	Screen Grid	Screen Grid x10	80K (x10)	AR-330SU		AR-330SU= (AR-330TU) x10
16	Charging Plate	Charging Plate x10	80K (x10)	AR-330PU		AR-330PU= (AR-330NU) x10
17	Waste Toner Bottle	Waste Toner Bottle x1		AR-330TB		
18	Busing	Busing x2 x10	160K (x10)	SF-240BU		SF-240BU= (SF-240DU) x10
19	Ozone Filter	Ozone Filter x10	80K (x10)	AR-330FL		AR-330FL= (AR-330JL) x10
20	Copy Lamp	Copy Lamp x10		AR-330CL		AR-330CL= (AR-330DL) x10
21	MC Unit	MC Unit x10		AR-330MC		AR-330MC= (AR-330NC) x10

Note: Maintenance parts other than mentioned above must be ordered through the parts department using the proper part number.

AR-405

No.	ITEM	CONTENTS	LIFE	MODEL NAME	REMARKS	
1	Drum	OPC Drum x1	180K	AR-400DM		
2	Developer (Black)	Developer (800g) x10	90K (x10)	AR-400LD	AR-400LD = (AR-400DV) x 10	
3	Toner (Black)	Toner Cartridge (700g) x10	22K (x1)	AR-400LT	AR-400LT = (AR-400T) x 10	
4	90K PM Kit	Cleaner Blade x1 Charging Plate Unit x1 Waste Toner Bottle x3 Fusing Separation Pawl (upper) x4 Fusing Separation Pawl (lower) x2 Screen Grid x1 Drum Separation Unit x1	90K	AR-400KA		
5	180K PM Kit	Upper Heat Roller x1 Lower Heat Roller x1 Toner Receiving Seal x1 DV Seal x1 Heat Roller Gear x1	180K	AR-400KB		
6	Staple Cartridge	Staple Cartridge (SF-SC11) x3	5K staples x3	SF-SC11		Cartridge for AR-FN1 Common with S55,S55 N
7	Staple Cartridge	Staple Cartridge (SF-SC12) x3	5K staples x3	SF-LS12		Cartridge for AR-FN2 Common with S54 SF-LS12= (SF-SC12) x3
8	Cleaner Blade	Cleaner Blade x10	90K (x10)	AR-330CB		AR-330CB= (AR-330BL) x10
9	Upper Heat Roller	Upper Heat Roller x1	180K	AR-400HU		
10	Fusing Separation Pawl (upper)	Fusing Separation Pawl (upper) x4 x10	90K (x10)	SF-216UP		SF216UP=SF-216TP (incl.4 pawls) x10
11	Heat Roller Gear	Heat Roller Gear x10	180K (x10)	SF-216HG		SF216HG= (SF216JG) x10
12	Lower Heat Roller	Lower Heat Roller x1	180K	AR-330HR		
13	Fusing Separation Pawl (upper)	Fusing Separation Pawl (lower) x2 x10	90K (x10)	SF-240LP		SF240LP=SF-240MP (incl.2 pawls) x10
14	Drum Separation Pawl	Drum Separation Pawl x2 x10	90K (x10)	SF-240DP		SF240DP=SF-240EP (incl.2 pawls) x10
15	Screen Grid	Screen Grid x10	90K (x10)	AR-330SU		AR-330SU= (AR-330TU) x10
16	Charging Plate	Charging Plate x10	90K (x10)	AR-330PU		AR-330PU= (AR-330NU) x10
17	Waste Toner Bottle	Waste Toner Bottle x1		AR-330TB		
18	Busing	Busing x2 x10	180K (x10)	SF-240BU		SF-240BU= (SF-240DU) x10
19	Ozone Filter	Ozone Filter x10	90K (x10)	AR-330FL		AR-330FL= (AR-330JL) x10
20	Copy Lamp	Copy Lamp x10		AR-330CL		AR-330CL= (AR-330DL) x10
21	MC Unit	MC Unit x10		AR-330MC		AR-330MC= (AR-330NC) x10

Note: Maintenance parts other than mentioned above must be ordered through the parts department using the proper part number.

AR-505

No.	ITEM	CONTENTS	LIFE	MODEL NAME	REMARKS
1	125K PM Kit	Cleaner Blade ×1 Charging Plate Unit ×1 Waste Toner Bottle ×3 Fusing Separation Pawl (upper) ×4 Fusing Separation Pawl (lower) ×2 Screen Grid ×1 Drum Separation Unit ×1 Cleaning Roller ×1	125K	AR-505KA	
2	250K PM Kit	Upper Heat Roller ×1 Lower Heat Roller ×1 Toner Receiving Seal ×1 DV Seal ×1 Heat Roller Gear ×1 Curl Adjustment Roller ×1 Upper CL Roller Unit ×1	250K	AR-505KB	
3	Staple Cartridge	Staple Cartridge (SF-SC11) ×3	5K staples ×3	SF-SC11	Cartridge for AR-FN1/FN1N/FN3 Common with S55,S55 N
4	Cleaner Blade	Cleaner Blade ×10	125K (×10)	AR-330CB	AR-330CB= (AR-330BL) ×10
5	Upper Heat Roller	Upper Heat Roller ×1	250K	AR-505HU	
6	Fusing Separation Pawl (upper)	Fusing Separation Pawl (upper) ×4	125K (×10)	AR-505UP	AR-505UP=AR-505TP (incl.4 pawls) ×10
7	Heat Roller Gear	Heat Roller Gear ×10	250K (×10)	SF-216HG	SF216HG= (SF216JG) ×10
8	Lower Heat Roller	Lower Heat Roller ×1	250K	AR-505HR	
9	Fusing Separation Pawl (lower)	Fusing Separation Pawl (lower) ×2	125K (×10)	SF-240LP	SF240LP=SF-240MP (incl.2 pawls) ×10
10	Drum Separation Pawl	Drum Separation Pawl ×2	125K (×10)	AR-505DP	AR-505DP=AR-505EP (incl.2 pawls) ×10
11	Screen Grid	Screen Grid ×10	125K (×10)	AR-330SU	AR-330SU= (AR-330TU) ×10
12	Charging Plate	Charging Plate ×10	125K (×10)	AR-330PU	AR-330PU= (AR-330NU) ×10
13	Waste Toner Bottle	Waste Toner Bottle ×1		AR-330TB	
14	Busing	Busing ×2	250K (×10)	SF-240BU	SF-240BU= (SF-240DU) ×10
15	Ozone Filter	Ozone Filter ×10	125K (×10)	AR-330FL	AR-330FL= (AR-330JL) ×10
16	Ozone Filter 50	Ozone Filter 50 ×10	125K (×10)	AR-505FL	AR-505FL= (AR-505JL) ×10
17	MC Unit	MC Unit ×10		AR-330MC	AR-330MC= (AR-330NC) ×10
18	Curl Adjustment Roller	Curl Adjustment Roller ×10	250K (×10)	AR-505KR	AR-505KR= (AR-505JR) ×10

Note: Maintenance parts other than mentioned above must be ordered through the parts department using the proper part number.

D. Asia / Middle & South America

AR-250/280/281/285/286/335/336

No.	ITEM	CONTENTS	LIFE	MODEL NAME		REMARKS
				AR-280/285/ 335	AR-250/281/ 286/336	
1	Drum	OPC Drum ×1	160K	AR-330DR	AR-336DR	
2	Developer (Black)	Developer (800g) ×10	80K (×10)	AR-330CD (AR-330SD)	AR-336CD (AR-336SD)	AR-330CD = (AR-330SD) × 10 AR-336CD = (AR-336SD) × 10
3	Toner (Black)	Toner Cartridge (700g) ×10	17.5K (×10)	AR-330CT (AR-330ST)	AR-400CT (AR-400ST)	AR-330CT = (AR-330ST) × 10 AR-400CT = (AR-400ST) × 10
4	80K PM Kit	Cleaner Blade ×1 Charging Plate Unit ×1 Waste Toner Bottle ×3 Fusing Separation Pawl (upper) ×4 Fusing Separation Pawl (lower) ×2 Screen Grid ×1 Drum Separation Unit ×1	80K	AR-330KA		
5	160K PM Kit	Upper Heat Roller ×1 Lower Heat Roller ×1 Toner Receiving Seal ×1 DV Seal ×1 Heat Roller Gear ×1	160K	AR-330KB		
6	Staple Cartridge	Staple Cartridge (SF-SC11) ×3	5K staples ×3	SF-SC11		Cartridge for AR-FN1 Common with S55,S55 N
7	Staple Cartridge	Staple Cartridge (SF-SC12) ×3	5K staples ×3	SF-LS12		Cartridge for AR-FN2 Common with S54 SF-LS12= (SF-SC12) ×3
8	Cleaner Blade	Cleaner Blade ×10	80K (×10)	AR-330CB		AR-330CB= (AR-330BL) ×10
9	Upper Heat Roller	Upper Heat Roller ×1	160K	AR-330HU		
10	Fusing Separation Pawl (upper)	Fusing Separation Pawl (upper) ×4	80K (×10)	SF-216UP		SF216UP=SF-216TP (incl.4 pawls) ×10
11	Heat Roller Gear	Heat Roller Gear ×10	160K (×10)	SF-216HG		SF216HG= (SF216JG) ×10
12	Lower Heat Roller	Lower Heat Roller ×1	160K	AR-330HR		
13	Fusing Separation Pawl (lower)	Fusing Separation Pawl (lower) ×2	80K (×10)	SF-240LP		SF240LP=SF-240MP (incl.2 pawls) ×10
14	Drum Separation Pawl	Drum Separation Pawl ×2	80K (×10)	SF-240DP		SF240DP=SF-240EP (incl.2 pawls) ×10
15	Screen Grid	Screen Grid ×10	80K (×10)	AR-330SU		AR-330SU= (AR-330TU) ×10
16	Charging Plate	Charging Plate ×10	80K (×10)	AR-330PU		AR-330PU= (AR-330NU) ×10
17	Waste Toner Bottle	Waste Toner Bottle ×1		AR-330TB		
18	Busing	Busing ×2	160K (×10)	SF-240BU		SF-240BU= (SF-240DU) ×10
19	Ozone Filter	Ozone Filter ×10	80K (×10)	AR-330FL		AR-330FL= (AR-330JL) ×10
20	Copy Lamp	Copy Lamp ×10		AR-330CL		AR-330CL= (AR-330DL) ×10
21	MC Unit	MC Unit ×10		AR-330MC		AR-330MC= (AR-330NC) ×10

Note: Maintenance parts other than mentioned above must be ordered through the parts department using the proper part number.

AR-405

No.	ITEM	CONTENTS	LIFE	MODEL NAME	REMARKS	
1	Drum	OPC Drum	×1	180K	AR-400DM	
2	Developer (Black)	Developer (800g)	×10	90K (×10)	AR-400CD	AR-400CD = (AR-400SD) × 10
3	Toner (Black)	Toner Cartridge (700g)	×10	22K (×1)	AR-400CT	AR-400CT = (AR-400ST) × 10
4	90K PM Kit	Cleaner Blade Charging Plate Unit Waste Toner Bottle Fusing Separation Pawl (upper) Fusing Separation Pawl (lower) Screen Grid Drum Separation Unit	×1 ×1 ×3 ×4 ×2 ×1 ×1	90K	AR-400KA	
5	180K PM Kit	Upper Heat Roller Lower Heat Roller Toner Receiving Seal DV Seal Heat Roller Gear	×1 ×1 ×1 ×1 ×1	180K	AR-400KB	
6	Staple Cartridge	Staple Cartridge (SF-SC11)	×3	5K staples ×3	SF-SC11	Cartridge for AR-FN1 Common with S55,S55 N
7	Staple Cartridge	Staple Cartridge (SF-SC12)	×3	5K staples ×3	SF-LS12	Cartridge for AR-FN2 Common with S54 SF-LS12= (SF-SC12) ×3
8	Cleaner Blade	Cleaner Blade	×10	90K (×10)	AR-330CB	AR-330CB= (AR-330BL) ×10
9	Upper Heat Roller	Upper Heat Roller	×1	180K	AR-400HU	
10	Fusing Separation Pawl (upper)	Fusing Separation Pawl (upper) ×4	×10	90K (×10)	SF-216UP	SF216UP=Sf-216TP (incl.4 pawls) ×10
11	Heat Roller Gear	Heat Roller Gear	×10	180K (×10)	SF-216HG	SF216HG= (SF216JG) ×10
12	Lower Heat Roller	Lower Heat Roller	×1	180K	AR-330HR	
13	Fusing Separation Pawl (lower)	Fusing Separation Pawl (lower) ×2	×10	90K (×10)	SF-240LP	SF240LP=Sf-240MP (incl.2 pawls) ×10
14	Drum Separation Pawl	Drum Separation Pawl ×2	×10	90K (×10)	SF-240DP	SF240DP=Sf-240EP (incl.2 pawls) ×10
15	Screen Grid	Screen Grid	×10	90K (×10)	AR-330SU	AR-330SU= (AR-330TU) ×10
16	Charging Plate	Charging Plate	×10	90K (×10)	AR-330PU	AR-330PU= (AR-330NU) ×10
17	Waste Toner Bottle	Waste Toner Bottle	×1		AR-330TB	
18	Busing	Busing ×2	×10	180K (×10)	SF-240BU	SF-240BU= (SF-240DU) ×10
19	Ozone Filter	Ozone Filter	×10	90K (×10)	AR-330FL	AR-330FL= (AR-330JL) ×10
20	Copy Lamp	Copy Lamp	×10		AR-330CL	AR-330CL= (AR-330DL) ×10
21	MC Unit	MC Unit	×10		AR-330MC	AR-330MC= (AR-330NC) ×10

Note: Maintenance parts other than mentioned above must be ordered through the parts department using the proper part number.

AR-505

No.	ITEM	CONTENTS	LIFE	MODEL NAME	REMARKS	
1	Drum	OPC Drum	×1	250K	AR-500DR	
2	Developer (Black)	Developer (800g)	×10	250K (×10)	AR-500CD (AR500SD)	(AR-500SD) ×10 = AR-500CD
3	Toner (Black)	Toner Cartridge (700g)	×10	25K (×10)	AR-500CT (AR-500ST)	(AR-500ST) ×10 = AR-500CT
4	125K PM Kit	Cleaner Blade Charging Plate Unit Waste Toner Bottle Fusing Separation Pawl (upper) Fusing Separation Pawl (lower) Screen Grid Drum Separation Unit Cleaning Roller Upper CL Roller Unit	×1 ×1 ×3 ×4 ×2 ×1 ×1 ×1 ×1	125K	AR-505KA	
5	250K PM Kit	Upper Heat Roller Lower Heat Roller Toner Receiving Seal DV Seal Heat Roller Gear Curl Adjustment Roller	×1 ×1 ×1 ×1 ×1 ×1	250K	AR-505KB	
6	Staple Cartridge	Staple Cartridge (SF-SC11)	×3	5K staples ×3	SF-SC11	Cartridge for AR-FN1/FN1N/FN3 Common with S55,S55 N
7	Cleaner Blade	Cleaner Blade	×10	125K (×10)	AR-330CB	AR-330CB= (AR-330BL) ×10
8	Upper Heat Roller	Upper Heat Roller	×1	250K	AR-505HU	
9	Fusing Separation Pawl (upper)	Fusing Separation Pawl (upper) ×4	×10	125K (×10)	AR-505UP	AR-505UP=AR-505TP (incl.4 pawls) ×10
10	Heat Roller Gear	Heat Roller Gear	×10	250K (×10)	SF-216HG	SF216HG= (SF216JG) ×10
11	Lower Heat Roller	Lower Heat Roller	×1	250K	AR-505HR	
12	Fusing Separation Pawl (lower)	Fusing Separation Pawl (lower) ×2	×10	125K (×10)	SF-240LP	SF240LP=Sf-240MP (incl.2 pawls) ×10
13	Drum Separation Pawl	Drum Separation Pawl ×2	×10	125K (×10)	AR-505DP	AR-505DP=AR-505EP (incl.2 pawls) ×10
14	Screen Grid	Screen Grid	×10	125K (×10)	AR-330SU	AR-330SU= (AR-330TU) ×10
15	Charging Plate	Charging Plate	×10	125K (×10)	AR-330PU	AR-330PU= (AR-330NU) ×10
16	Waste Toner Bottle	Waste Toner Bottle	×1		AR-330TB	
17	Busing	Busing ×2	×10	250K (×10)	SF-240BU	SF-240BU= (SF-240DU) ×10
18	Ozone Filter	Ozone Filter	×10	125K (×10)	AR-330FL	AR-330FL= (AR-330JL) ×10
19	Ozone Filter 50	Ozone Filter 50	×10	125K (×10)	AR-505FL	AR-505FL= (AR-505JL) ×10
20	MC Unit	MC Unit	×10		AR-330MC	AR-330MC= (AR-330NC) ×10
21	Curl Adjustment Roller	Curl Adjustment Roller	×10	250K (×10)	AR-505KR	AR-505KR= (AR-505JR) ×10

Note: Maintenance parts other than mentioned above must be ordered through the parts department using the proper part number.

E. Middle East / Africa

AR-250/280/281/285/286/335/336

No.	ITEM	CONTENTS	LIFE	MODEL NAME		REMARKS
				AR-280/285/ 335	AR-250/281/ 286/336	
1	Drum	OPC Drum ×1	160K	AR-330DM	AR-336DM	
2	Developer (Black)	Developer (800g) ×10	80K (×10)	AR-330LD (AR330DV)	AR-336LD (AR-336DV)	AR-330LD = (AR-330DV) × 10 AR-336LD = (AR-336DV) × 10
3	Toner (Black)	Toner Cartridge (700g) ×10	17.5K (×10)	AR-330LT (AR-330T)	AR-400LT (AR-400T)	AR-330LT = (AR-330T) × 10 AR-400LT = (AR-400T) × 10
4	80K PM Kit	Cleaner Blade ×1 Charging Plate Unit ×1 Waste Toner Bottle ×3 Fusing Separation Pawl (upper) ×4 Fusing Separation Pawl (lower) ×2 Screen Grid ×1 Drum Separation Unit ×1	80K	AR-330KA		
5	160K PM Kit	Upper Heat Roller ×1 Lower Heat Roller ×1 Toner Receiving Seal ×1 DV Seal ×1 Heat Roller Gear ×1	160K	AR-330KB		
6	Staple Cartridge	Staple Cartridge (SF-SC11) ×3	5K staples ×3	SF-SC11		Cartridge for AR-FN1 Common with S55,S55 N
7	Staple Cartridge	Staple Cartridge (SF-SC12) ×3	5K staples ×3	SF-LS12		Cartridge for AR-FN2 Common with S54 SF-LS12= (SF-SC12) ×3
8	Cleaner Blade	Cleaner Blade ×10	80K (×10)	AR-330CB		AR-330CB= (AR-330BL) ×10
9	Upper Heat Roller	Upper Heat Roller ×1	160K	AR-330HU		
10	Fusing Separation Pawl (upper)	Fusing Separation Pawl (upper) ×4 ×10	80K (×10)	SF-216UP		SF216UP=SF-216TP (incl.4 pawls) ×10
11	Heat Roller Gear	Heat Roller Gear ×10	160K (×10)	SF-216HG		SF216HG= (SF216JG) ×10
12	Lower Heat Roller	Lower Heat Roller ×1	160K	AR-330HR		
13	Fusing Separation Pawl (lower)	Fusing Separation Pawl (lower) ×2 ×10	80K (×10)	SF-240LP		SF240LP=SF-240MP (incl.2 pawls) ×10
14	Drum Separation Pawl	Drum Separation Pawl ×2 ×10	80K (×10)	SF-240DP		SF240DP=SF-240EP (incl.2 pawls) ×10
15	Screen Grid	Screen Grid ×10	80K (×10)	AR-330SU		AR-330SU= (AR-330TU) ×10
16	Charging Plate	Charging Plate ×10	80K (×10)	AR-330PU		AR-330PU= (AR-330NU) ×10
17	Waste Toner Bottle	Waste Toner Bottle ×1		AR-330TB		
18	Busing	Busing ×2 ×10	160K (×10)	SF-240BU		SF-240BU= (SF-240DU) ×10
19	Ozone Filter	Ozone Filter ×10	80K (×10)	AR-330FL		AR-330FL= (AR-330JL) ×10
20	Copy Lamp	Copy Lamp ×10		AR-330CL		AR-330CL= (AR-330DL) ×10
21	MC Unit	MC Unit ×10		AR-330MC		AR-330MC= (AR-330NC) ×10

Note: Maintenance parts other than mentioned above must be ordered through the parts department using the proper part number.

AR-405

No.	ITEM	CONTENTS	LIFE	MODEL NAME	REMARKS	
1	Drum	OPC Drum ×1	180K	AR-400DM		
2	Developer (Black)	Developer (800g) ×10	90K (×10)	AR-400LD	AR-400LD = (AR-400DV) × 10	
3	Toner (Black)	Toner Cartridge (700g) ×10	22K (×1)	AR-400LT	AR-400LT = (AR-400T) × 10	
4	90K PM Kit	Cleaner Blade ×1 Charging Plate Unit ×1 Waste Toner Bottle ×3 Fusing Separation Pawl (upper) ×4 Fusing Separation Pawl (lower) ×2 Screen Grid ×1 Drum Separation Unit ×1	90K	AR-400KA		
5	180K PM Kit	Upper Heat Roller ×1 Lower Heat Roller ×1 Toner Receiving Seal ×1 DV Seal ×1 Heat Roller Gear ×1	180K	AR-400KB		
6	Staple Cartridge	Staple Cartridge (SF-SC11) ×3	5K staples ×3	SF-SC11		Cartridge for AR-FN1 Common with S55,S55 N
7	Staple Cartridge	Staple Cartridge (SF-SC12) ×3	5K staples ×3	SF-LS12		Cartridge for AR-FN2 Common with S54 SF-LS12= (SF-SC12) ×3
8	Cleaner Blade	Cleaner Blade ×10	90K (×10)	AR-330CB		AR-330CB= (AR-330BL) ×10
9	Upper Heat Roller	Upper Heat Roller ×1	180K	AR-400HU		
10	Fusing Separation Pawl (upper)	Fusing Separation Pawl (upper) ×4 ×10	90K (×10)	SF-216UP		SF216UP=SF-216TP (incl.4 pawls) ×10
11	Heat Roller Gear	Heat Roller Gear ×10	180K (×10)	SF-216HG		SF216HG= (SF216JG) ×10
12	Lower Heat Roller	Lower Heat Roller ×1	180K	AR-330HR		
13	Fusing Separation Pawl (lower)	Fusing Separation Pawl (lower) ×2 ×10	90K (×10)	SF-240LP		SF240LP=SF-240MP (incl.2 pawls) ×10
14	Drum Separation Pawl	Drum Separation Pawl ×2 ×10	90K (×10)	SF-240DP		SF240DP=SF-240EP (incl.2 pawls) ×10
15	Screen Grid	Screen Grid ×10	90K (×10)	AR-330SU		AR-330SU= (AR-330TU) ×10
16	Charging Plate	Charging Plate ×10	90K (×10)	AR-330PU		AR-330PU= (AR-330NU) ×10
17	Waste Toner Bottle	Waste Toner Bottle ×1		AR-330TB		
18	Busing	Busing ×2 ×10	180K (×10)	SF-240BU		SF-240BU= (SF-240DU) ×10
19	Ozone Filter	Ozone Filter ×10	90K (×10)	AR-330FL		AR-330FL= (AR-330JL) ×10
20	Copy Lamp	Copy Lamp ×10		AR-330CL		AR-330CL= (AR-330DL) ×10
21	MC Unit	MC Unit ×10		AR-330MC		AR-330MC= (AR-330NC) ×10

Note: Maintenance parts other than mentioned above must be ordered through the parts department using the proper part number.

AR-505

No.	ITEM	CONTENTS	LIFE	MODEL NAME	REMARKS
1	Drum	OPC Drum ×1	250K	AR-500DM	
2	Developer (Black)	Developer (800g) ×10	250K (×10)	AR-500LD (AR500DV)	(AR-500DV) ×10 = AR-500LD
3	Toner (Black)	Toner Cartridge (700g) ×10	25K (×10)	AR-500LT (AR-500T)	(AR-500T) ×10 = AR-500LT
4	125K PM Kit	Cleaner Blade ×1 Charging Plate Unit ×1 Waste Toner Bottle ×3 Fusing Separation Pawl (upper) ×4 Fusing Separation Pawl (lower) ×2 Screen Grid ×1 Drum Separation Unit ×1 Cleaning Roller ×1	125K	AR-505KA	
5	250K PM Kit	Upper Heat Roller ×1 Lower Heat Roller ×1 Toner Receiving Seal ×1 DV Seal ×1 Heat Roller Gear ×1 Curl Adjustment Roller ×1 Upper CL Roller Unit ×1	250K	AR-505KB	
6	Staple Cartridge	Staple Cartridge (SF-SC11) ×3	5K staples ×3	SF-SC11	Cartridge for AR-FN1/FN1N/FN3 Common with S55,S55 N
7	Cleaner Blade	Cleaner Blade ×10	125K (×10)	AR-330CB	AR-330CB= (AR-330BL) ×10
8	Upper Heat Roller	Upper Heat Roller ×1	250K	AR-505HU	
9	Fusing Separation Pawl (upper)	Fusing Separation Pawl (upper) ×4	125K (×10)	AR-505UP	AR-505UP=AR-505TP (incl.4 pawls) ×10
10	Heat Roller Gear	Heat Roller Gear ×10	250K (×10)	SF-216HG	SF216HG= (SF216JG) ×10
11	Lower Heat Roller	Lower Heat Roller ×1	250K	AR-505HR	
12	Fusing Separation Pawl (lower)	Fusing Separation Pawl (lower) ×2	125K (×10)	SF-240LP	SF240LP=SF-240MP (incl.2 pawls) ×10
13	Drum Separation Pawl	Drum Separation Pawl ×2	125K (×10)	AR-505DP	AR-505DP=AR-505EP (incl.2 pawls) ×10
14	Screen Grid	Screen Grid ×10	125K (×10)	AR-330SU	AR-330SU= (AR-330TU) ×10
15	Charging Plate	Charging Plate ×10	125K (×10)	AR-330PU	AR-330PU= (AR-330NU) ×10
16	Waste Toner Bottle	Waste Toner Bottle ×1		AR-330TB	
17	Busing	Busing ×2	250K (×10)	SF-240BU	SF-240BU= (SF-240DU) ×10
18	Ozone Filter	Ozone Filter ×10	125K (×10)	AR-330FL	AR-330FL= (AR-330JL) ×10
19	Ozone Filter 50	Ozone Filter 50 ×10	125K (×10)	AR-505FL	AR-505FL= (AR-505JL) ×10
20	MC Unit	MC Unit ×10		AR-330MC	AR-330MC= (AR-330NC) ×10
21	Curl Adjustment Roller	Curl Adjustment Roller ×10	250K (×10)	AR-505KR	AR-505KR= (AR-505JR) ×10

Note: Maintenance parts other than mentioned above must be ordered through the parts department using the proper part number.

2. Copy paper

The following conditions for copy quality and transportability of PPC paper must be satisfied. The values are at temperature of $20 \pm 1^\circ\text{C}$ and $65 \pm 2\%$ RH.

Item	Standard
Weight	56 ~ 80g/m ²
Smoothness	Face: 20 sec or above (BEKK method) Back: 20 sec or above (BEKK method)
Rigidity	Length 17cm or above, width 13cm or above (CLARK method)
Thickness	75 ~ 110 μ
Dimensions	Standard dimensions $\pm 1\text{mm}$ (5/128") B4 (257 ± 1 \times 364 $\pm 1\text{mm}$) B5 (182 ± 1 \times 257 $\pm 1\text{mm}$) B6 (128 ± 1 \times 182 $\pm 1\text{mm}$) A3 (297 ± 1 \times 420 $\pm 1\text{mm}$) A4 (210 ± 1 \times 297 $\pm 1\text{mm}$) A5 (148 ± 1 \times 210 $\pm 1\text{mm}$) A6 (105 ± 1 \times 148 $\pm 1\text{mm}$) 11" $\pm 5/128$ \times 17" $\pm 5/128$ inch 8.5" $\pm 5/128$ \times 14" $\pm 5/128$ inch 8.5" $\pm 5/128$ \times 11" $\pm 5/128$ inch 5.5" $\pm 5/128$ \times 8.5" $\pm 5/128$ inch 8.5" $\pm 5/128$ \times 13" $\pm 5/128$ inch

3. Environment conditions

A. Transport conditions

1) Transport condition

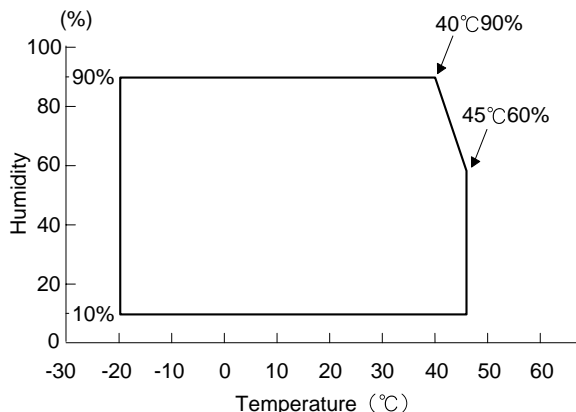

2) Storage condition (packed conditions)

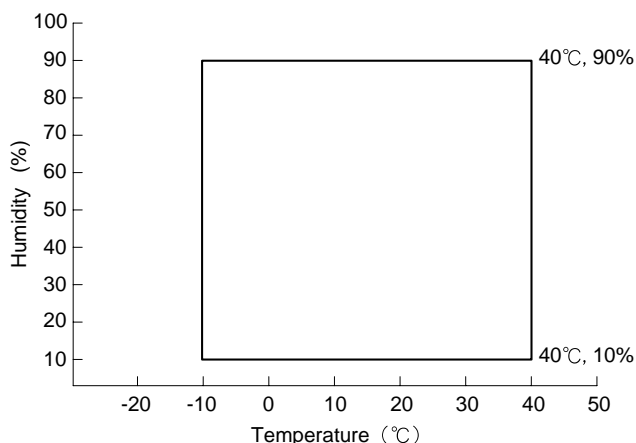

B. Use conditions

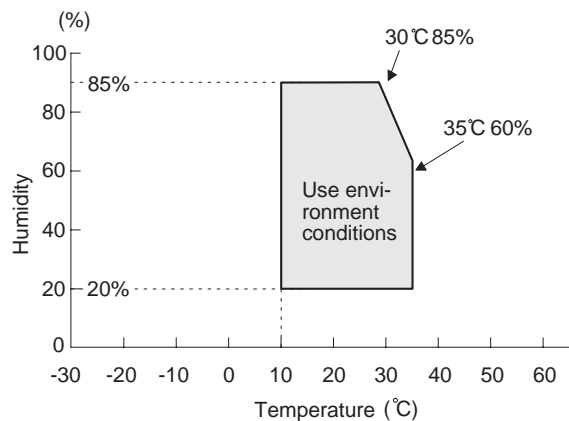

C. Life (packed conditions)

Photoconductor drum (36 months from the production month)

Developer, toner (24 months from the production month)

4. Production number identification

A. Photoconductor drum

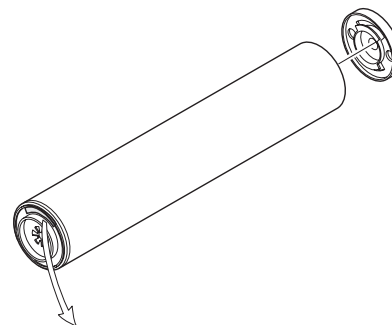

<TYPE A>

1	2	3	4	5	6	7	8	9	10
---	---	---	---	---	---	---	---	---	----

	AR-280/285/335	AR-250/281/286/ 336/405
1	Numeral The sensitivity of the photo conductor.	
2	Alphabet The model code, "C" for this model.	Alphabet The model code, "D" for this model.
3	Numeral The last digit of the production year.	
4	Numeral or X, Y, Z The production month. X means October, Y November, and Z December.	
5, 6	Numeral The production day	
7	Numeral or X, Y, Z The packing month. X stands October, Y November, and Z December.	
8, 9	Numeral The packing day.	
10	Alphabet The division of the production factory.	

<TYPE B> (AR-280/285/335/501/505)

11

1	2	3	4	5	6	7	8	9	10
1	Numeral This function: "2"								
2, 3	Alphabet The applicable model. PC (AR-280/285, 335), PH (AR-505) for this model.								
4	Numeral The last digit of the production year.								
5	Numeral or X, Y, Z The production month. X stands for October, Y November, and Z December.								
6	Numeral The production lot.								
7	Numeral The distinction of sub lot.								
8	Numeral or X, Y, Z The packing month. X stands for October, Y November, and Z December.								
9, 10	Numeral The packing day.								
11	Numeral or alphabet The product name of the drum. (except AR-501/505)								

B. Developer/Toner**AR-280/285/335**

1 2 3 4 5 6 — 7

1, 2, 3	Numeral The production lot.
4	Numeral The distinction of sub lot.

AR-405/501/505**<Developer>**

1 2 3 4 5 6 7 8

1	Alphabet The manufacturing factory.
2	Figure The end digit of the production year.
3, 4	Figures The production month.
5, 6, 7, 8	Figures The manufacturing factory management number

<Toner>

1 2 3 4 5 6 7 8

1	Numeral The last digit of the production year.
2	Numeral or alphabet The first digit of the serial No.
3, 4, 5, 6, 7	Numeral Serial No. of one month production
8	Numeral or alphabet The production month.

AR-250/281/286/336**<Developer>**

1 2 3 4 5 6 7 8

1	Alphabet The manufacturing factory.
2	Numeral The last digit of the production year.
3, 4	Numeral The production month.
5, 6, 7	Numeral The last 3 digits of 4-digit production lot number of developer.
8	Numeral Distincts the production lot every 100 cases.

<Toner>

None

<Example>

C9112102 C The manufacturing factory
 9 The year is 1999.
 11 The production month is November.
 210 The production lot number is 1210.
 2 This lot is between 101th case and 200th case production this month.

[4] INSTALLATION AND SETUP

(Copier installation)

1. Unpacking procedures

(1) Packing form

Unpack the copier package in the following procedures.

- 1) Remove the PP bands (4 pcs.).
- 2) Remove the packing case.
- 3) Remove the internal packing pad.
- 4) Remove the copier body.

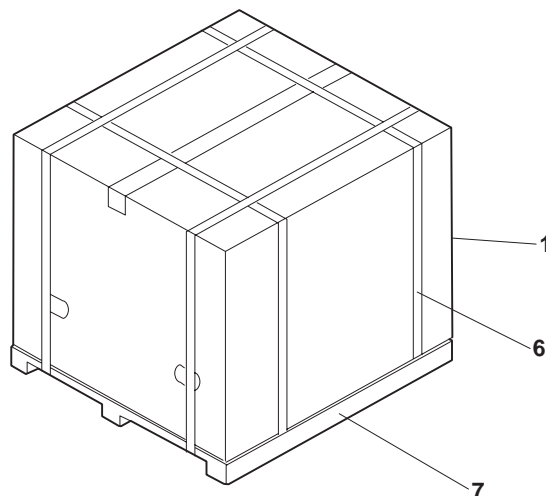
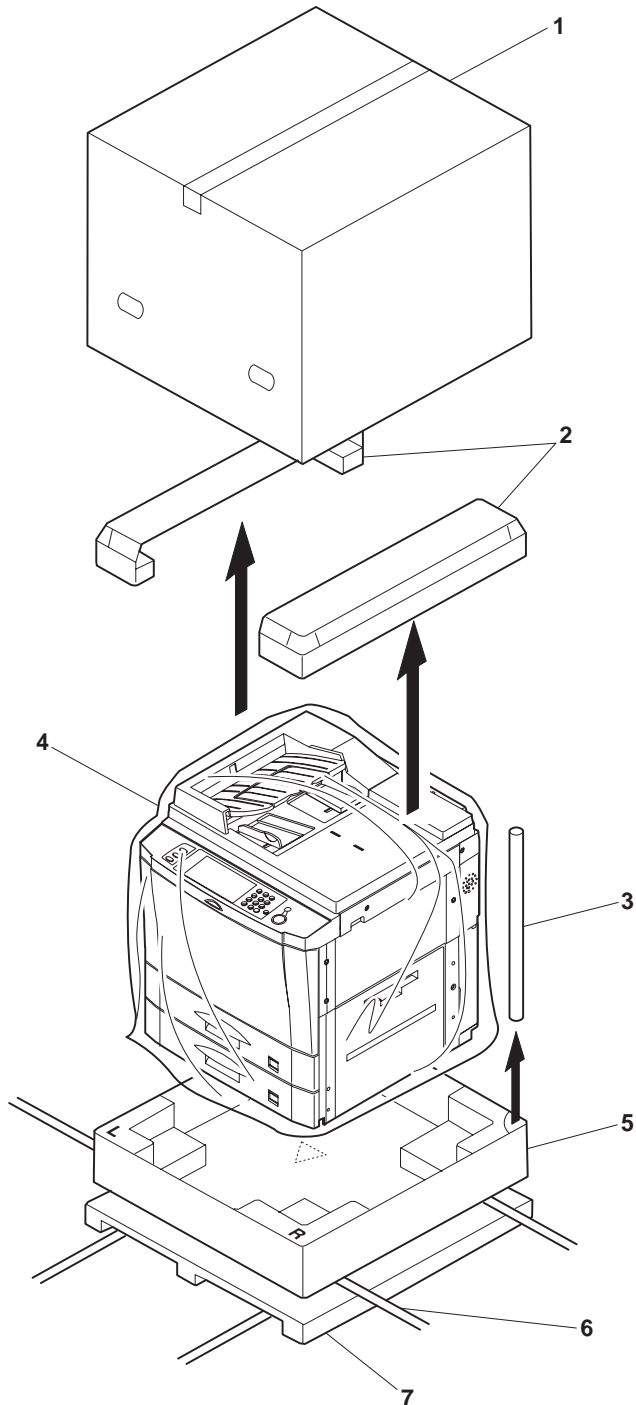

1	Packing case
2	Top pad
3	Support
4	Copier body
5	Bottom case
6	PP band
7	Skid unit

(2) Protection material and fixing material removal

- 1) Remove the fixing tape of the copier body.

In the case of SPF

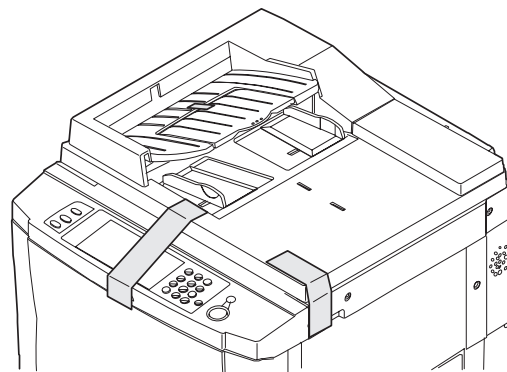

In the case of RADF

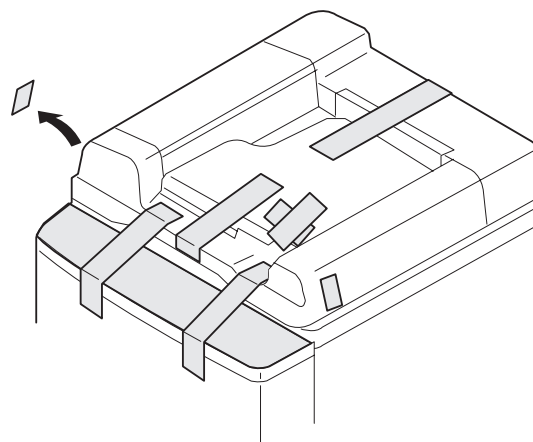

In the case of RSPF

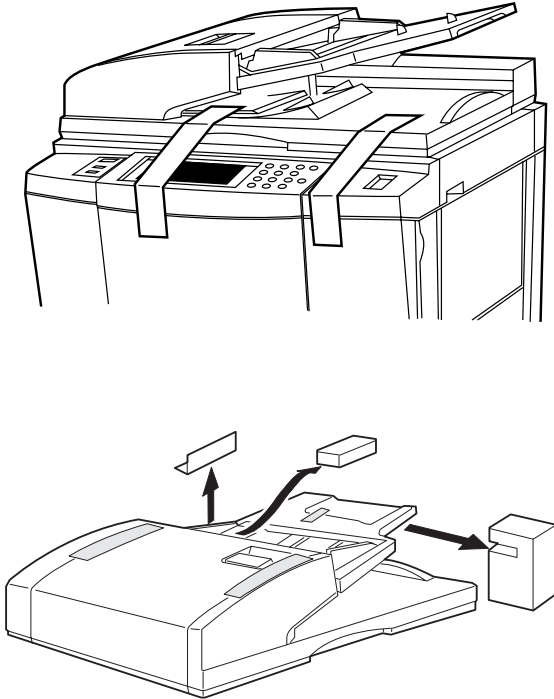

2) Remove the protection material and protection sheet.

In the case of SPF

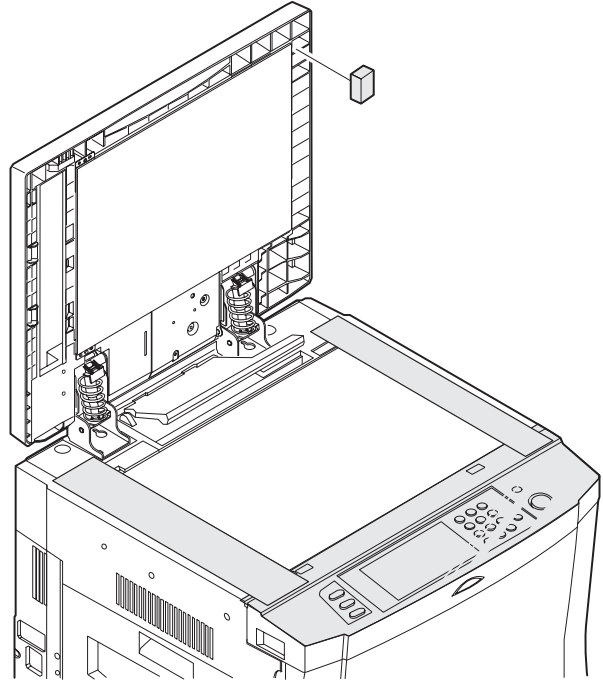

In the case of RADF

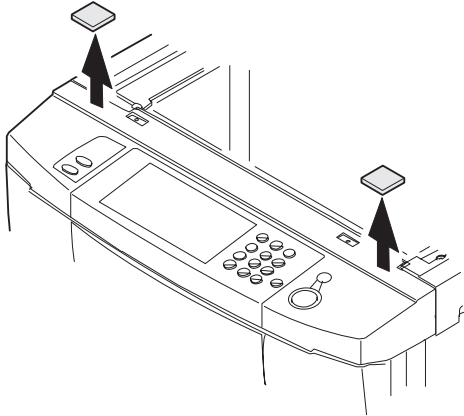
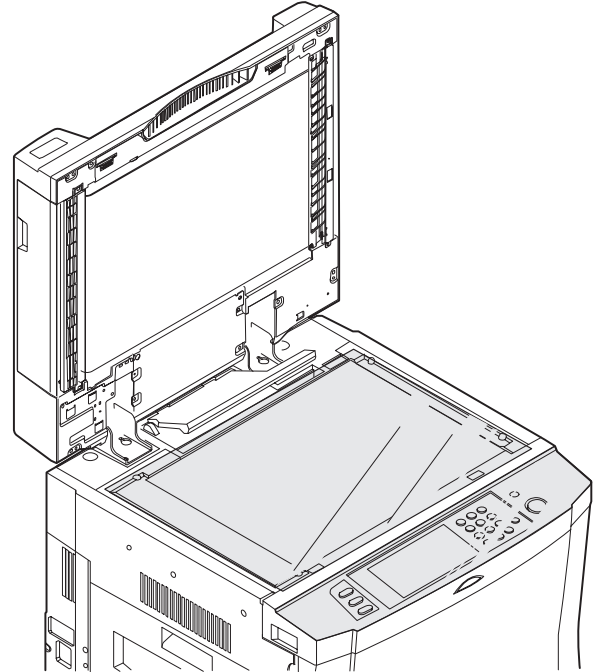

• Paper exit side

• Paper feed side

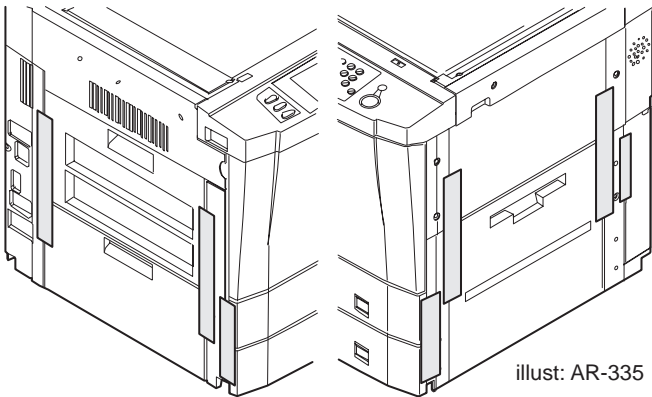

illustr: AR-335

In the case of RSPF

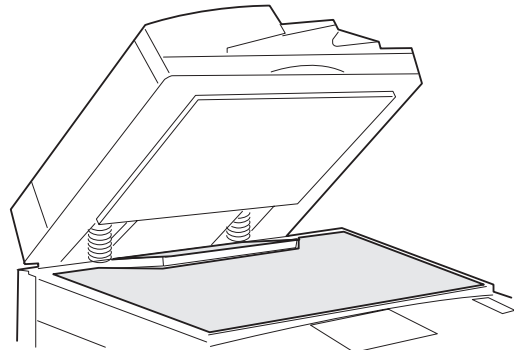

2. Installing procedure

(1) Copier body

A. Optical system lock release

- 1) Release the No. 2/3 mirror unit lock.

Remove the fixing screw (1 pc.) of the No. 2/3 mirror unit on the left side.

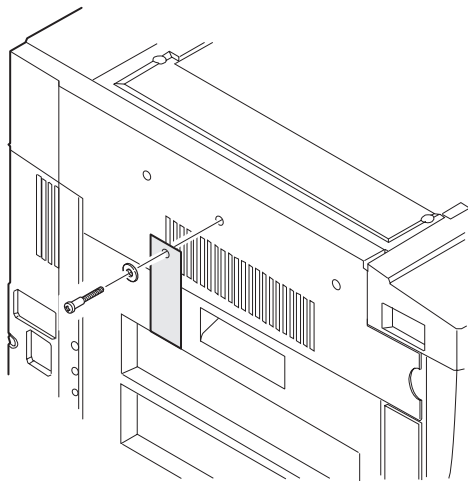

B. Fusing unit

Heat roller pressure check

- 1) Pull out the tray paper exit unit from the copier.
- 2) Check that the heat roller is in pressing state.
(Factory setting: The heat roller is set in pressing state before shipment.)

AR-280/285/335

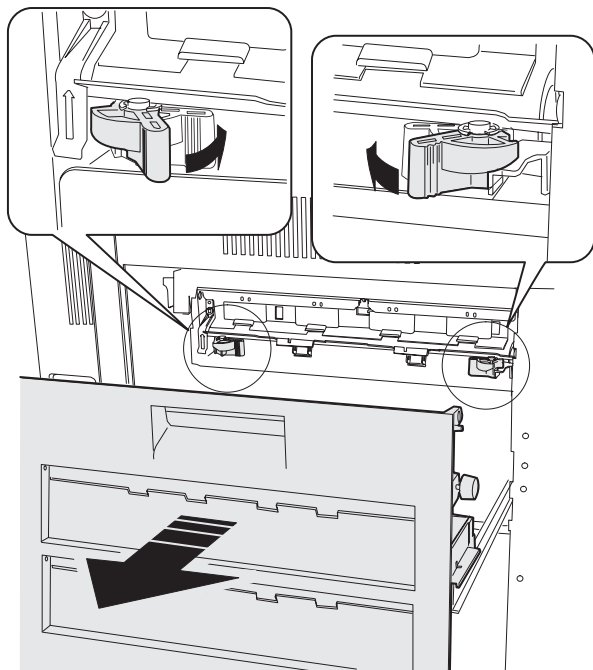

AR-250/281/286/336/405/501/505

Since the pressure lever is not installed, there is no need to check.

C. Charger cleaning

Main charger unit electrode cleaning

- 1) Open the front cabinet
- 2) Press the hook section of the main charger unit to release lock. Pull out and remove the main charger unit from the copier body.

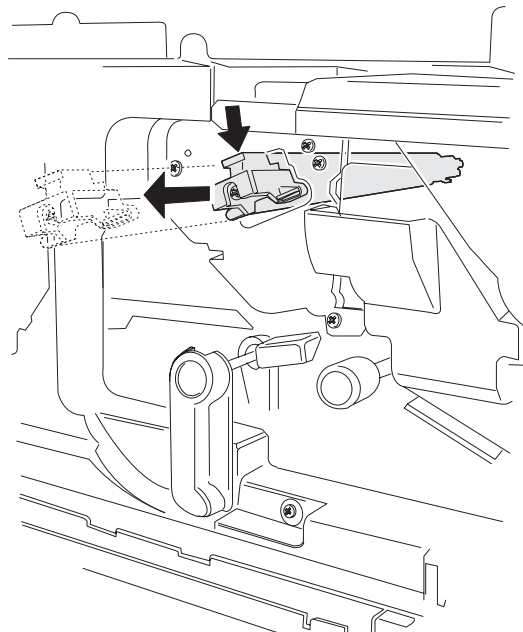

- 3) Remove the fixing screw (1 pc.) of the electrode section on the back of the main charger unit.

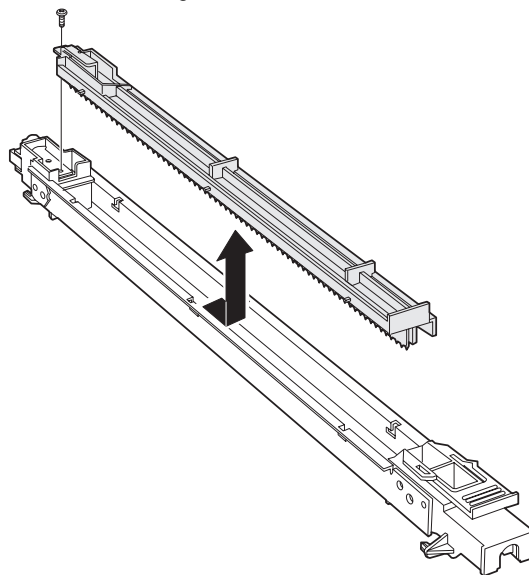

- 4) Push the electrode cleaner onto the electrode tip so that the electrode tip comes into the electrode cleaner to clean. (repeat two or three times.)

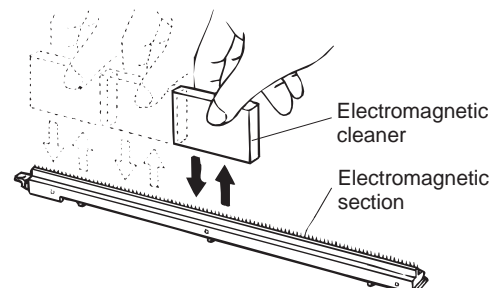

Note: Do not move the electrode cleaner with the electrode tip in it. When cleaning, clean all the electrodes evenly.

- 5) Install the electrode to the original position and fix with the fixing screw (1 pc.).
- 6) Insert the main charger unit completely into the copier along the guide groove.

Transfer/separation charger unit wire cleaning

- 1) Slightly lift the transport section open/close lever and tilt it to the right.

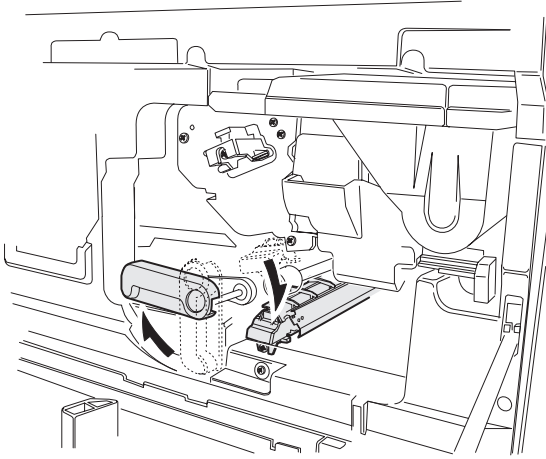

- 2) Remove the driver transfer separation charger fixing screw, and remove the transfer/separation charger unit from the copier body.

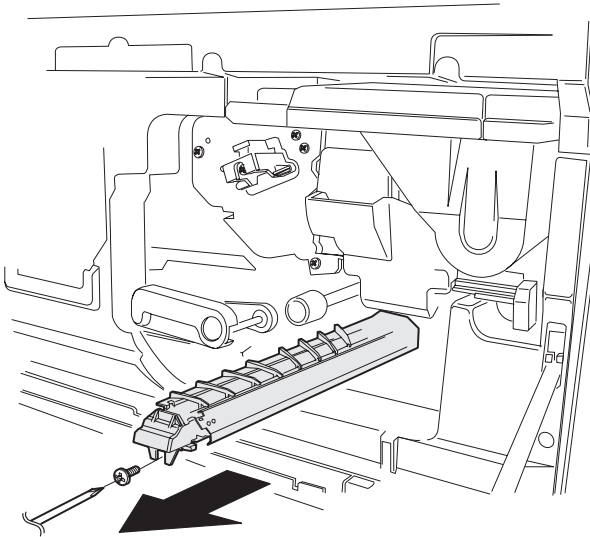

AR-501/505: Perform the following procedure if necessary.

After removing the TC charger in procedure 2), wipe the lamp which can be seen from the square hole of the TC guide rail with waste cloth.

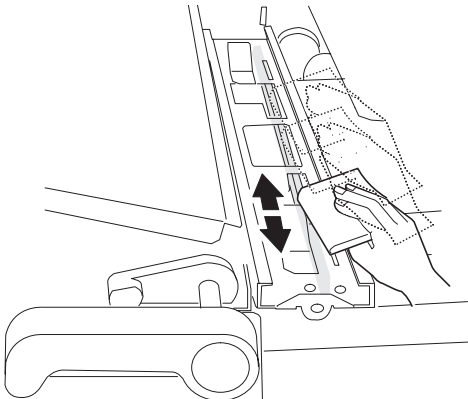

- 3) Remove the separation charger guide from the charger case.

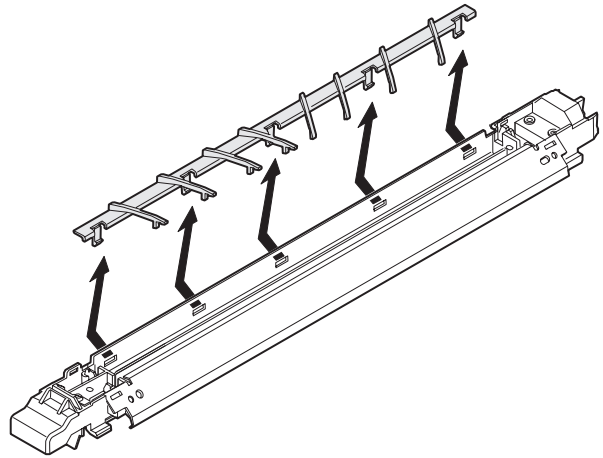

- 4) Squeeze the transfer/separation charger wire with the charger cleaner, and move it in the direction of the arrow which is indicated on the charger to clean.

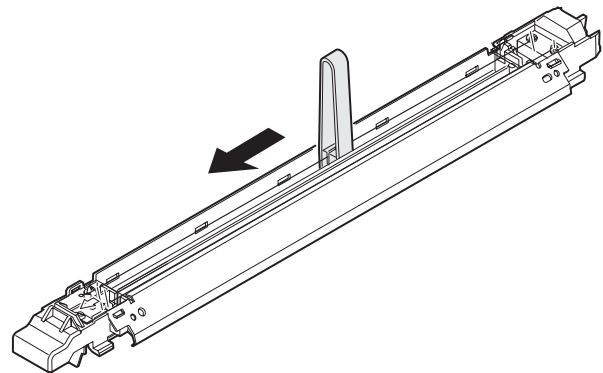

- 5) Install the separation charger to the charger case, and insert the transfer/separation charger unit along the guide groove completely to the bottom.

Then, tighten the transfer/separation charger fixing screw, return the transport section open/close lever to the left, and close the front cabinet.

D. Accessory installation

- 1) Tray installation

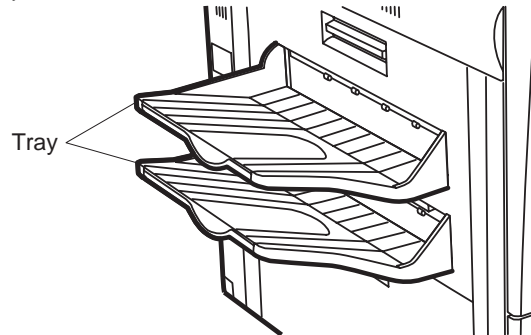

illust: AR-335

E. Upper and lower trays setting

- 1) Remove the tray packing fixing screw.

Lift the tray holder, and pull out the tray from the copier body until it stops.

Remove the packing fixing screw (1 pc.) of the tray paper pressing plate.

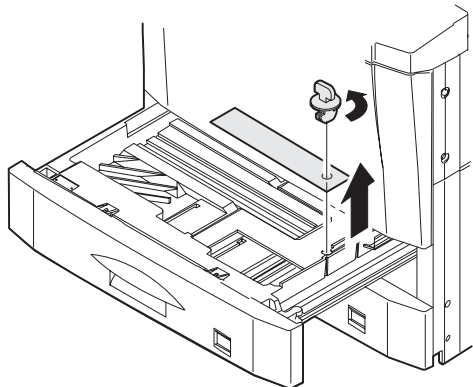

F. Paper size change

- 1) Fit the tray size lever to the size of paper to be used.

(The size lever is of the slide type. Slide it right and left to fit with the size of paper to be used.)

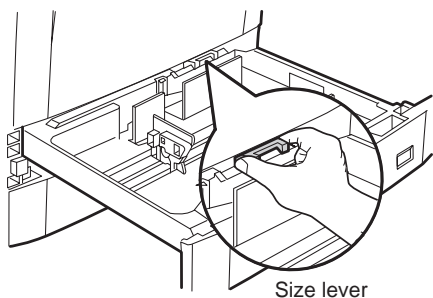

- 2) Fit the partitioning plates A and B to the paper size.

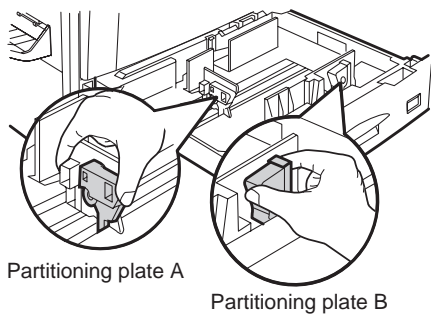

- 3) Put paper on the tray.

Set paper on the tray. At that time, do not exceed the indication line.

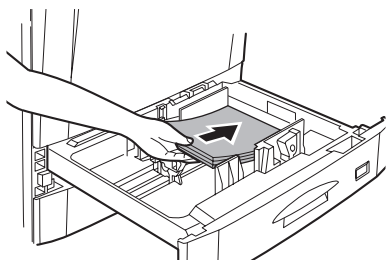

- 4) Change the display of the paper size display.

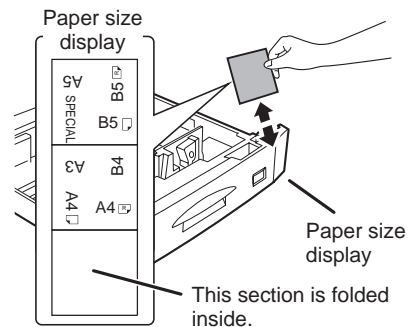

- 5) Install the tray.

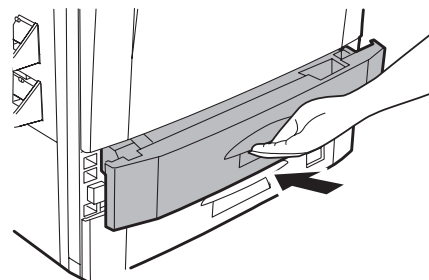

Note: Push the tray completely to the bottom.

G. Developing unit setting

(1) Remove the developing unit

- 1) Open the front cabinet.
- 2) Tilt the developing unit lever toward you, and pull out the toner cartridge until it stops.

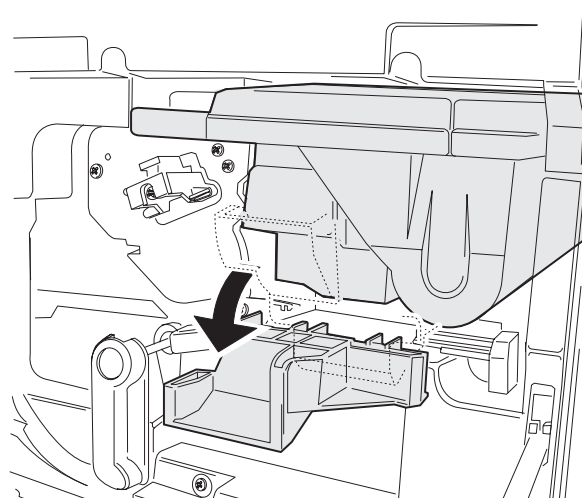

- Slide the developing unit lock lever in the arrow direction to release lock. Hold the toner cartridge holder and slowly pull out the developing unit until it stops.

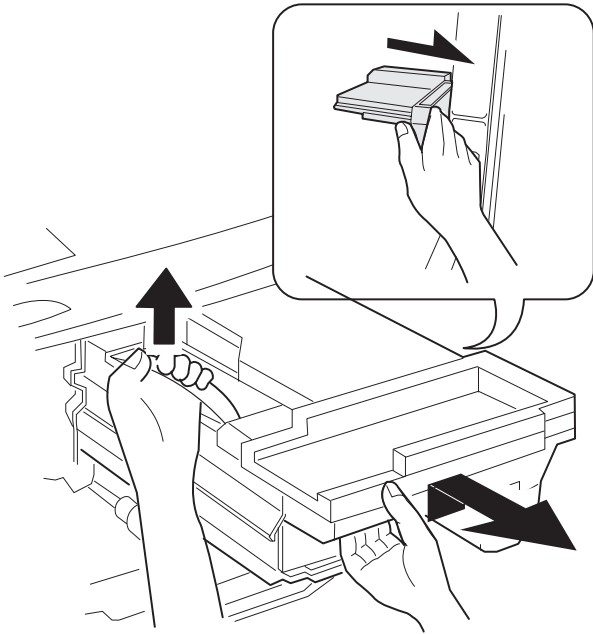

- Hold the developing unit strap, slide the developing unit lock lever in the arrow direction again to release lock, and remove the developing unit.

(2) Supply developer.

- Disconnect the 5P connector which connects the toner hopper and the developing unit. Then remove the toner hopper fixing screws (4 pcs.) of the developing unit.

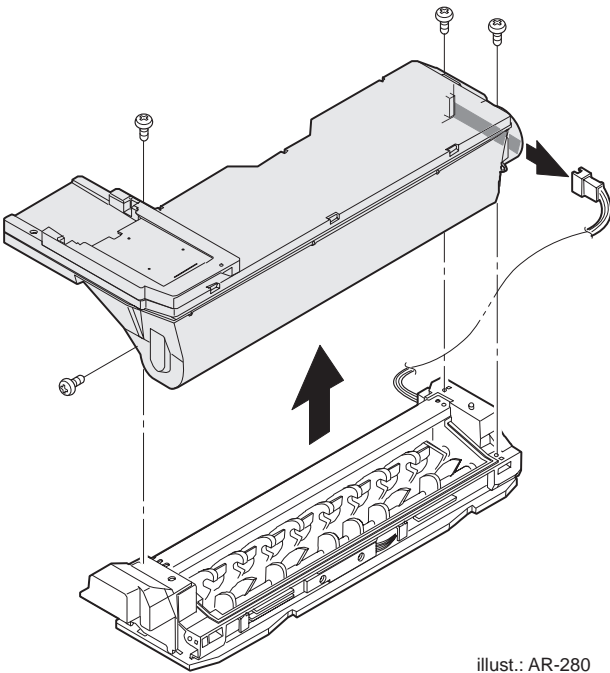

illust.: AR-280

- Supply developer from the developer supply port of the developing unit.

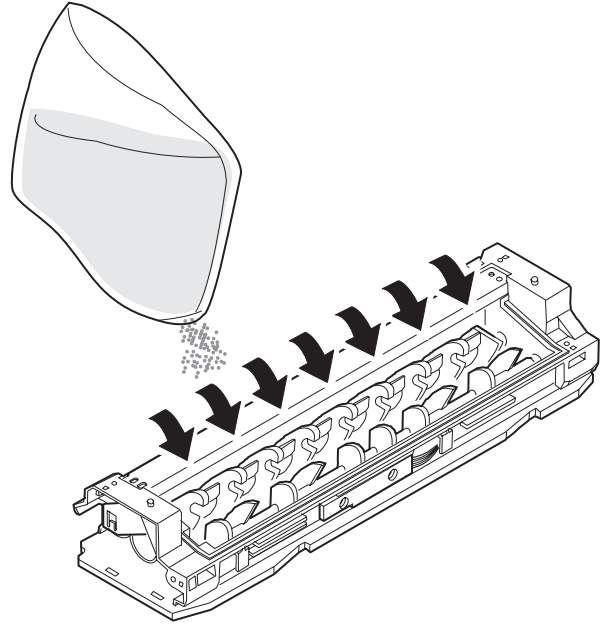

- Fix the toner hopper to the developing unit with the fixing screws (4 pcs.) and connect the 5P connector between the toner hopper and the developing unit. At that time, put the 5P connector harness in the harness clamp attached to the toner hopper, and process the harness.

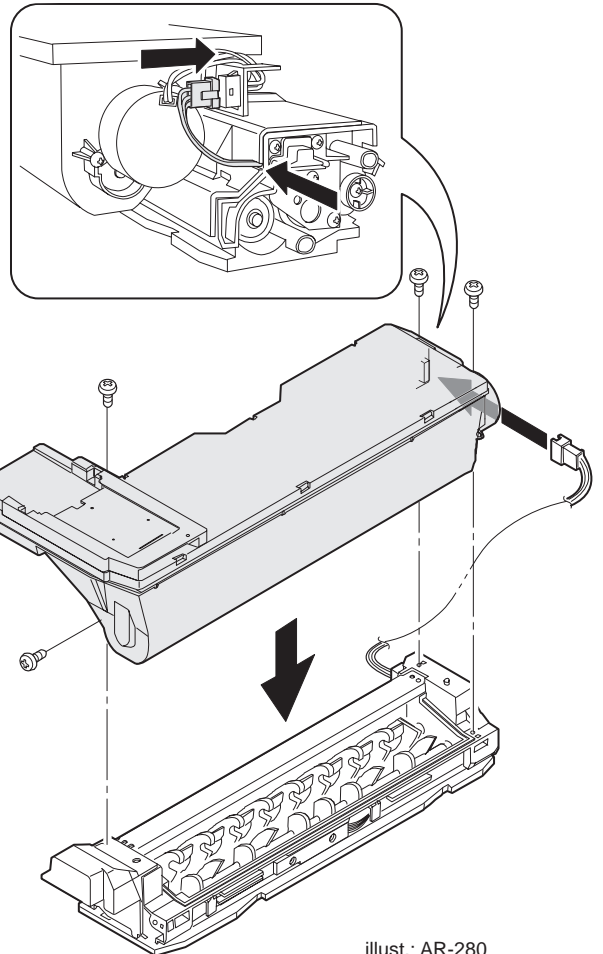

illust.: AR-280

(3) Install the developing unit to the copier body.

Install the developing unit to the copier body and push it into the body completely. Close the developing unit lever and the front cabinet.

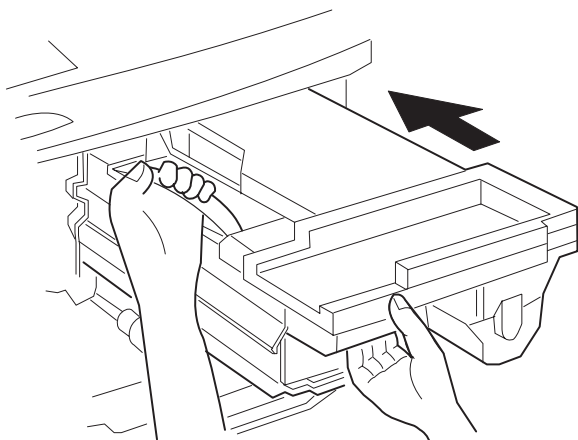

Note: Be careful that this procedure is different from the conventional simulation.

H. Toner density sensor level adjustment

Turn on the power switch of the copier.

Note: Before executing SIM 25-1 or SIM 25-2, be sure to check that the main charger unit is securely inserted.

(1) Adjust the developing unit toner density sensor level.

1) Execute SIM 25-2

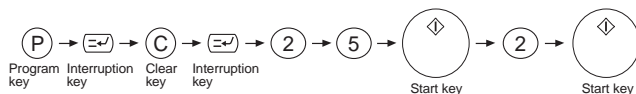

2) The touch panel shows the following display.

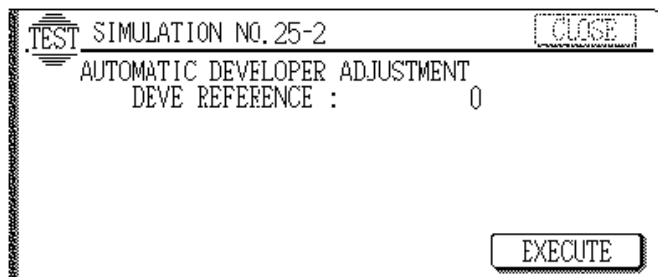

Touch the EXECUTE on the touch panel and execute SIM 25-2.

3) Adjustment is automatically made with the toner density sensor output value displayed. After 3 min from starting stirring, the toner density sensor is sampled 16 times and the average value is stored as the toner density adjustment value.

Note: When the simulation is canceled before completion, automatic reading cannot be made. Be careful not to cancel before completion.

4) Press the [CA] key to cancel SIM 25.

Note: SIM 25-2 must be executed only when developer is replaced. For checking of the developer adjustment value in servicing, use SIM 25-1. (Use of SIM 25-2 to check the developer adjustment value in servicing may cause abnormality in the toner density transition.) Be careful that this simulation is different from the conventional simulations.

I. Toner supply**(1) Supply toner.**

1) Open the front cover.

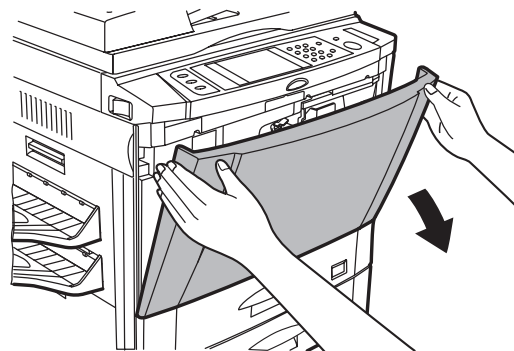

2) Tilt the toner box lever toward you, and pull out the toner box.

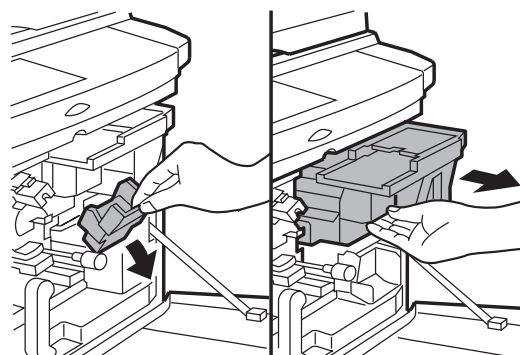

3) Tap the top of the toner cartridge several times, and shake the toner cartridge vertically about 20 times. Turn the toner cartridge upside down, and vigorously shake it vertically about 20 times again.

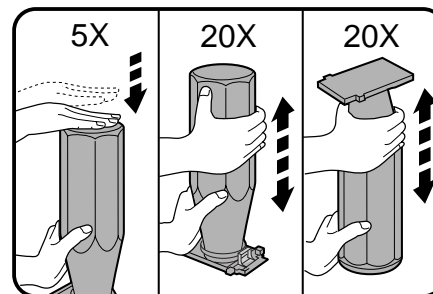

4) Attach the toner cartridge to the toner box.

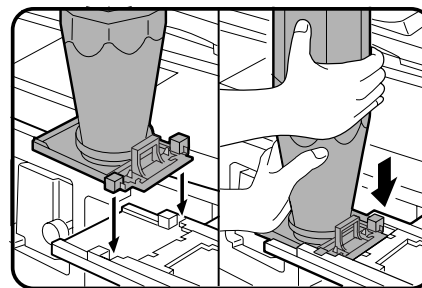
In the case of AR-501/505

In the case of other models

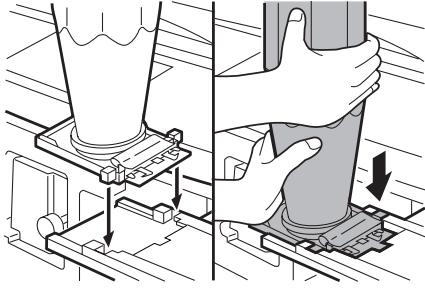

Insert two projections of the toner cartridge into the notches of the toner supply port.

- 5) Move the toner cartridge in the arrow direction until it stops.

In the case of AR-501/505

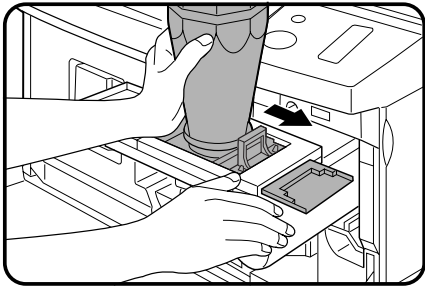

In the case of other models

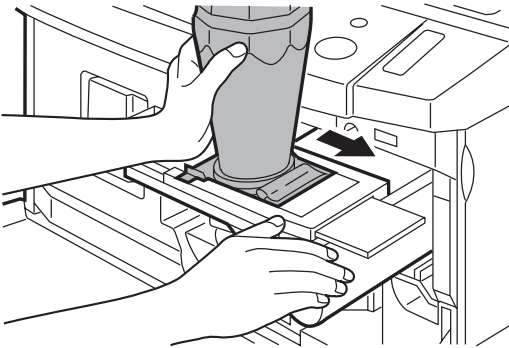

- 6) **In the case of AR-501/505**

Pull the lever in the direction of the arrow until it breaks off. Then pull the lever in the direction of the arrow to remove the seal.

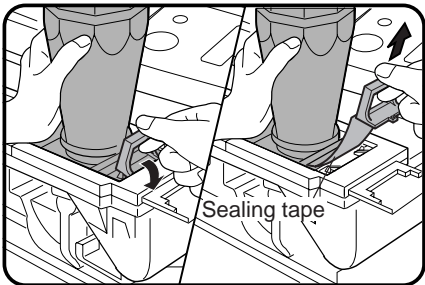

In the case of other models

Take off the seal end and slowly remove it.

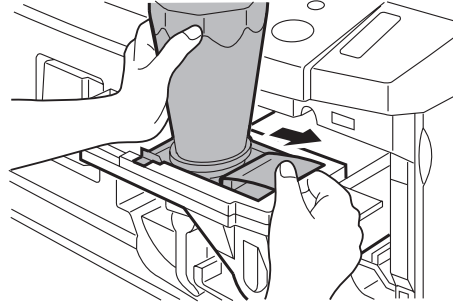

When removing the seal, hold and fix the toner cartridge.

- 7) Tap the top of the toner cartridge several times.

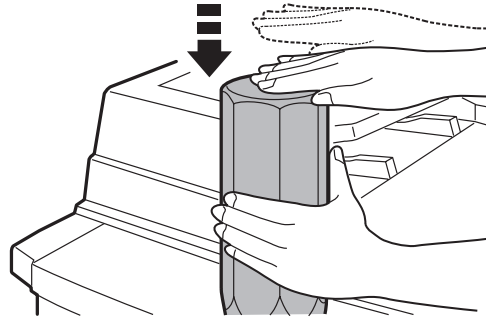

This is to shake off toner attached to the side surface of the toner cartridge.

- 8) Move the empty toner cartridge in the arrow direction and remove it.

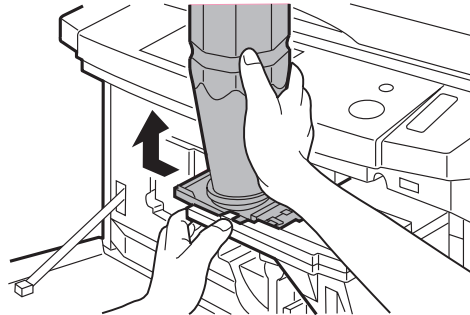

- 9) Push the toner box to the original position, and put the toner box lever to the original position.

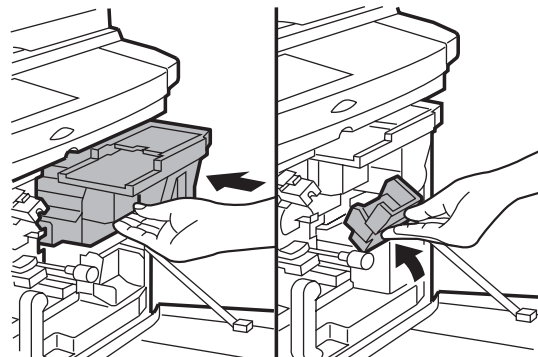

10) Close the front cabinet.

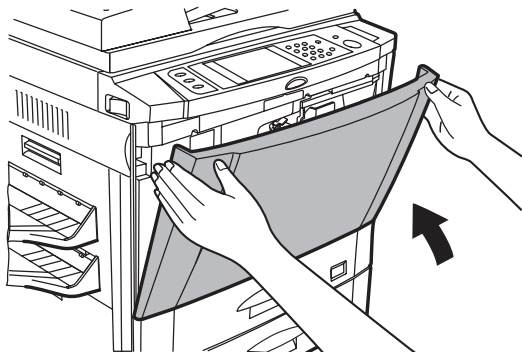

J. Connect the tray connector for RADF

* Temporarily fix tray fixing screw (M4 x 8), and connect the RADF connector with the tray connector.

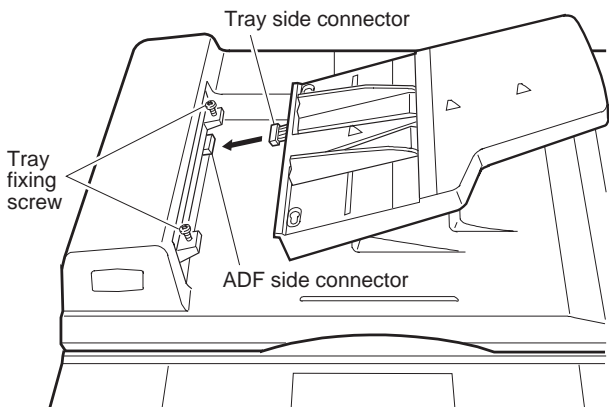

K. Install the tray

* Install the tray as shown in the figure below, and tighten the fixing screws (2 pcs.).

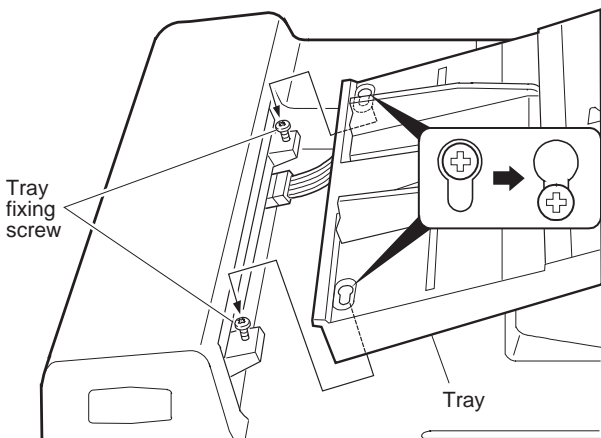

L. Others

(1) Touch panel contrast adjustment

1) Press the CUSTOM SETTINGS key.

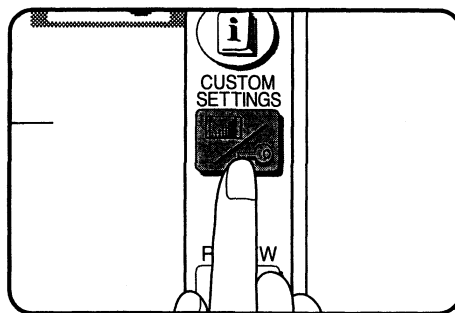

2) Press the "DISPLAY CONTRAST" key on the touch panel.

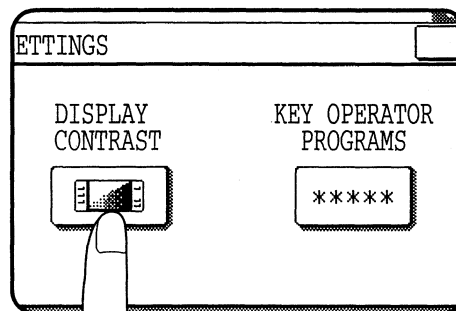

3) Press the "LIGHTER" or "DARKER" key to adjust the contrast.

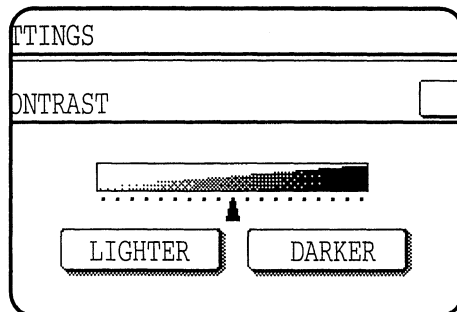

4) Press the "OK" key.

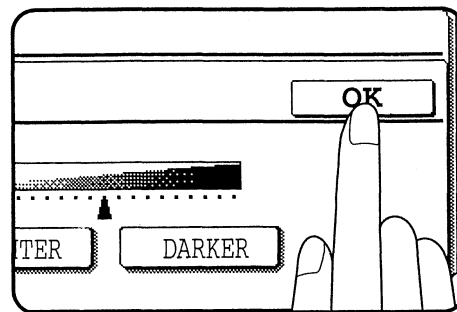

[5] EXTERNAL VIEW AND INTERNAL STRUCTURE

A. Exterior

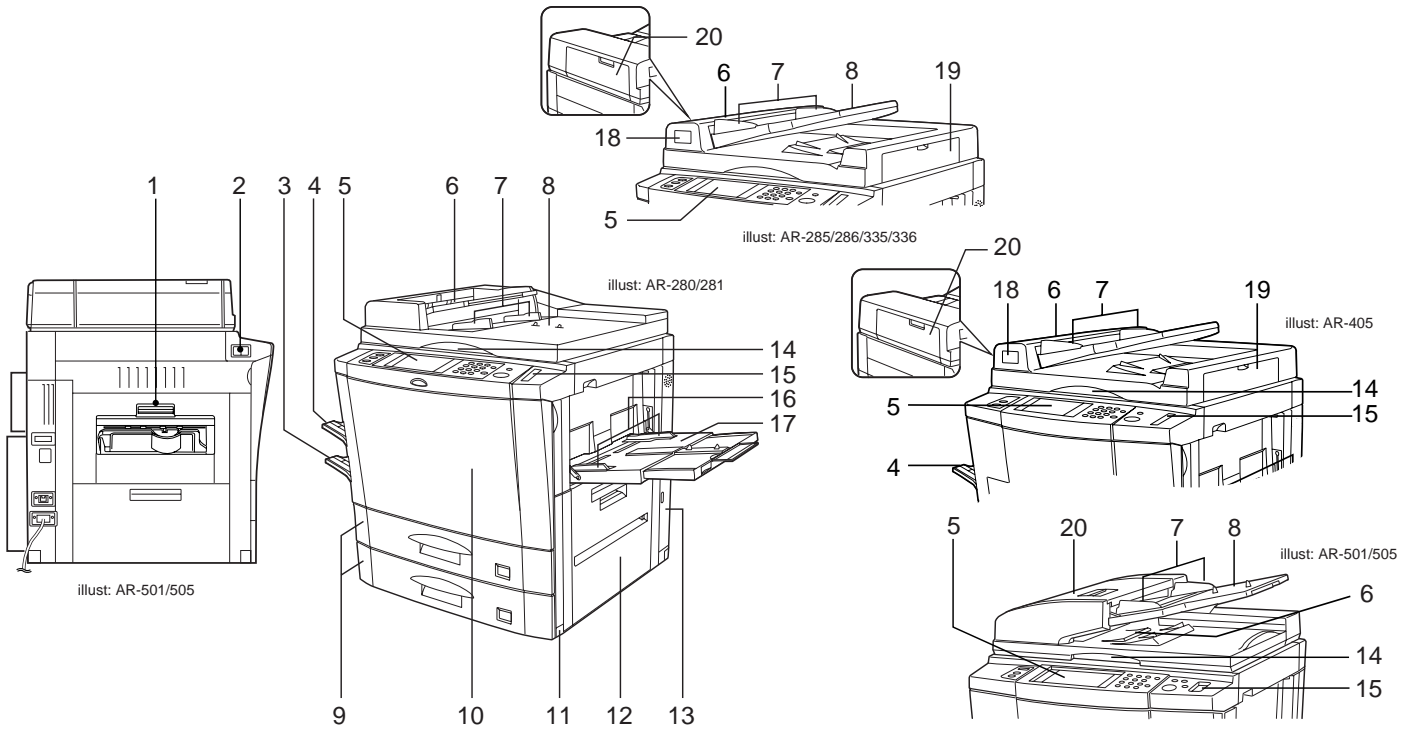

1	Exit area cover	8	Document feeder tray	15	Paper clip tray
2	Power switch	9	Paper trays	16	Bypass tray paper guides
3	Second tray	10	Front cover	17	Bypass tray
4	Output tray	11	Handles	18	Document feeder indicators
5	Operation panel	12	Right side cover	19	RADF exit roller cover
6	SPF/RADF/RSPF exit area	13	Toner collecting container cover	20	RADF/RSPF feeding roller cover
7	Original guides	14	Document glass		

B. Interior

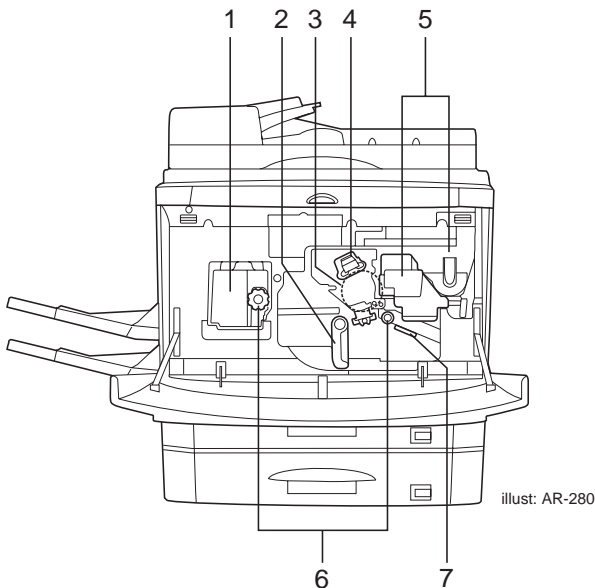

1	Fusing unit
2	Transport lever
3	Photoconductive drum
4	Corona unit
5	Toner hopper
6	Roller rotating knobs
7	Paper guide

C. Operation Panel

(1) Key position

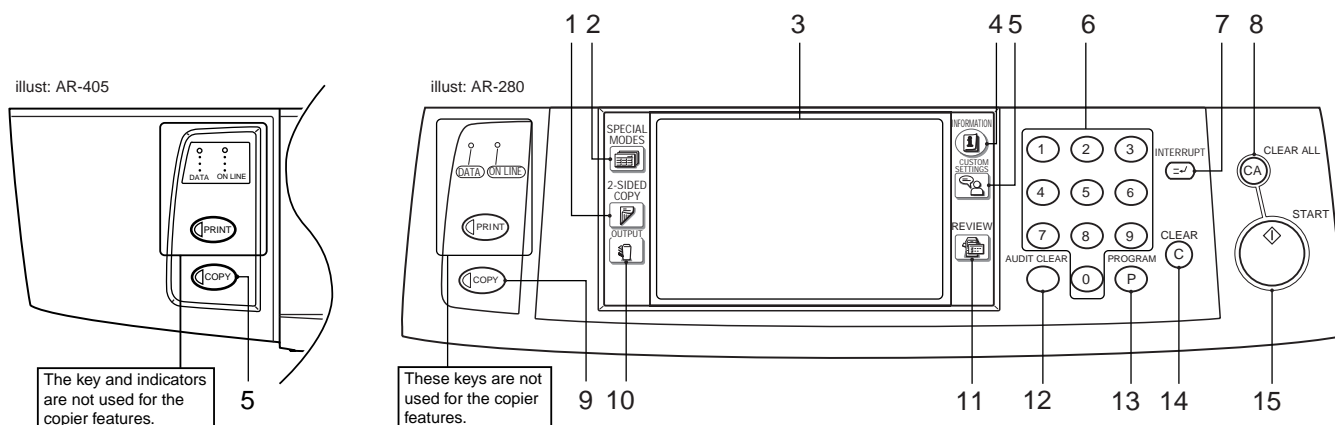

1	2-SIDED COPY key	9	COPY key
2	SPECIAL MODES key	10	OUTPUT key
3	LCD touch panel	11	REVIEW key
4	INFORMATION key	12	AUDIT CLEAR key
5	CUSTOM SETTINGS key	13	PROGRAM key
6	10-key pad	14	Clear key
7	INTERRUPT key and indicator	15	START key and indicator
8	CLEAR ALL key		

(2) Touch Panel

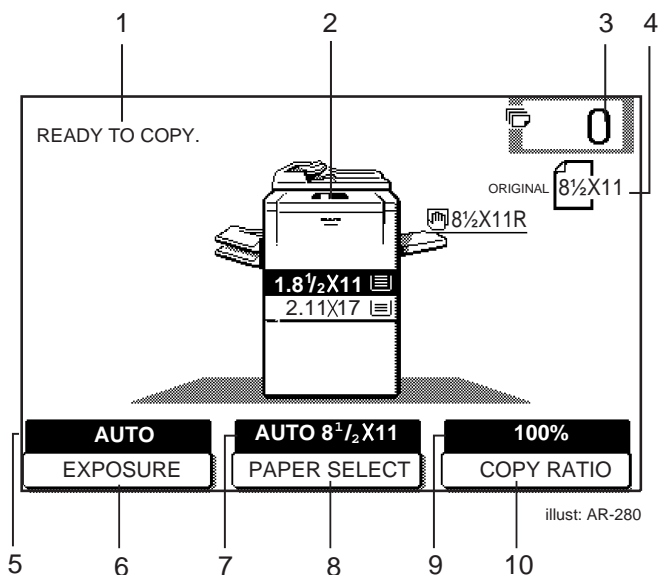

1	Message display
2	Paper size display
3	Copy quantity display
4	Original size display
5	EXPOSURE display
6	EXPOSURE key
7	PAPER SELECT display
8	PAPER SELECT key
9	COPY RATIO display
10	COPY RATIO key

2. Copier body

A. Major parts

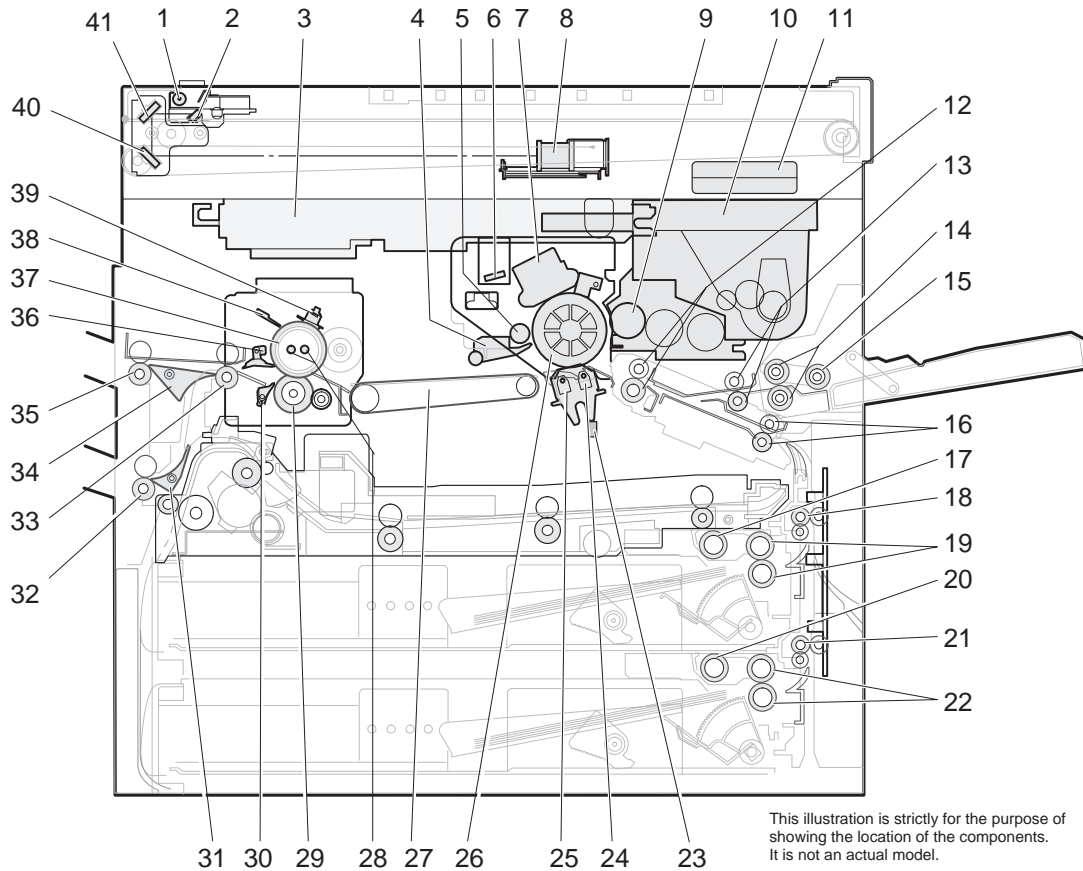

No.	Name
1	Copy lamp
2	No. 1 mirror
3	Laser scanning unit
4	Drum separation pawl
5	Waste toner collecting screw
6	Discharge lamp
7	Main charger
8	CCD unit
9	Developing unit magnet roller
10	Toner hopper
11	Hard disk
12	Resist roller
13	Paper transport roller
14	Manual paper feed tray separation roller
15	Manual paper feed tray paper feed roller
16	Paper transport roller
17	Upper tray paper feed roller
18	Paper transport roller 3
19	Upper tray paper separation roller
20	Lower tray paper feed roller
21	Paper transport roller 4

No.	Name
22	Lower tray paper separation roller
23	Separation lamp
24	Transfer charger
25	Separation charger
26	OPC drum
27	Suction belt
28	Fusing heater lamp (Outside/inside)
29	Lower fusing roller
30	Lower fusing roller separation pawl
31	Lower paper exit tray gate (AR-280/285/335/501/505 only)
32	Paper exit roller 3 (AR-280/285/335 only)
33	Paper exit roller 1 (Curl correction roller for AR-501/505)
34	Upper paper exit tray gate
35	Paper exit roller 2
36	Upper fusing roller separation pawl
37	Upper fusing roller
38	Thermistor (Outside/inside)
39	Thermostat
40	No. 3 mirror
41	No. 2 mirror

B. PWB location

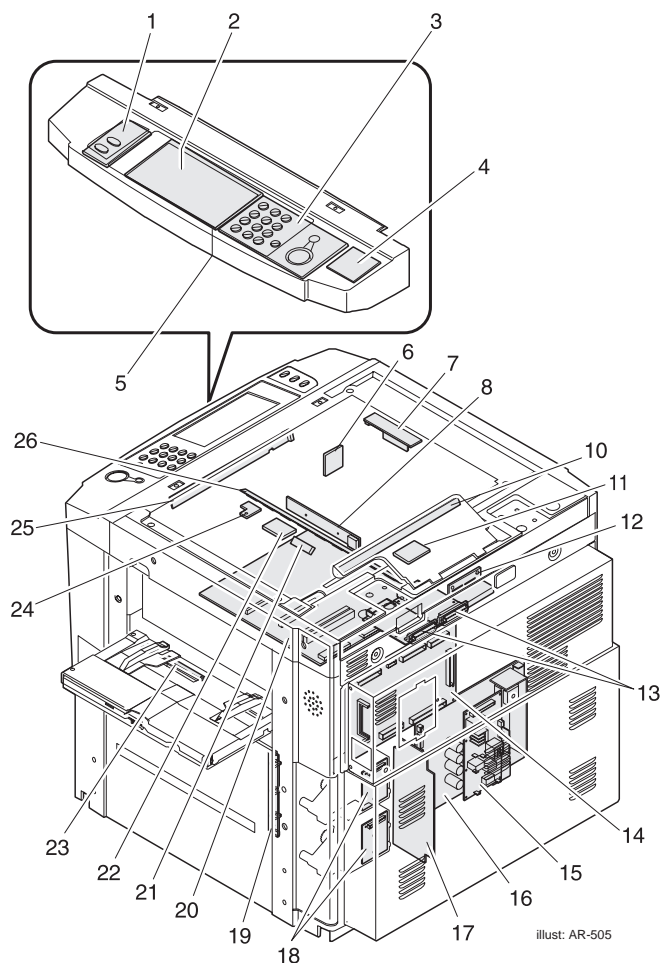
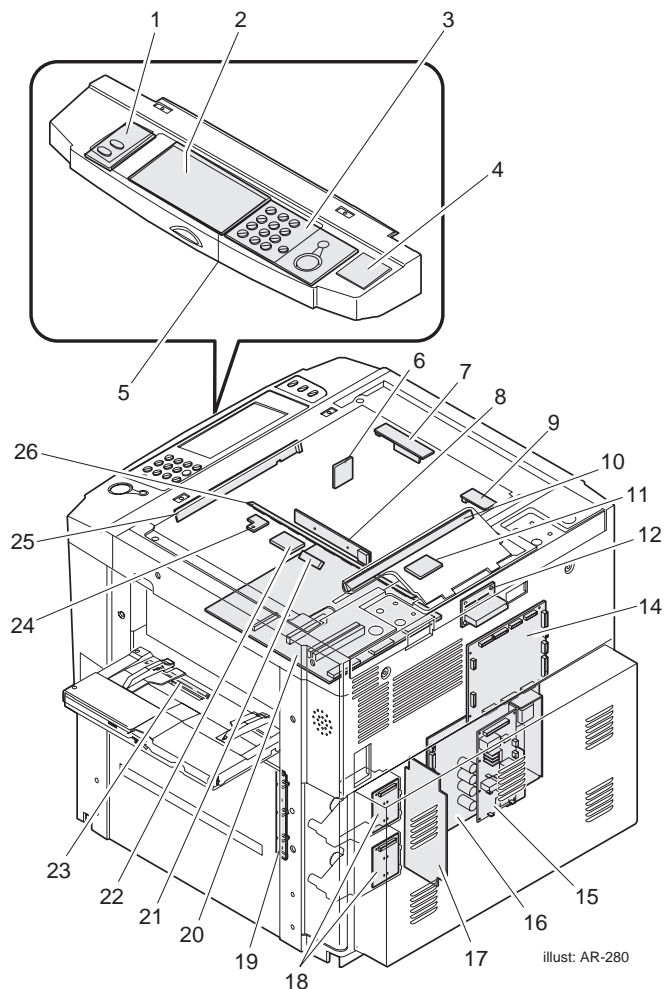

No.	Name	Function, operation
1	Operation key PWB L	Key input
2	LCD unit	Operation input, machine state display
3	Operation key PWB R	Key input
4	Invertor PWB	LCD backlight control
5	Operation control PWB	Operation input, display control
6	Fusing interface PWB	Fusing unit, PCU interface
7	Copy lamp lighting PWB	Copy lamp lighting control
8	CCD PWB	Document image input
9	Copy lamp lighting interface PWB	Copy lamp, PCU interface
10	Document size detecting PWB (Light emitting side)	Document size detection
11	Interface PWB	Interface between the copy lamp and the PCU
12	Scanner driver PWB	Optical system scanner unit drive
13	SCSI interface PWB	Interface between the ICU and the SCSI cable

No.	Name	Function, operation
14	PCU PWB	Overall control of the copier and options
15	AC power PWB	AC power input
16	DC power PWB	DC power supply
17	High voltage PWB	Process high voltage, bias voltage supply
18	Lift-up motor PWB	Paper tray bottom plate lift up
19	Paper transport sensor PWB	Paper transport detection
20	ICU PWB	Image process, image data communication control
21	Process thermistor PWB	Temperature detection in the process unit
22	Drum marking sensor PWB	
23	Multi feed tray paper size detection PWB	Document size detection
24	Process control PWB	
25	Document size detecting PWB (Light receiving side)	Document size detection
26	Discharge lamp PWB	OPC drum discharge

C. Sensor location

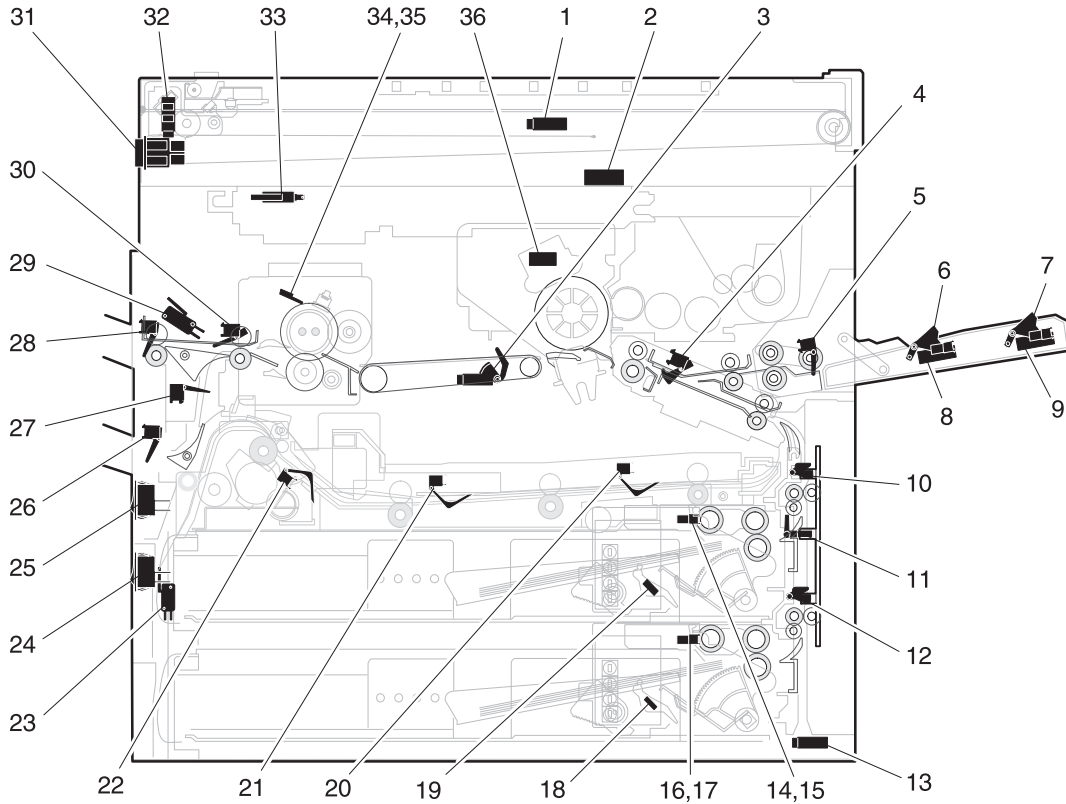

This illustration is strictly for the purpose of showing the location of the components.
It is not an actual model.

No.	Signal name	Function, operation
1	OCSW	Document cover open/close detection
2	Operation PWB thermistor	Operation PWB peripheral temperature detection
3	PSD	Separation detection
4	PPD2	PS paper detection
5	MPED	Manual paper feed paper empty detection
6	MPLD1	Manual paper feed paper length detection 1
7	MPLD2	Manual paper feed paper length detection 2
8	MPLS1	Manual paper fed tray pull-out detection 1
9	MPLS2	Manual paper feed tray pull-out detection 2
10	PPD1	Paper transport detection 1
11	DSWR	Right door open/close detection
12	PFD	Paper transport detection 1
13	TFD	Waste toner full warning detection
14	LUD1	Upper cassette upper limit detection
15	PED1	Upper cassette paper empty detection
16	LUD2	Lower cassette upper limit detection
17	PED2	Lower cassette paper empty detection
18	LCSPD1	No. 2 tray paper remaining detection 1
19	UCSPD1	No. 1 tray paper remaining detection 1
20	DPPD3	ADU tray paper in detection 3
21	DPPD2	ADU tray paper in detection 2

No.	Signal name	Function, operation
22	DPPD1	ADU tray paper in detection 1
23	DSWLL	Left lower door open/close detection
24	DH SW	Dehumidifier heater switch
25	MEM SW	Memory switch
26	POD3	Paper exit detection (Second paper exit)
27	DSBD	ADU reverse section detection
28	POD2	Paper exit detection (ADU)
29	DSWL	Left upper door open/close detection
30	POD1	Paper exit detection (after fusing)
31	MAIN SW	Power switch
32	MHPS	No. 1 mirror home position detection
33	DSWF	Front cover open/close detection
34	Fusing section thermistor (Center)	Heat roller temperature detection
35	Fusing section thermistor (Sides)	Heat roller temperature detection
36	Process section thermistor	Process section peripheral temperature detection

D. Motor location

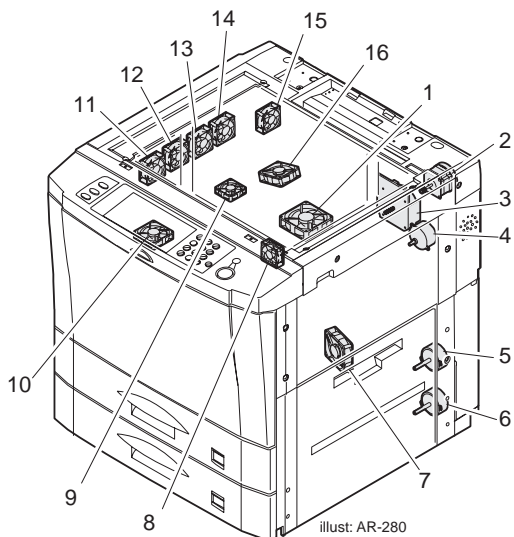

illustr: AR-280

No.	Abbreviation	Name	Type
1	SFM	Suction fan motor	Fan motor
2	SCM	Scanner motor	Stepping motor
3	MM	Main motor	Brushless motor
4	TM	Toner motor	Synchronous motor
5	LUM1	Upper stage lift-up motor	Synchronous motor
6	LUM2	Lower stage lift-up motor	Synchronous motor
7	DCFM	Power fan motor	Fan motor
8	ICUFM	ICU fan motor	Fan motor
9	LSUFM	LSU fan motor	Fan motor
10	PCFM	Process fan motor	Fan motor

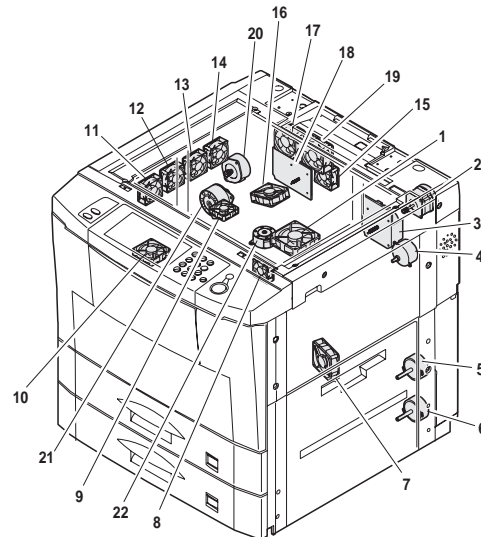

No.	Abbreviation	Name	Type
11	VFM1	Exhaust fan motor 1	Fan motor
12	VFM2	Exhaust fan motor 2	Fan motor
13	VFM4	Exhaust fan motor 4	Fan motor
14	VFM5	Exhaust fan motor 5	Fan motor
15	VFM3	Exhaust fan motor 3	Fan motor
16	VFM6	Exhaust fan motor 6	Fan motor
17	VFM8	Exhaust fan motor 8	Fan motor
18	FSM	Fusing motor	Brushless motor
19	VFM7	Exhaust fan motor 7	Fan motor
20	POM	Paper exit motor	Stepping motor
21	DSBM		Stepping motor
22	PAM		Stepping motor

E. Clutch solenoid

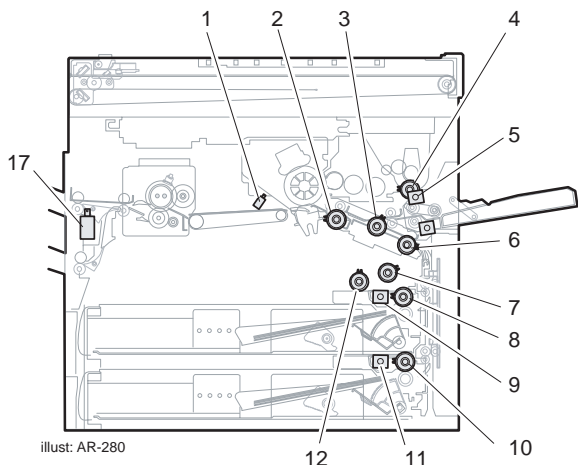

illustr: AR-280

No.	Abbreviation	Function, operation
1	PSPS	Paper separation solenoid
2	RRC	Resist roller clutch
3	MTRC	Transport roller clutch (low)
4	MPFC	Manual paper feed clutch
5	MPFS	Manual paper feed solenoid
6	TRC2	Paper transport clutch
7	TRC1H	Vertical transport roller/paper feed roller high clutch
8	CPFC1	Upper stage cassette paper feed clutch
9	CPFS1	Upper cassette paper feed solenoid

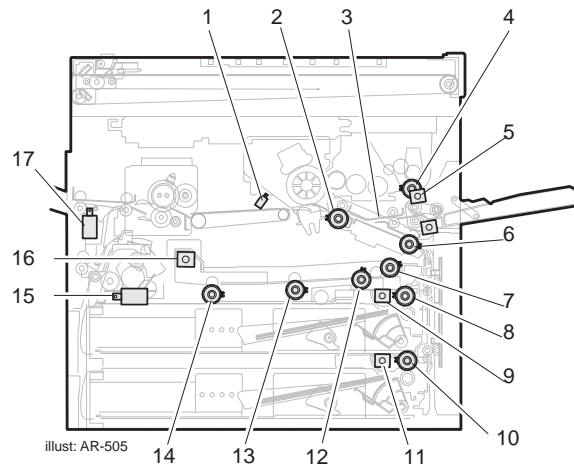

illustr: AR-505

No.	Abbreviation	Function, operation
10	CPFC2	Lower cassette paper feed clutch
11	CPFS2	Lower cassette paper feed solenoid
12	TRC1L	Vertical transport roller/paper feed roller low clutch
13	DTC2	Transport clutch 2
14	DTC1	Transport clutch 1
15	DSBS	Selection of paper exit to the lower stage of the 2-tray paper exit unit and the reverse route
16	DSCS	Selection of paper retaining and transport in paper reversion
17	OGS	Two-stage paper exit tray solenoid

F. 2-tray paper exit unit

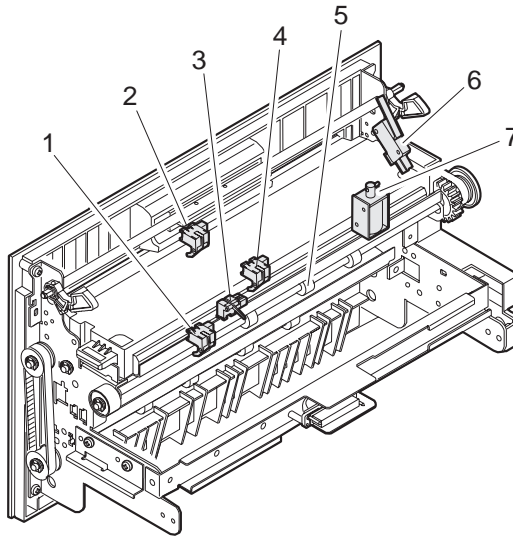

No.	Code	Name	Type	Function and operation
1	POD3	Paper exit detector (Lower stage)	Photo transmission	Detection of paper exit to the lower tray
2	POD2	Paper exit detector (Upper stage)	Photo transmission	Detection of paper exit to the upper tray
3	DSBD	ADU reverse detector	Photo transmission	Detection of reversed paper to the duplex module
4	POD1	Paper exit detector	Photo transmission	Detection of paper exit
5	—	Paper exit roller	—	Paper exit from the tray
6	DSWL		Micro switch	Detection of open and close for paper exit unit
7	DGS	Reverse gate solenoid	Solenoid	Selection of paper exit to the lower tray or to the duplex module

G. SPF (AR-280/281 only)

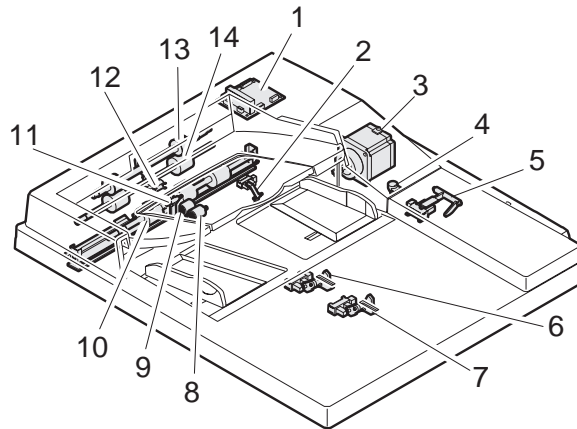

No.	Code	Name	Type	Function and operation
1	—	SPF control PWB	—	—
2	EMPS	Document detector	Photo transmission	Tray document empty detection
3	DTM	Paper feed/transport motor	Stepping motor	Tray document feed/transport/exit roller drive
4	DWVR	Document width sensor	Variable resistor	Tray document width detection
5	OPCLS	Cover open/close detector	Photo transmission	SPF cover open/close detection
6	SIZ2	Document length detector (Small)	Photo transmission	Tray document length detection (for short size)
7	SIZ1	Document length detector (Large)	Photo transmission	Tray document length detection (for long size)
8	—	Document pickup roller	—	—
9	—	Document feed roller	—	—
10	—	Document resist roller	—	—
11	REGS	Resist sensor	Photo transmission	Tray document rear edge detection
12	POS	Document exit sensor	Photo transmission	Tray document exit detection
13	—	Document transport roller	—	—
14	—	Document exit roller	—	—

H. RADF (AR-285/286/335/336/405 only)

1) Main parts

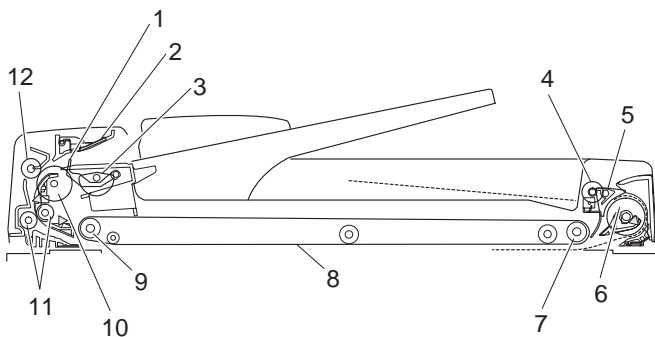

No.	Function, operation
1	Original stopper
2	A21 weight plate
3	Semi-circular roller
4	Paper exit roller
5	Flapper
6	Reverse roller
7	Transport belt follower roller
8	Original transport belt
9	Transport belt drive roller
10	Paper feed roller
11	Resist roller
12	Separation roller

2) PWB distribution

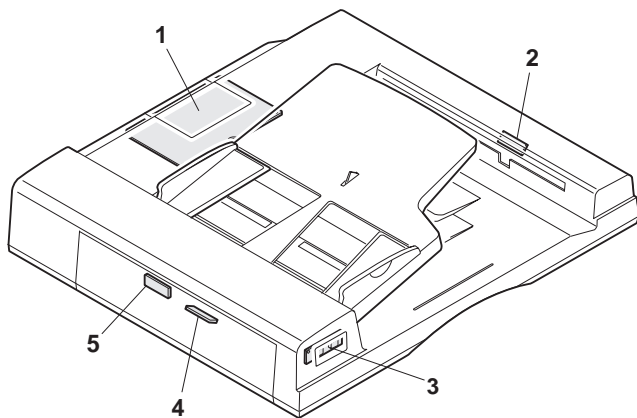

No.	Name	Function, operation
1	Control PWB	RADF unit control, PCU communication
2	Reverse sensor PWB	Document reverse detection
3	LED PWB	Document feed, document remaining display
4	Original timing sensor PWB	Document timing detection
5	Original reverse sensor PWB	Document feed detection

3) Motors, solenoids, and clutches

No.	Code	Name	Type
1	DFM	Paper feed motor	DC motor
2	DTM	Transport motor	Stepping motor
3	DRM	Reverse motor	Stepping motor
4	DRSOL	Reverse solenoid	DC solenoid
5	DFSOL	Paper feed solenoid	DC solenoid

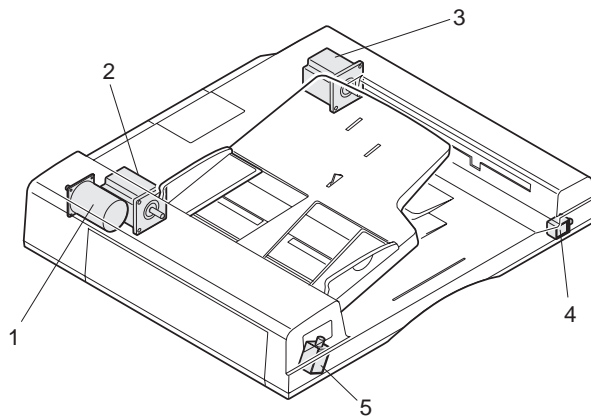

4) Sensors, switches, detectors

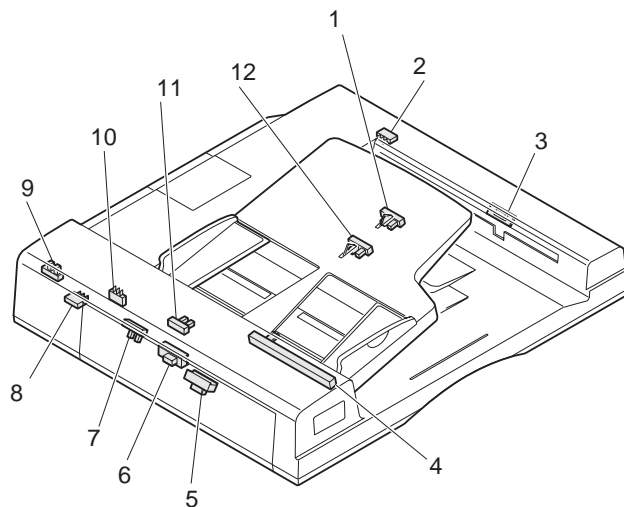

No.	Code	Functions and operations
1	DLS2	Original length detection on the tray (Inch series only)
2	TGOD	Reverse cover open/close detection
3	RDD	Turns HIGH when the original lead edge is transported to the reverse/paper exit path.
4	DWVR	Original width detection on the tray
5	DTD	Turns HIGH when the original lead edge is transported from the paper feed section to the vicinity of the transport belt.
6	DFD	Turns HIGH when the original lead edge is fed just in front of the resist roller.
7	DWS	Original width detection
8	FGOD	Paper feed cover open/close detection
9	DFMRS	Paper feed motor rotation detection
10	AUOD	ADF unit open/close detection
11	DSS	Original detection on the tray
12	DLS1	Original length detection on the tray

I. RSPF (AR-501/505 only)

A. Roller

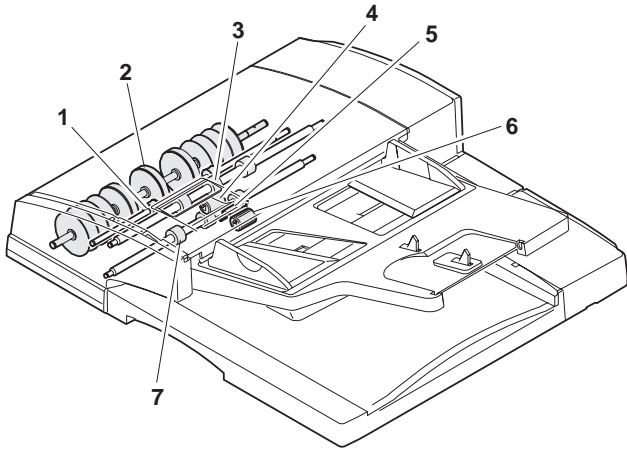

No.	Name
1	Paper exit roller
2	Read roller
3	Resist roller
4	Paper feed roller
5	Separation pad
6	Pickup roller
7	SB roller

B. Sensor, switch, solenoid, motor

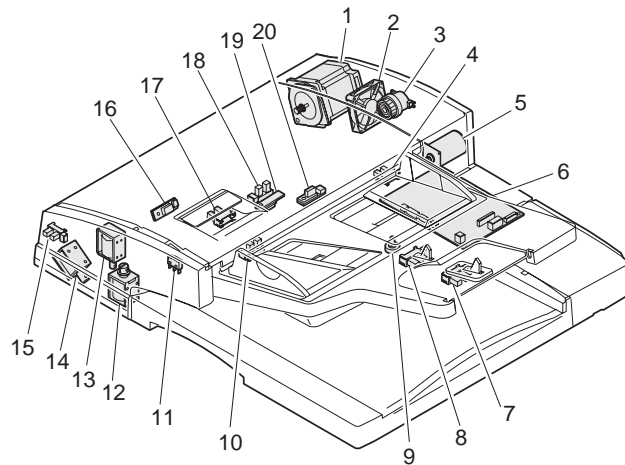

No.	Code	Name	Type	Function and operation
1	FMOT	Transport motor	Stepping motor	Transport and document read motor
2	DCFAN	Fan motor	—	Transport motor cooling fan
3	ACL	Paper feed clutch	—	Document feed clutch
4	MCLKS	DCMCLK	Photo transmission	DC motor encoder sensor
5	AMOT	Paper feed motor	DC motor	Document feed motor
6	PBA-CONTROL	Control PWB	—	RSPF control PWB
7	TRS-L	Tray sensor L	Photo transmission	Document tray longitudinal direction sensor
8	TRS-S	Tray sensor S	Photo transmission	Document tray traverse direction sensor
9	TRVR	Size volume	—	Document tray width direction detection volume
10	EMPS	Empty sensor	Photo transmission	Document sensor set on the document tray
11	JAMOPEN	Jam open switch	—	RSPF jam cover open/close detection
12	SBSOL	Pressure solenoid	—	Reversing path document pressure solenoid
13	FLPSOL2	Flapper solenoid 2	—	Read roller and document exit select solenoid
14	FLPSOL1	Flapper solenoid 1	—	Reversing path and read roller select solenoid
15	DFOPEN	DFOPENF	Photo transmission	RSPF open sensor
16	RDS	Read sensor	Reflection	Document read timing sensor
17	REJI	Resist sensor	Photo transmission	Paper feed resist timing sensor
18	EXITS	Paper exit sensor	Photo transmission	Document exit sensor
19	SBS	SB sensor	Reflection	Reversing path document sensor
20	SPS	Post-separation sensor	Reflection	Feeding document size sensor

J. ADU (AR-285/335/505 only)

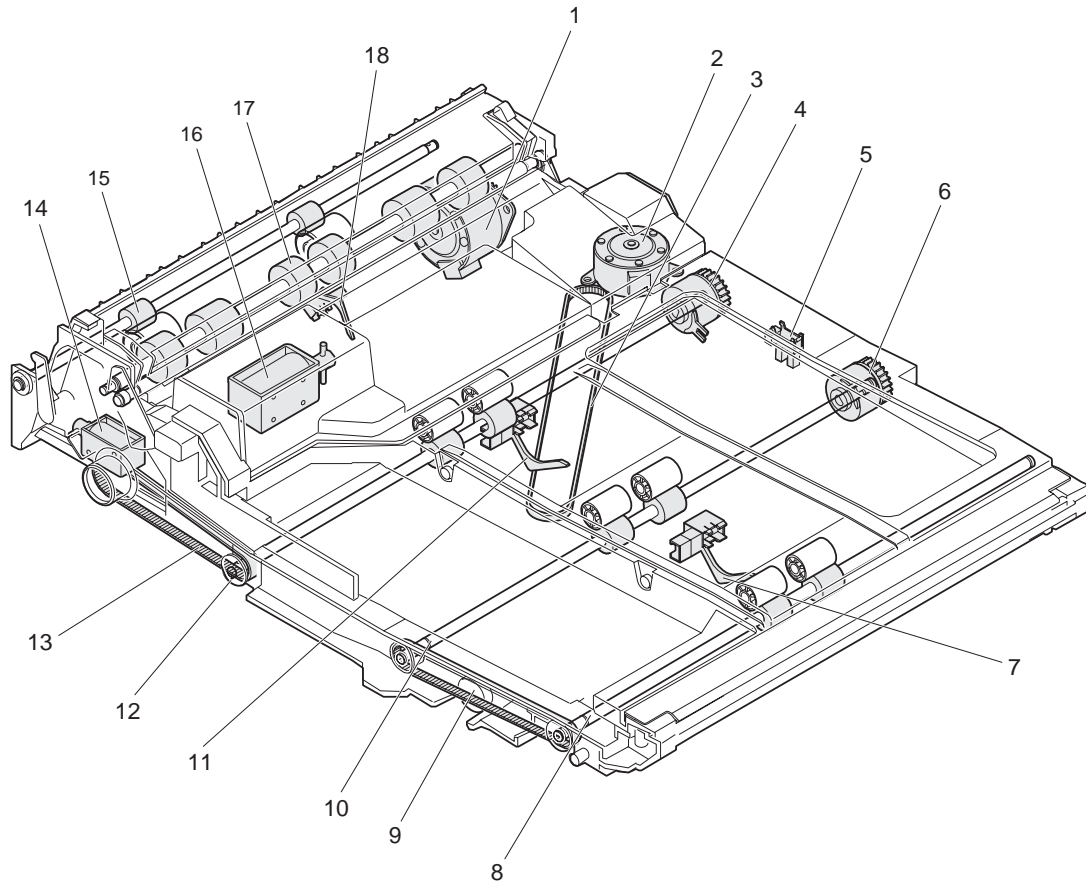

No.	Code	Name	Type	Function and operation
1	—	Reverse motor	Pulse motor	Paper reversion and transport drive
2	—	Alignment motor	Pulse motor	Paper alignment plate drive
3	—	Alignment belt (232MXL)	—	Paper transport
4	DTC1	Transport clutch 1	Electromagnetic clutch	—
5	—	Alignment plate home position detector	Photo transmission	Alignment plate home position detection
6	DTC2	Transport clutch 2	Electromagnetic clutch	—
7	DPPD3	Paper in detector 3	Photo transmission	ADU tray paper in detection
8	—	Transport roller 3	—	ADU tray paper transport
9	—	Transport belt (145MXL)	—	Transport roller drive
10	—	Transport roller 2	—	ADU tray paper transport
11	DPPD2	Paper in detector 2	Photo transmission	ADU tray paper in detection
12	—	Transport roller 1	—	ADU tray paper transport
13	—	Belt B	—	Transport roller drive
14	DSBS	Paper exit/reverse gate solenoid	Solenoid	Selection of paper exit to the lower stage of the 2-tray paper exit unit and the reverse route
15	—	Reverse roller	—	Selection of paper retaining and transport in paper reversion
16	DSCS	Contact/detach solenoid	Solenoid	Selection of paper storing and transport in ADU tray
17	—	Transport roller	—	Paper transport
18	DPPD1	Paper in detector 1	Photo transmission	ADU tray paper in detection

[6] SETTING AND ADJUSTMENTS

1. List of adjustment items

Section	Adjustment item	Adjustment procedure	
A. Process	(1) Developing doctor gap adjustment		
	(2) MG roller main pole position adjustment	MG roller main pole position adjustment	
	(3) Developing bias voltage adjustment	SIM8-1/44-15	
	(4) Main charger grid voltage adjustment	SIM8-2/44-15	
	(5) Transfer charger adjustment	SIM8-6	
	(6) Separation charger bias voltage adjustment	SIM8-7	
	(7) Photoconductor marking sensor sensitivity (gain) adjustment	Image density sensor sensitivity (gain) adjustment	SIM44-2
		Image density sensor sensitivity (gain) adjustment	SIM44-2
(8) Toner concentration adjustment (auto developer adjustment)	SIM25-2		
B. Laser scanner (exposure)	(1) Horizontal image distortion adjustment	LSU lever adjustment	
	(2) Print off-center adjustment	SIM50-10	
	(3) Laser power setting (copier mode)	SIM61-2/44-15 SIM61-4 Printer mode	
C. Scanner	(1) Vertical image distortion balance adjustment	Copy lamp unit installing position adjustment	
	(2) Vertical image distortion balance adjustment	No. 2/No. 3 mirror base installing position adjustment	
	(3) Vertical (sub scanning direction) distortion adjustment [Winding pulley position adjustment]	Winding pulley position adjustment	
	(4) Horizontal (main scanning direction) distortion adjustment [Lower rail height adjustment]	F rail height adjustment	
	(5) Main scanning direction magnification ratio adjustment	CCD unit position adjustment	
	(6) Main scanning direction magnification ratio adjustment	Sub scanning direction magnification ratio adjustment	SIM48-1
		* Including the adjustment with SPF, RSPF	SIM48-1
	(7) Copy image position, image loss, void area adjustment	SIM50-1/2	
	(8) Original off-center adjustment	SIM50-12	
(9) Original off-center adjustment	SIM50-12		
	* Including the adjustment with SPF, RADF, RSPF		

Section	Adjustment item	Adjustment procedure
D. Image density adjustment	(1) Test chart setting	SIM 46-2/9/10/11
E. Paper feed	(1) Manual paper feed size detection level adjustment	SIM40-2
	(2) Paper feed off-center adjustment	
F. Paper transport	(1) Separation pawl operation timing adjustment	SIM51-1
	(2) Paper resist amount adjustment	SIM51-2
G. Others	(1) Original size sensor detection level adjustment	SIM41-2
	(2) Original size sensor detection level adjustment	SIM41-1
	(3) Waste toner full detection level adjustment	
	(4) Touch panel adjustment	SIM65-1
	(5) Key touch sound volume adjustment	Sound volume adjustment
H. SPF	(1) Hinge height check and adjustment	Table glass clearance adjustment
	(2) Open/close sensor position adjustment	SIM 2-02
I. RADF (AR-RF1) (When the RADF is installed)	(1) Document lead edge stop position adjustment	SIM 53-1
	(2) Resist/timing/paper exit sensor adjustment	SIM 53-2
	(3) Test mode with DIP switch	
J. RADF (AR-RF2) (When the RADF is installed)	(1) Document lead edge stop position adjustment	SIM 53-1
	(2) Resist/timing/paper exit sensor adjustment	SIM 53-2
	(3) Test mode with DIP switch	
K. RSPF	Lead edge position adjustment	SIM 50-1/2/6/7
	Magnification ratio adjustment	SIM 48-1
	No. 1 resist quantity adjustment	SIM 51-2
	No. 2 resist quantity adjustment	SIM 51-2
	Image loss adjustment	SIM 50-1/2/6/7
	Center shift adjustment	50-12
	Reflection type sensor adjustment	SIM 53-2
	Image distortion adjustment	Distortion screw adjustment
	Back surface resist adjustment	SB resist plate adjustment
Skew adjustment	Upper/lower guide adjustment	

2. Copier adjustment

A. Process section

(1) Developing doctor gap adjustment

- 1) Remove the screw and the connector which connect the toner hopper and the developing unit, and separate them.
- 2) Loosen the DV doctor fixing screw A.
- 3) Insert a 0.53mm (0.6mm for AR-280/285/335) thickness gauge into the clearance of 40mm ~ 70mm from the DV doctor edge.

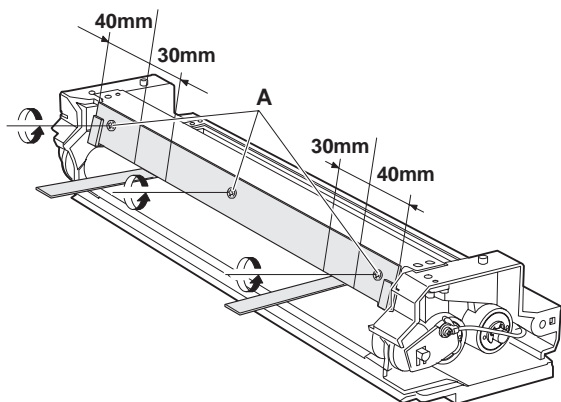

- 4) Press the DV doctor in the arrow direction and tighten the DV doctor fixing screw. (Perform the same procedure for the front and the rear frame.)
- 5) Check that the clearance (2 positions) at 40mm ~ 70mm from the both ends is $0.53 \pm 0.03\text{mm}$ ($0.6 \pm 0.03\text{mm}$ for AR-280/285/335).
 - * When inserting a thickness gauge, be careful not to scratch the DV doctor and the MG roller.

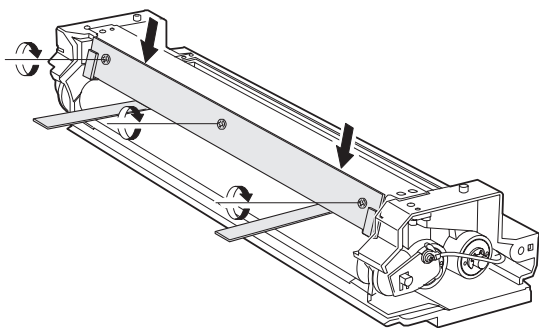

(2) MG roller main pole position adjustment

- 1) Remove the screw and the connector which connect the toner hopper and the developing unit, and separate them. Put the developing unit on a flat floor.
- 2) Tie a needle or pin on a string.
- 3) Hold the string and put the needle horizontally and move it toward the MG roller. (Do not use a clip which is too big to have a correct position since the MG roller diameter is small.)
- 4) With the needle tip at 2 ~ 3 mm apart from the MG roller surface, mark the point on the surface which is on the extended line of the needle tip.
- 5) Measure the distance between the marking position and surface P of the developing unit and check that it is 17mm.

If the distance is not as specified above, loosen the fixing screw of the main pole adjustment plate, and move the adjustment plate to adjust.

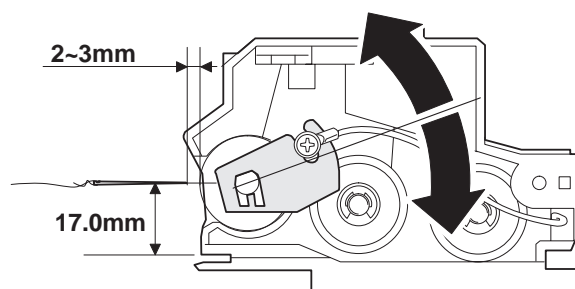
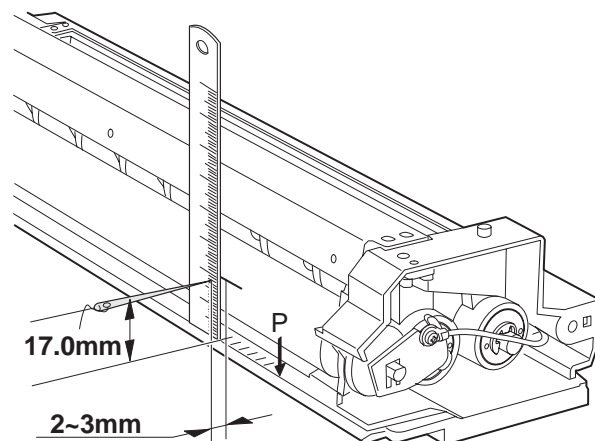

(3) Developing bias voltage adjustment

- 1) Set the digital multi-meter range to the DCV range.
- 2) Put the test probes between the DV bias output check pin (CN2-1 pin) of the high voltage unit and the chassis (GND).

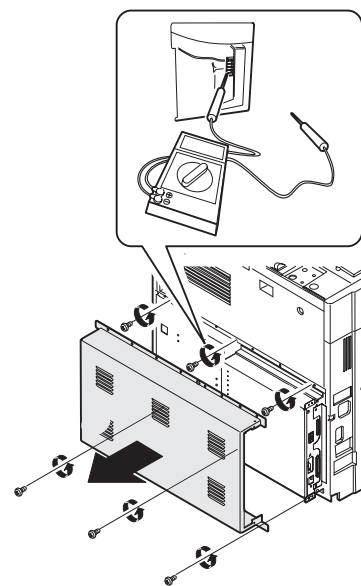

3) Execute SIM 8-1.

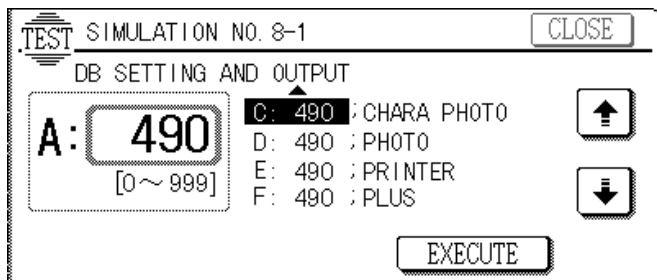
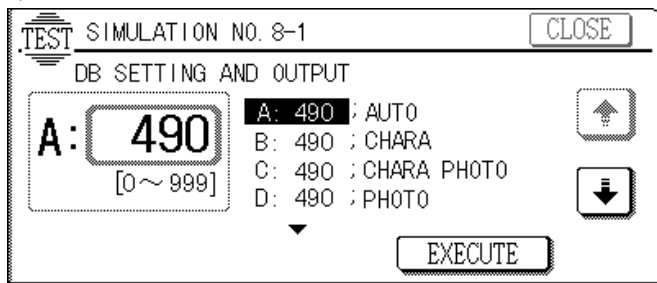

The DV bias can be measured without installing the OPC drum and the developing unit.

4) When the output voltage is within the adjustment range, change the displayed value and adjust. (1 step: about 1 V)

	Adjustment range	
	AR-501/505	Others
Developing negative bias voltage (Auto)	-425 ± 5V	-500 ± 5V
Developing negative bias voltage (Character)	-500 ± 5V	-500 ± 5V
Developing negative bias voltage (Character, Photo)	-500 ± 5V	-500 ± 5V
Developing negative bias voltage (Photo)	-500 ± 5V	-500 ± 5V
Developing bias (Printer)	-500 ± 5V	-500 ± 5V
Developing positive bias voltage	+150 ± 5V	+150 ± 5V

(The value and the output voltage may not coincide.)

(4) Main charger grid voltage adjustment

- 1) Install the DV unit, the drum holder unit, and the charger units to the copier.
- 2) Turn on the main switch, and execute SIM 8-2 to check the grid voltage set value.

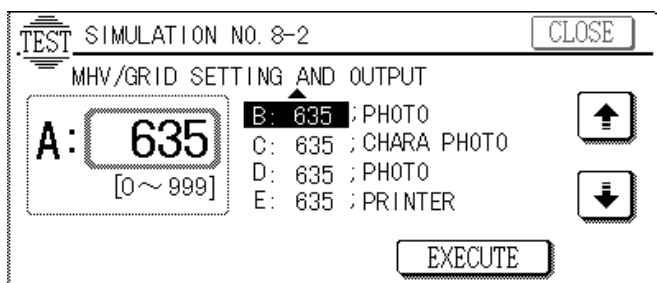
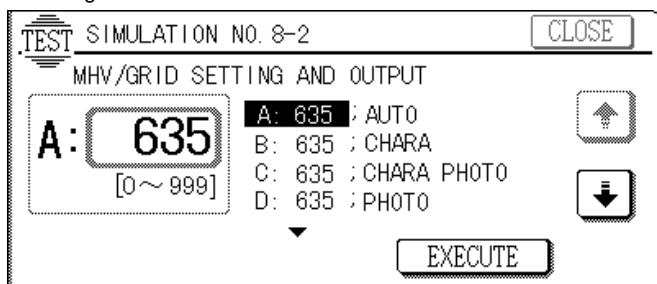

(Measurement at the high voltage PWB check point)

3) Remove the rear cabinet.

- 4) Connect the digital multi-meter to the grid voltage output check pin (CN2-5 pin).
- 5) Set the digital multi-meter range to the DCV range. (Use a digital multi-meter which allows measurement up to DC1000 V.)
- 6) Manually turn on the door switch.
- 7) Turn on the main switch, and execute SIM 8-2 to check.

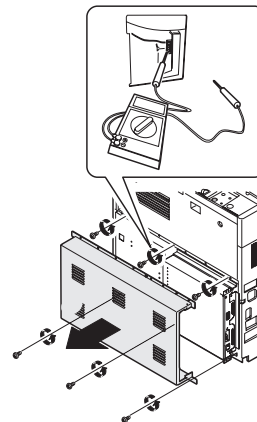

8) If the output voltage is not in the specified range, change the displayed value and adjust. (1 step: about 1V)

	Adjustment range		
	AR-280/285/335	AR-250/281/286/336/405	AR-501/505
Grid voltage (Auto)	-642 ± 5V	-602 ± 5V	-570 ± 5V
Grid voltage (Character)	-642 ± 5V	-602 ± 5V	-645 ± 5V
Grid voltage (Character, Photo)	-642 ± 5V	-602 ± 5V	-645 ± 5V
Grid voltage (Photo)	-642 ± 5V	-602 ± 5V	-645 ± 5V
Grid voltage (Printer)	-642 ± 5V	-602 ± 5V	-645 ± 5V
Grid voltage (FAX)	-642 ± 5V	-602 ± 5V	-645 ± 5V

(The value and the output may not coincide.)

(5) Transfer charger current adjustment

a. Special measurement tool

Electrode sheet (UKOG-0110FCZZ)

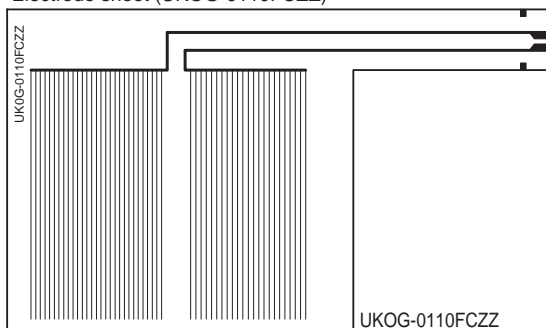

Electrode sheet harness (DHAI-0304FCZZ)

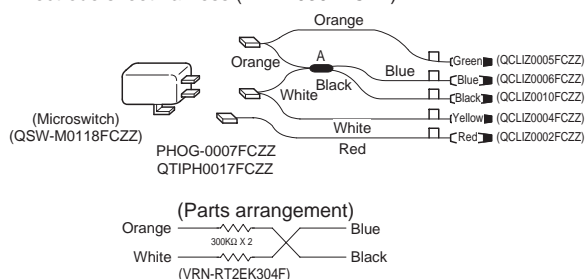

b. Adjustment procedure

- 1) Remove the developing unit, the transfer/separation charger unit, and the main charger unit from the copier.
- 2) Remove the process unit from the copier.
- 3) Remove the OPC drum from the process unit, and install the electrode sheet by using a rubber band, tape, etc.
- 4) Install the OPC drum with the electrode sheet installed to the process unit, and install the process unit to the copier.
- 5) Install the drum holder unit to the copier so that the electrode sheet lead wire can be taken out from the developing unit side.

AR-280/285/335

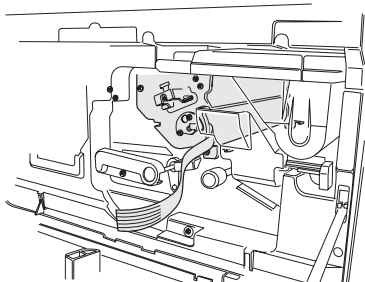
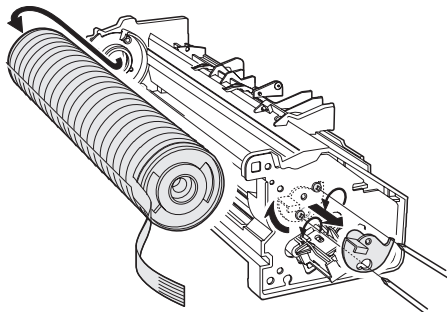

AR-250/281/286/336/405/501/505

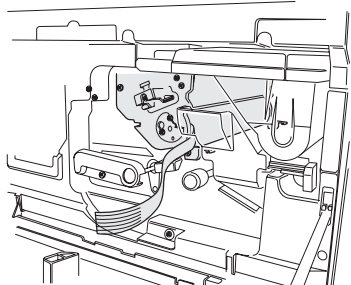
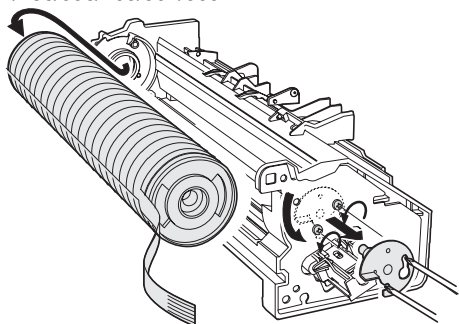

- 6) Clean the transfer charger wire separation lamp and install the transfer/separation charger unit to the copier.

If necessary, wipe the lamp which can be seen from the square hole of the TC guide rail with waste cloth.

(Do not install the main charger unit.)

- 7) Connect the electrode sheet and the digital multi-meter (or an ammeter). Manually turn on the door switch.

- 8) Check the drum current on the front frame side and the rear frame side.

The current on the front and the rear frame sides: within 6.0 μ A

- Turn on the main switch, and execute SIM 8-6.

(THVG will be turned ON for about 30 sec.)

- Measure the drum current on the front frame side and the rear frame side.
 - When the microswitch is OFF, the drum current on the front frame side is displayed.
 - When the microswitch is ON, the drum current on the rear frame side is displayed.

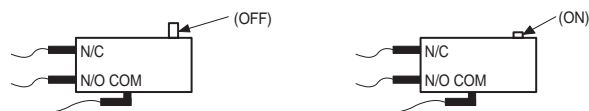

- Check that the current on the front and the rear frame side is 6.0 μ A or less.

If the current is greater than 6.0 μ A, replace the charger unit with new one.

- 9) Adjust THVG output current.

- Turn on the main switch and execute SIM 8-6.

AR-280/285/335

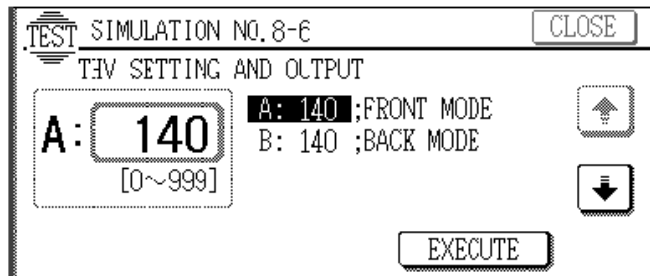

AR-250/281/286/336/405

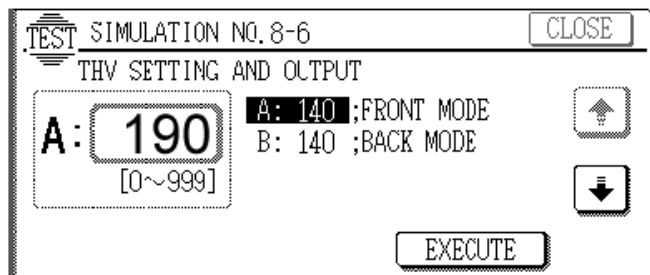

AR-501/505

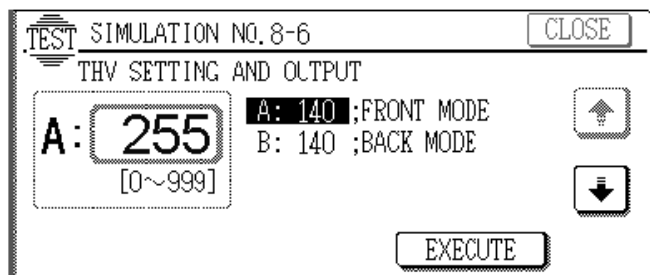

(THVG will be turned on for about 30 sec.)

- If the output current is not in the specified range, change the displayed value and adjust. (1 step: about 0.1 μA)

Transfer charger current	Adjustment spec		
	AR-250/280/281/285/286/335/336	AR-405	AR-501/505
TC drum current (Front surface mode)	+13.5+1.5μA	+15.0+1.5μA	+18.0+1.5μA
TC drum current (Back surface mode)	+13.5+1.5μA	+15.0+1.5μA	+18.0+1.5μA

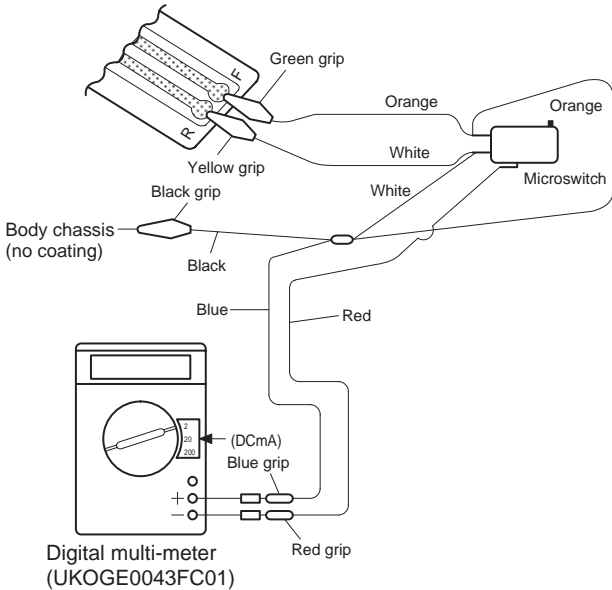

* Check that the black clip is securely grounded to the machine chassis.

When UKOGE0043CS01 is used:

- Knob 1: Set to DCmA.
- Knob 1: Connect to 2.
- Red clip: Connect to (+).
- Blue clip: Connect to (-).

When an ammeter is used:

- Red clip: Connect to (+) of the ammeter.
- Blue clip: Connect to (-) of the ammeter.

(6) Separation charger DC component voltage

- 1) Install the DV unit, the drum holder unit, and the charger units to the copier.
- 2) Remove the rear cabinet.
- 3) Connect the digital multi-meter to SHVG output check pin (CN2-3 pin).
- 4) Set the digital multi-meter range to the DCV range.
- 5) Manually turn on the door switch.
- 6) Execute SIM 8-7. (SHVG will be turned on for about 30 sec.)

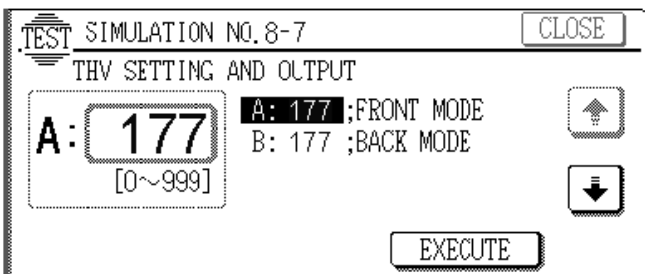

- 7) If the output voltage is not in the specified range, change the displayed value and adjust. (1 step: about 1V)

	Adjustment range		
	AR-250/280/281/285/286/335/336	AR-405	AR-501/505
Separation DC component voltage (Front surface mode)	-140 ± 10V	-150 ± 10V	-200 ± 10V
Separation DC component voltage (Back surface mode)	-140 ± 10V	-150 ± 10V	-200 ± 10V

(7) OPC drum marking sensor/Image density sensor gain adjustment

This adjustment must be performed in the following cases:

- When both sensors are cleaned in maintenance.
- When the value of DMLED/PCLED in SIM 44-12 are greater than about 100.
Clean both sensors and perform the adjustment.

- 1) Execute SIM 44-2.

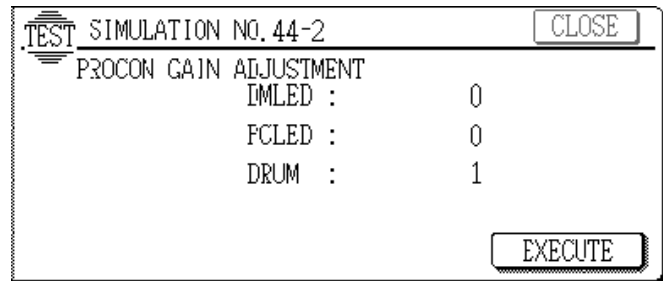

- 2) When the adjustment is completed, the gain value is displayed. If an error occurs during the adjustment, the error display is made.

(8) Toner density adjustment (Auto developer adjustment)

This adjustment must be performed in the following case:

- When new developer is supplied.

- 1) Execute SIM 25-2.

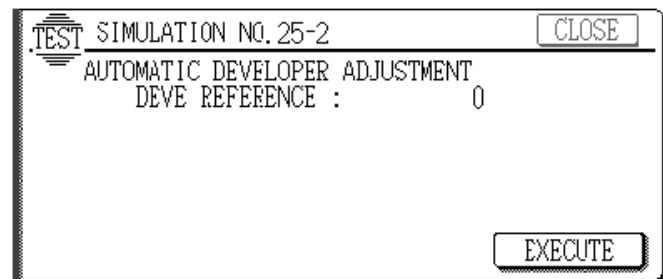

- 2) The adjustment is automatically made with the toner density sensor output value displayed. After 3 minutes from starting stirring, the toner density sensor is sampled 16 times, and the average value is stored as the toner density adjustment value.

* When new developer is supplied, clear the developer counter with SIM 24-5.

B. Laser scanner section

(1) Horizontal image distortion adjustment

1) Execute SIM 64-1, and print the pattern of SQUARE from the manual feed tray.

(A: 22 E: 1)

TEST SIMULATION NO. 64-1		CLOSE
SELF PRINT		
A: <input type="text" value="29"/>	A: 29 ;PRINT PATTERN	↑
[1~29]	B: 255 ;DENSITY	↓
	C: 1 ;MULTI COUNT	
	D: 1 ;EXPOSURE	
EXECUTE		

TEST SIMULATION NO. 64-1		CLOSE
SELF PRINT		
F: <input type="text" value="1"/>	C: 1 ;MULTI COUNT	↑
[1~2]	D: 1 ;EXPOSURE	↓
	E: 1 ;PAPER SELECT	
	F: 1 ;DUPLEX	
EXECUTE		

- Set items
- A: Self print pattern
- B: Density level
- C: Setting of the number of self print sheets
- D: Density mode
- | | |
|--------|--------------|
| 1 Auto | 3 Text/Photo |
| 2 Text | 4 Photo |
- E: Cassette selection
- | | |
|-----------------------|------------------------|
| 1 Manual feed | 5 Desk middle cassette |
| 2 Upper cassette | 6 Desk lower cassette |
| 3 Lower cassette | 7 LCC |
| 4 Desk upper cassette | |
- F: Duplex print selection
- | | |
|-----------|----------|
| 1 Simplex | 2 Duplex |
|-----------|----------|

2) Obtain value a of the printed sheet.

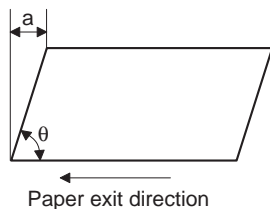

3) Turn the adjustment handle to adjust according to the value a.

AR-280/285/335

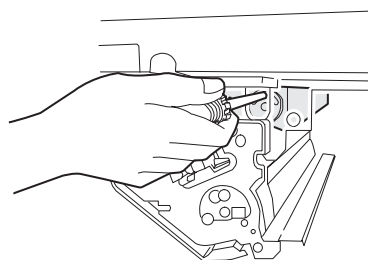

AR-250/281/286/336/
405/501/505

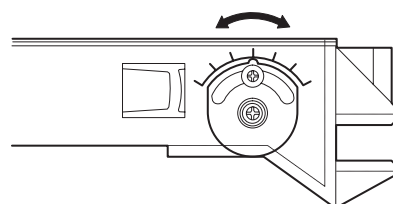
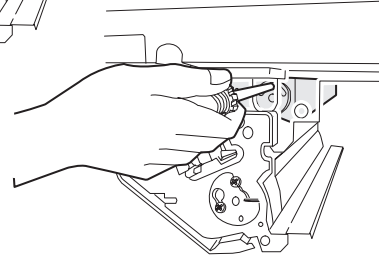

Adjustment handle:	1 scale = 0.5mm (dimension a)
q<90 degrees:	Right direction
q>90 degrees:	Left direction
Adjustment specification:	a = 0 mm, θ = 90 degrees

(2) Print off-center adjustment

1) Execute SIM 64-1. print one sheet from each paper feed port.

Measure the void amount both sides.

When making duplex copy with OC, press the [CLOSE] key to enter the copy menu and read two pages of documents. Then press the [READ CORRECT] key.

* Select the self print pattern which allows easy measurement of the void amount.

2) Execute SIM 50-10.

TEST SIMULATION NO. 50-10		CLOSE
PRINT OFF-CENTER ADJUSTMENT		
A: <input type="text" value="50"/>	A: 50 ;Manual	↑
[0~99]	B: 50 ;1CS	↓
	C: 50 ;2CS	
	D: 50 ;ADU	
	E: 50 ;DESK 1CS	OK

TEST SIMULATION NO. 50-10		CLOSE
PRINT OFF-CENTER ADJUSTMENT		
H: <input type="text" value="50"/>	D: 50 ;ADU	↑
[0~99]	E: 50 ;DESK 1CS	↓
	F: 50 ;DESK 2CS	
	G: 50 ;DESK 3CS	
	H: 50 ;LCC	OK

3) Change each value to adjust so that the void amounts of both sides are even.

a > b: Increase the value.

a < b: Decrease the value. (See the figure below.)

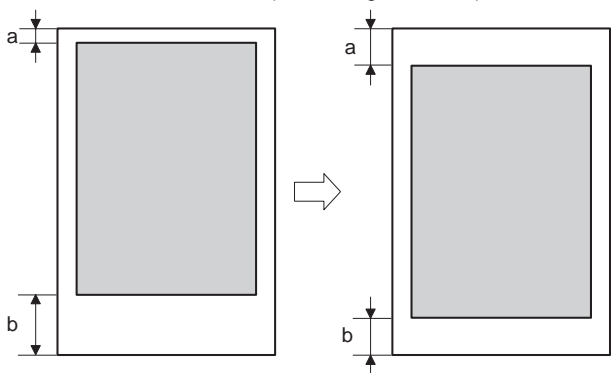

4) Press the CA key to terminate the simulation.

(3) Laser power setting

* Normally the laser power is automatically corrected by process control. Use the image density adjustment described later unless there is a special request from the user.

(AR-280/285/335)

All must be set to "16".

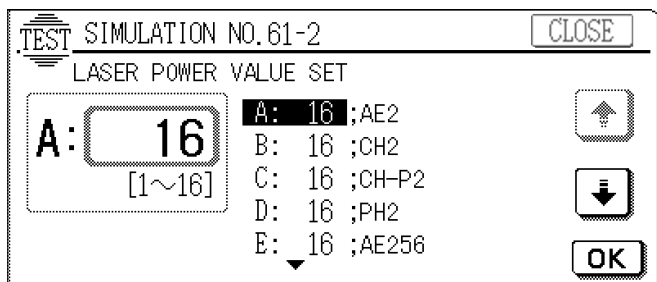

(AR-250/281/286/336)

All must be set to "7".

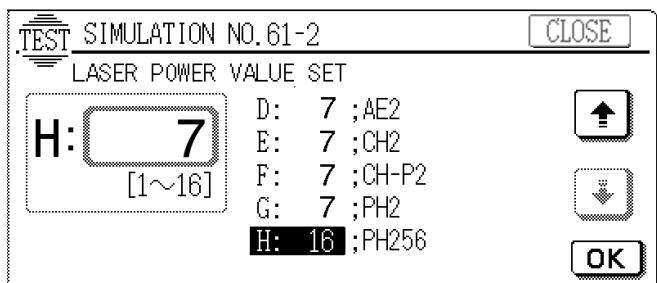

(AR-405)

Set all to "5" except for PH256.

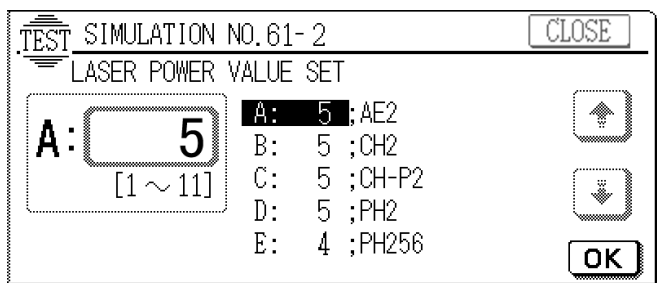

(AR-501/505)

All must be set to "5".

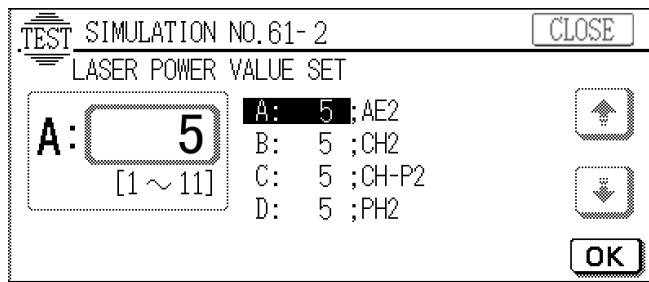

C. Scanner section

(1) Vertical image distortion balance adjustment (Copy lamp unit installing position adjustment)

1) Insert the front/rear mirror base drive wire into the frame groove and press and fix it with the wire fixing plate. At that time, do not tighten the wire fixing screw.

Change the direction of the lamp positioning plate. (F and R)

2) Push the copy lamp unit onto the positioning plate, and tighten the wire fixing screw.

AR-280/285/335

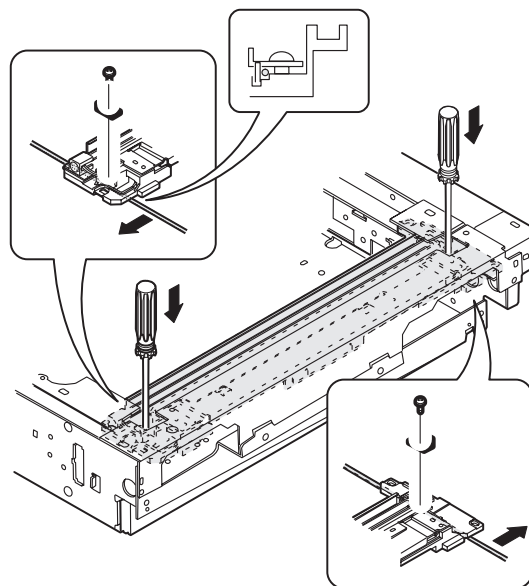
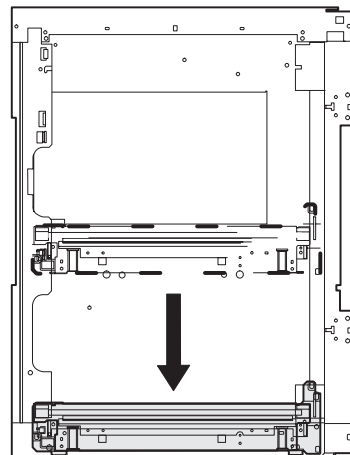

AR-250/281/286/336/405/501/505

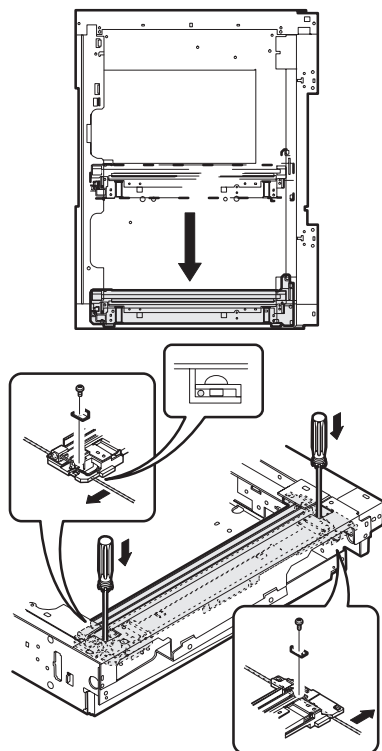

* Note for assembling the copy lamp unit

Move the copy lamp unit to the paper exit side, and fix the copy lamp unit with the harness guide so that the distance between the copy lamp harness and the lower frame is about $24\pm 2\text{mm}$, (25 ~ 30mm) with the copy lamp harness extended.

After fixing, manually shift the copy lamp unit a few times to check that it moves smoothly.

If the copy lamp harness is loosely fixed, the copy lamp unit may jump up when reading, resulting in abnormal reading.

AR-280/285/335

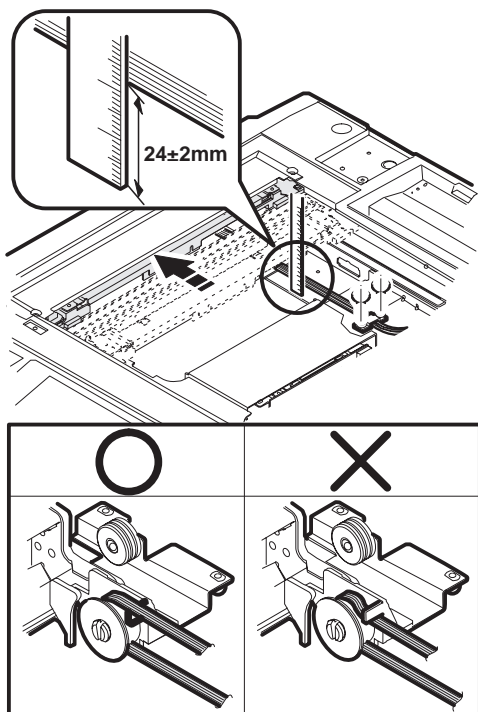

AR-250/281/286/336/405/501/505

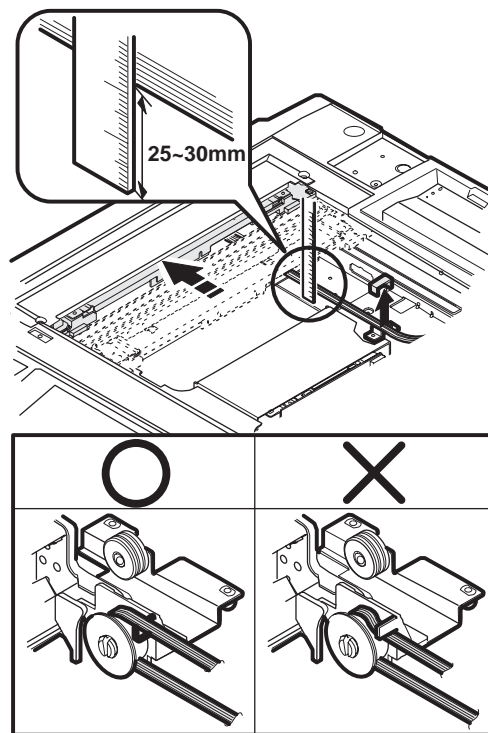
(2) Vertical image distortion balance adjustment
(No. 2/3 mirror base unit installing position adjustment)

This adjustment is to adjust the parallelism of the mirror base to the OPC drum surface and the original surface.

- 1) Manually turn the mirror base drive pulley to bring mirror base B into contact with mirror base positioning plate.

If, at that time, the front frame side and the frame side of mirror base B are brought into contact with the mirror base positioning plate simultaneously, the parallelism is correct and there is no need for adjustment.

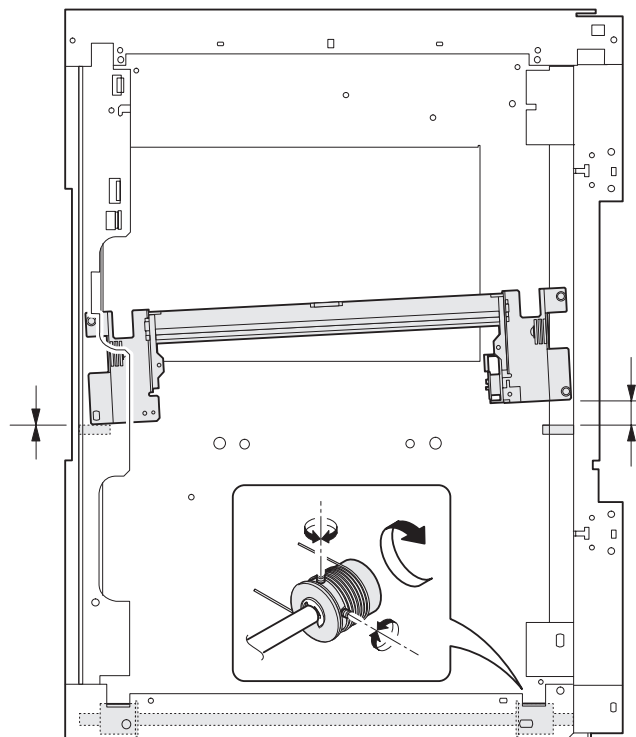

Illust: AR-280

(3) Vertical (sub scanning direction) distortion adjustment [Winding pulley position adjustment]

This adjustment is executed in the following cases:

- When the mirror base drive wire is replaced.
- When the lamp unit, or No. 2/3 mirror holder is replaced.
- When a copy shown below is made.

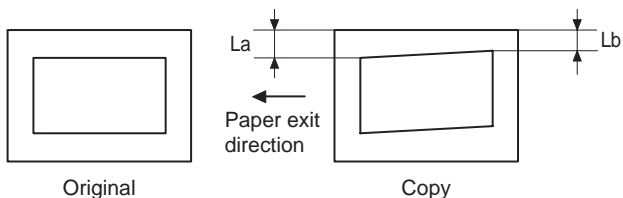

1) Set A3 white paper on the original table as shown below.

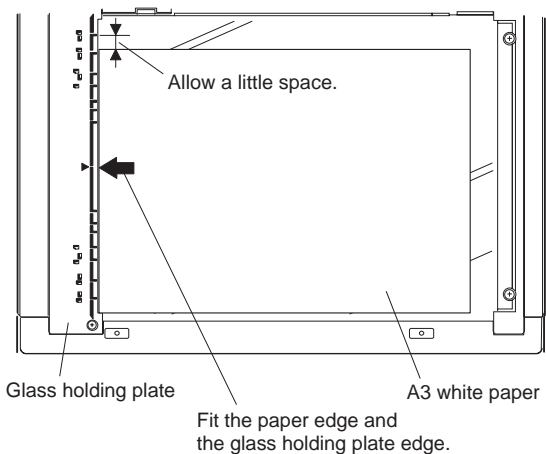

illust: AR-280

- 2) With the original cover open, make a normal (X 1.0) copy.
- 3) Measure the black distance at the lead edge and the rear edge of the copy paper.

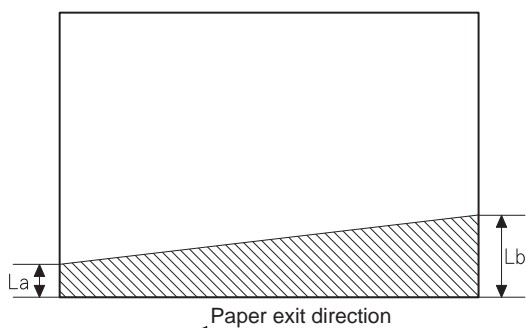

La: Lead edge black background section
Lb: Rear edge black background section

If $La = Lb$, the procedures 4) through 7) are not required.

4) Loosen the fixing screw of the front or the rear frame mirror base drive pulley.

- If $La < Lb$, turn the rear frame mirror base drive pulley in direction B. (Do not move the mirror base drive pulley shaft.)
- If $La > Lb$, turn the rear frame mirror base drive pulley in direction A. (Do not move the mirror base drive pulley shaft.)

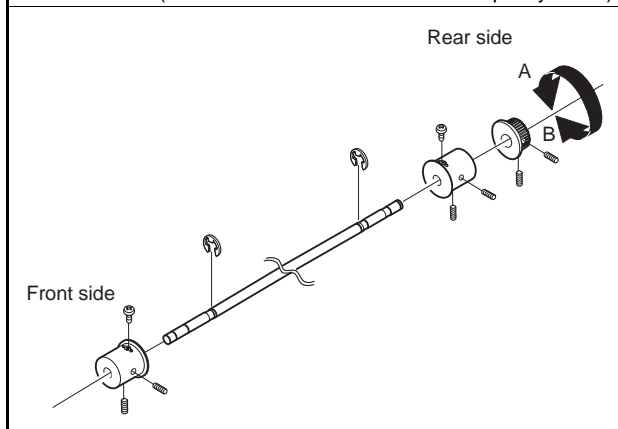

- 5) Tighten the fixing screw of the mirror base drive pulley.
- 6) Perform procedures 1) through 3).
- 7) If La is not equal to Lb , perform procedures 4) and 5).
If $La = Lb$, the adjustment is completed.
Repeat procedures 1) through 6) until $La = Lb$.

(4) Horizontal (main scanning direction) distortion adjustment [Lower rail height adjustment]

When there is no distortion in the direction of mirror base scanning and there is sub scanning direction distortion, it can be adjusted by changing the No. 2/3 mirror base unit rail height.

- Before this adjustment, perform the horizontal image distortion adjustment in the laser scanner section.

This adjustment must be performed in the following cases:

- When the mirror base wire is replaced.
- When the copy lamp unit and no. 2/3 mirror unit are replaced.
- When the mirror unit rail is replaced and moved.
- When a copy shown below is made.

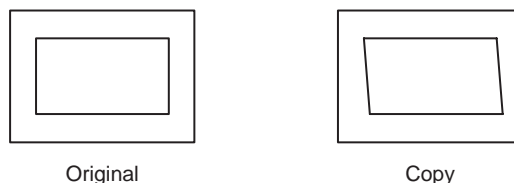

1) Make an original for the adjustment.

Draw parallel lines at 10mm from both sides of an A3 white paper.

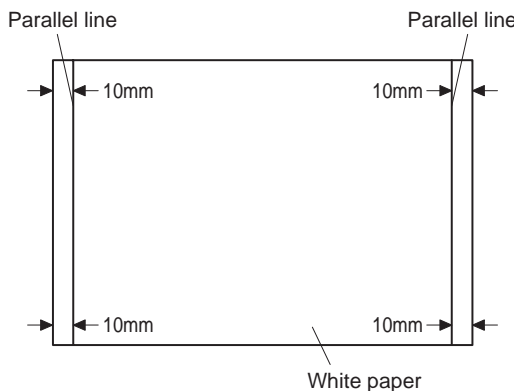

illust: AR-280

- 2) Make a copy of the adjustment original on an A3 white paper at the normal magnification ratio.

(Fit the paper edge and the glass holding plate edge.)

- 3) Measure the distances between the lines and the corners (4 positions of La, Lb, Lc, Ld).

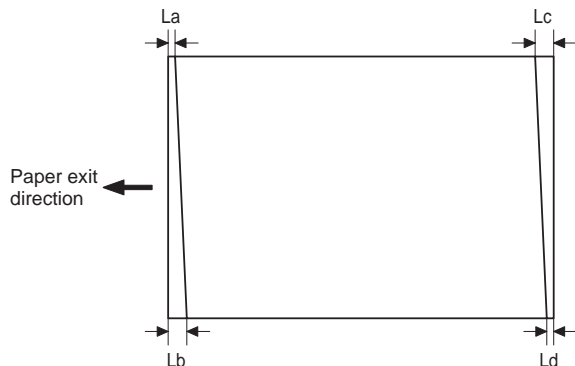

When $L_a = L_b$ and $L_c = L_d$, no need to adjust.

When $L_a = L_b = L_c = L_d$, there is no need for adjustment.

- 4) Move the mirror base B rail position up and down (in the arrow direction) to adjust.

- When $L_a > L_b$, move the mirror base B rail on the paper exit side upward by the half of the difference of $L_a - L_b$.
- When $L_a < L_b$, move the mirror base B rail on the paper exit side downward by the half of the difference of $L_b - L_a$.
Example: When $L_a = 12\text{mm}$ and $L_b = 9\text{mm}$, move the mirror base B rail on the paper exit side 1.5mm upward.
- When $L_c > L_d$, move the mirror base B on the paper feed side downward.
- When $L_c < L_d$, move the mirror base B on the paper feed side upward.
- * When moving the mirror base rail, hold the mirror base rail handle.

- 5) Adjust so that $L_a = L_b$ and $L_c = L_d$.
- 6) After completion of the adjustment, manually turn the mirror base drive pulley to make full scanning of mirror base A and mirror base B and check that they do not make contact.
- * If the mirror base rail is moved extremely, the mirror base may be brought into contact. Be careful of that.

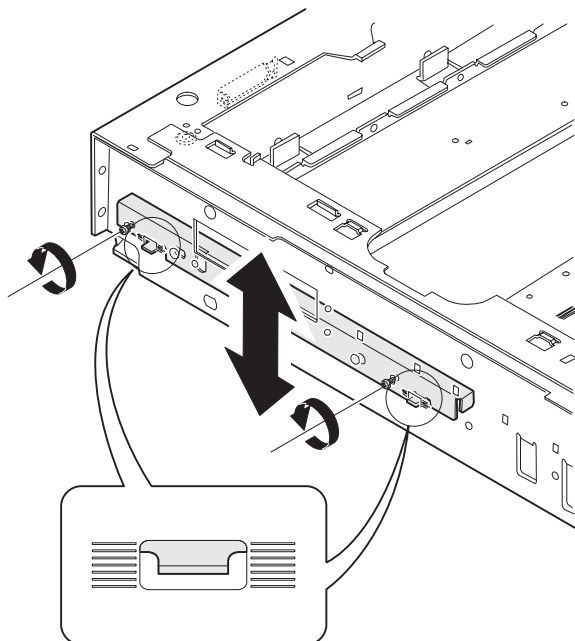

illustr: AR-280

(5) Main scanning direction magnification ratio adjustment (CCD unit installing position adjustment)

- 1) Execute SIM 48-1.
- 2) Set each value to 50 (initial value).
- 3) As shown in the figure below, put a scale on the original table.

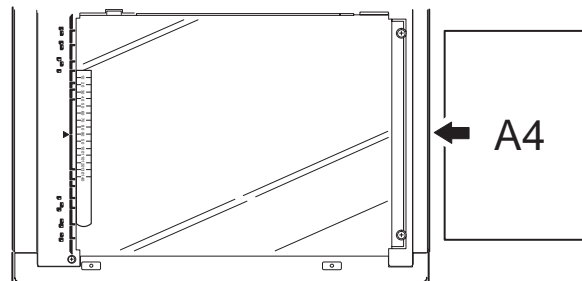

illustr: AR-280

- 4) make a normal copy on A4 paper.
- 5) Compare the scale image length and the actual scale length.
- 6) Obtain the main scanning direction copy magnification ratio according to the following formula.

Main scanning direction copy magnification ratio

$$= \frac{(\text{Original length} - \text{Copy length})}{\text{Original length}} \times 100\%$$

(Example) Put the scale so that 50mm of the scale is at the center of the original.

Main scanning direction copy magnification ratio

$$= \frac{100 - 98}{100} \times 100 = 2$$

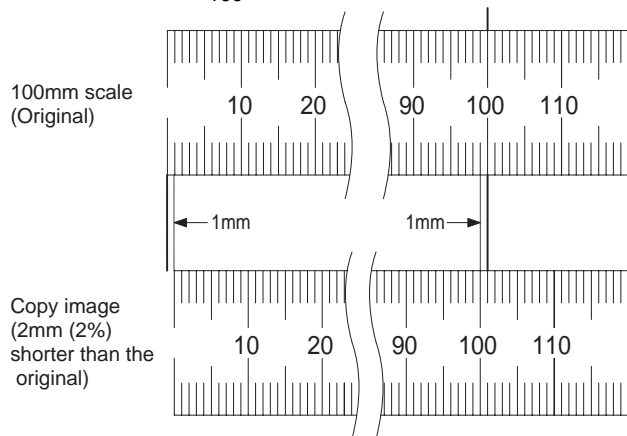

- 7) Remove the original guide L and R, and remove the table glass.
- 8) Remove the dark box cover.
- 9) Remove the slide pin of the front cover unit.

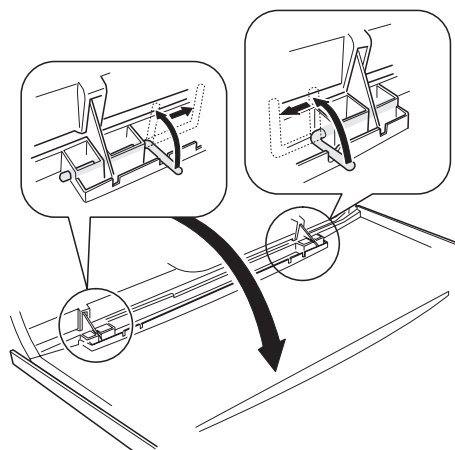

- 10) Insert the slide pin as shown below and make positioning in the vertical direction.

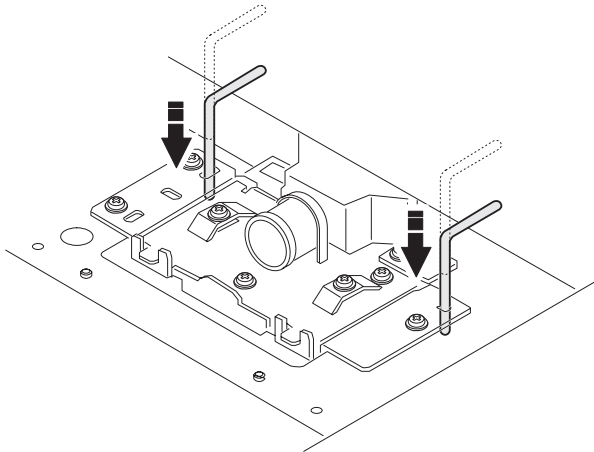

- 11) Insert the slide pin as shown below and make positioning in the horizontal direction.

(Initial position positioning is completed.)

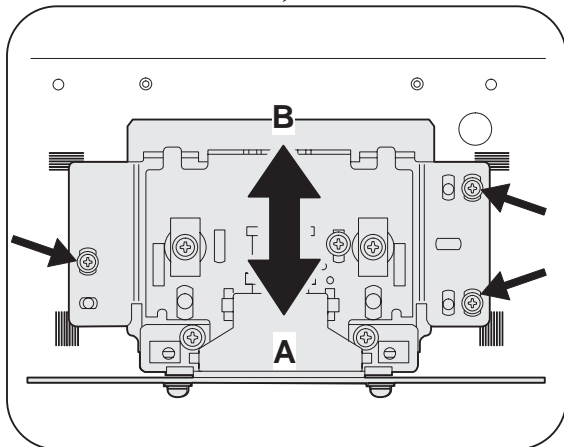
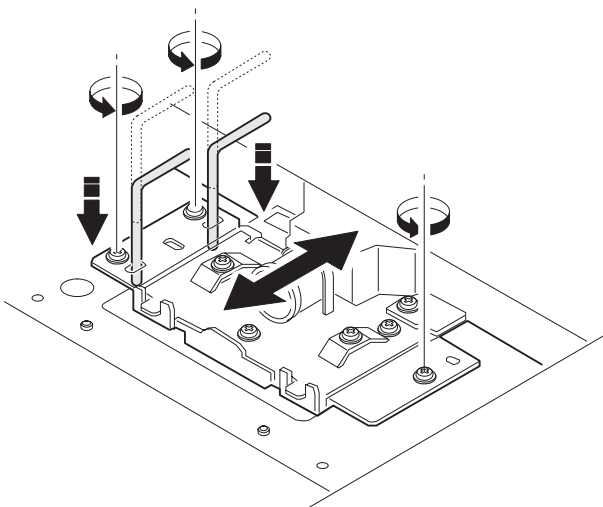

Never loosen a screw other than these ones.

- * Never loosen the screws which are not indicated in the figure. If loosened, the adjustment cannot be made and the unit must be replaced.
- 12) Make a sample copy in the initial position and measure the magnification ratio again.
- 13) Change the installing position in the horizontal direction to adjust the magnification ratio.

- When the copy image is longer than the original, move in the direction of B.
- When the copy image is shorter than the original, move in the direction of A.
- One scale of scribe line corresponds to 0.2%.
- For fine errors which cannot be adjusted with this adjustment, use the next simulation SIM 48-1.

(6) Main/sub scanning direction magnification ratio adjustment

- 1) Before this adjustment, perform the previous adjustment of CCD unit installation position.
- 2) Place a scale on the original table as shown. (Scale a and scale b may be placed together or individually.)
 - After warming up, the ready lamp lights up.
 - The current set value is displayed simultaneously. (0 ~ 20)

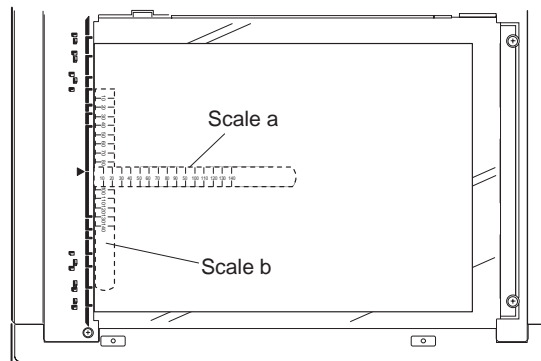

illust: AR-280

- 3) Make a normal copy and obtain the main/sub scanning direction magnification ratios.

Copy magnification ratio (MRCP)

$$= \frac{(\text{Original dimension} - \text{Copy dimension})}{\text{Original dimension}} \times 100\%$$

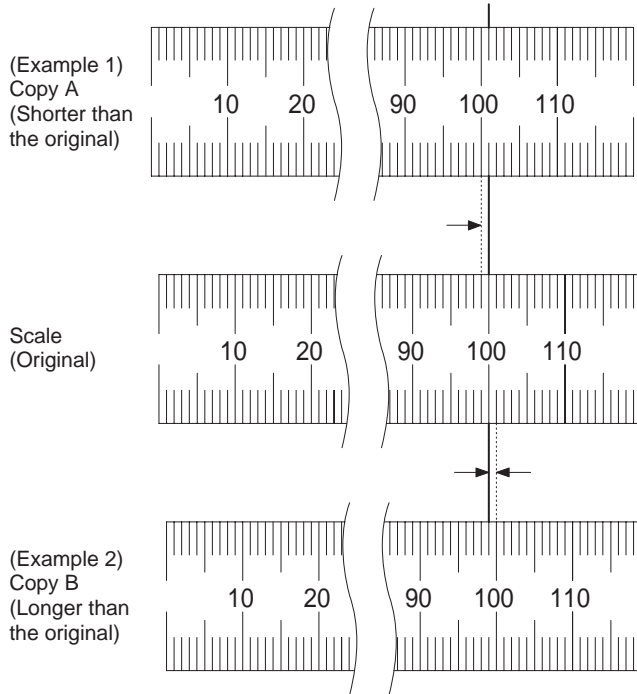

4) Execute SIM 48-1.

(AR-501/505)

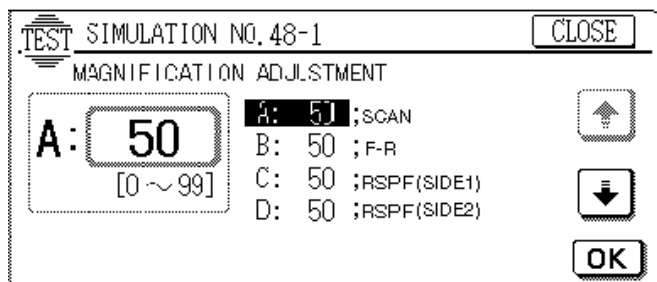

(Other models)

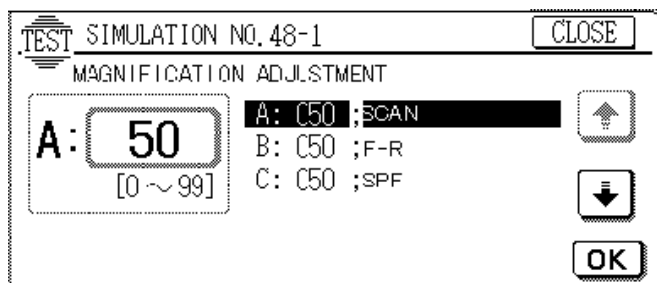

5) Change value A so that the magnification ratio in the sub scanning direction is within the specified range.

6) Change value B so that the magnification ratio in the main scanning direction is within the specified range.

- Adjustment specification: Within $\pm 0.8\%$
 - When the copy dimension is smaller than the original
 - ↓
 - Make the value greater.
 - When the copy dimension is greater than the original
 - ↓
 - Make the value smaller.
- When the value is changed by one step, the ratio is changed by about 0.1%.

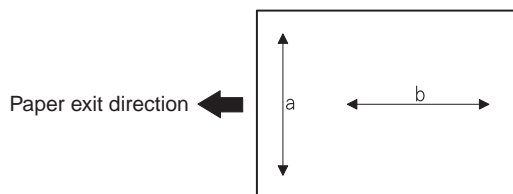

a → Magnification ratio in the main scanning direction
b → Magnification ratio in the sub scanning direction

[AR-280/281 only]

- 7) Make a copy of A3 original with SPF, and measure the magnification ratio in the sub scanning direction.
- 8) Change value C so that the magnification ratio in the sub scanning direction is within the specified range.
- 9) Press the CA key to cancel the simulation.

(7) Copy image position, image loss, void area adjustment

Before performing this adjustment, check that SIM 50-5 is set to 50. If not, set it to 50.

This adjustment uses SIM 50-2 and SIM 50-1.

The above two simulations are used in the following manner.

Sim 50-2: Rough adjustment

SIM 50-1: Fine adjustment

If the desired value is obtained by SIM 50-2, there is no need to perform SIM 50-1.

(Adjustment items)

No.	Adjustment item	Operation mode		SIM 50-2 set item	SIM 50-1 set item	Adjustment value	Note
1	Lead edge image loss	Document table mode	SPF mode	IMAGE LOSS	IMAGE LOSS	1.5 to 3.0 mm	
2	Lead edge void area	Document table mode	SPF mode	DEN-A	DEN-A	1.5 to 3.0 mm	
3	Rear edge image loss		SPF mode	REAR LOSS (SPF)	REAR LOSS (SPF)	1.5 to 3.0 mm	AR-4XX series only
4	Rear edge void area	Document table mode	SPF mode	DEN-B	DEN-B		
5	Image reference position	Document table mode			RRC-A		
6	Paper timing	Document table mode	SPF mode		RRC-B		
7	Image reference position		SPF mode		SPF		
8	Distance between image lead edge position and scale of 10mm × 10	Document table mode		L1			
9	Distance between paper lead edge and image lead edge × 10	Document table mode		L2			
10	Distance between image lead edge position x scale of 10mm × 10		SPF mode	L3			

Adjustment items 1 ~ 4 can be adjusted either with SIM 50-1 or SIM 50-2.

The adjustment values of items 8 ~ 10 will affect the adjustment items 5 ~ 7 automatically.

Therefore, adjusting the items 8 ~ 10 will lead to the same result as adjusting the items 5 ~ 7.

- 1) Place a scale on the document table as shown below, and make a normal (100%) copy.

Note that the scale must be placed in parallel to the scanning direction and that the scale lead edge must be clearly copied.

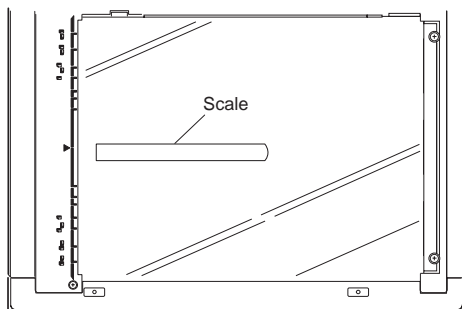

illustr: AR-280

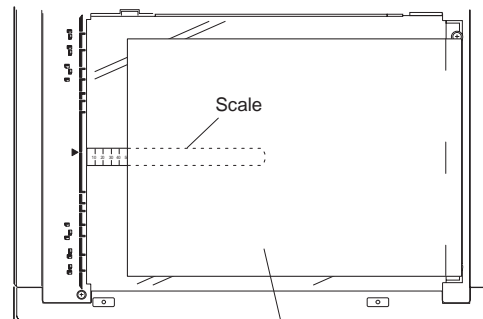

Paper (White paper)

illustr: AR-280

- 2) Process the copied paper as shown below.

Cut the copied paper along the line at the edge of the scale image. The cut line and the scale image must form a right angle (90 degrees).

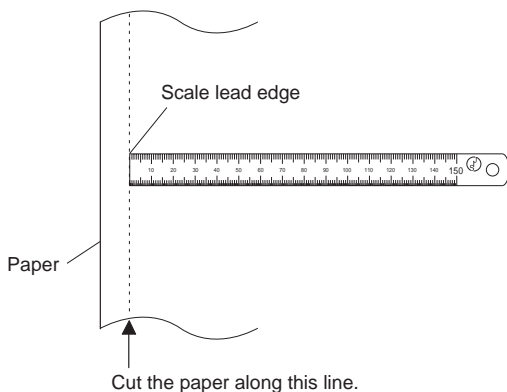

- 3) Place the scale on the document table as shown below.

Note that the scale must be placed in parallel to the scanning direction and that the scale lead edge is in close contact with the document guide plate.

- 4) Enter the SIM 50-2 mode.
- 5) Set the image loss and DEN-A set values to "0."
- 6) Set all the values of L1, L2, and L3 to "0."
- 7) Make a copy at 400%. (Document table mode)
- 8) Measure dimensions X and Y of the copied scale image.

X: Distance between the copy image lead edge and the scale of 10mm

Y: Distance between the paper lead edge and the copy image lead edge

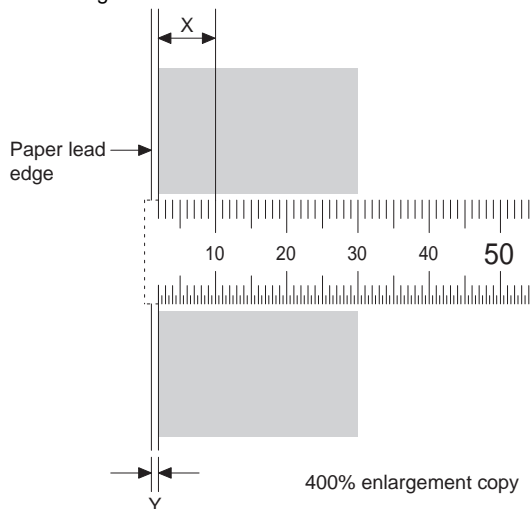

- 9) Set the document as in procedure 1) and 2) on the SPF, and make a copy at 200% in the SPF mode.
- 10) Measure the dimension L3 of the copied scale image.

Z: Distance between the copy image lead edge and the scale of 10mm

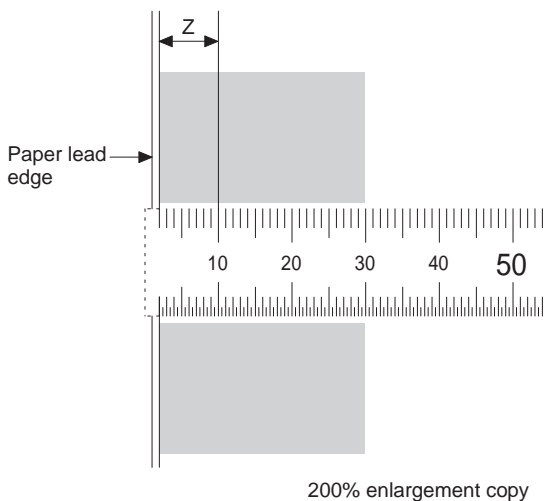

- 11) Enter L1, L2, and L3 as follows:

$$L1 = X \times 10$$

$$L2 = Y \times 10$$

$$L3 = Z \times 10$$

- 12) Cancel the simulation mode, make a copy in the document table mode and in the SPF mode, and check that the lead edge image loss and the void area are in the specified range as shown below:

Lead edge image loss: 1.5 ~ 3.0mm

Lead edge void area: 1.5 ~ 3.0mm

If the above condition is not satisfied.

- 13) Enter the SIM 50-1 mode.

- 14) Set the scale on the document table in the same manner as in procedure 3). Make a copy at 50% and at 400% in the document table mode.
- 15) Measure the distance between the paper lead edge and the copy image lead edge of 50% copy and 400% copy.
- 16) Check that there is no difference between the measured distance of 50% copy and that of 400% copy.

If the difference is more than 1.5mm, change and adjust the RRC-A value.

Repeat procedures 12) to 16) until the above condition is satisfied.

- 17) Use the document made in procedures 1) and 2) and make a copy at 50% and at 400% in the SPF mode.
- 18) Measure the distance between the paper lead edge and the copy image lead edge of 50% copy and that of 400% copy.
- 19) Check that there is no difference between the above measured distance of 50% copy and that of 400% copy.

If the difference between the distances is more than 1.5mm, change and adjust the SPF value.

Repeat procedures 17) and 18) until the above condition is satisfied.

- 20) If the lead edge void area is outside the specified range, change the DEN-A value.
- 21) If the lead edge image loss is outside the specified range, change the IMAGE LOSS value.
- 22) If the rear edge void area is outside the specified range, change the DEN-B value.
- 23) If the rear edge void area is outside the specified range, change the REAR LOSS (SPF) value.

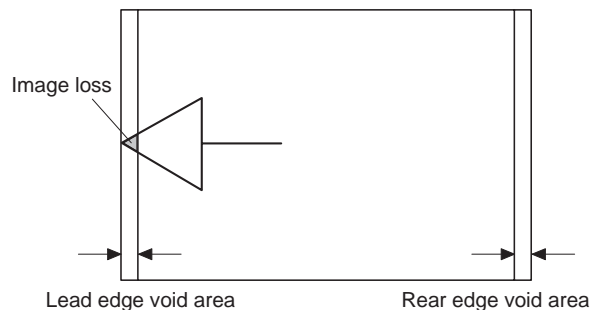
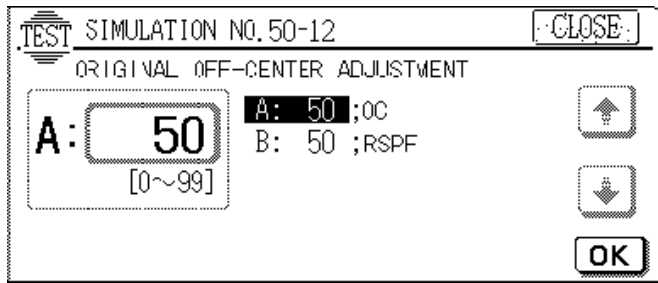

IMAGE LOSS	Lead edge image loss	1.5 to 3.0 mm	The greater the set value is, the greater the image loss is.
DEN-A	Lead edge void area	1.5 to 3.0 mm	The greater the set value is, the greater the void area is.
DEN-B	Rear edge void area	1.5 to 3.0 mm	The greater the set value is, the greater the void area is.
REAR LOSS	Rear edge image loss	1.5 to 3.0 mm	The greater the set value is, the greater the image loss is.

(8) Original off-center adjustment

- 1) Place the reference original for the off-center adjustment on the original table.
- 2) Execute SIM 50-12.

(AR-501/505)



(Other models)

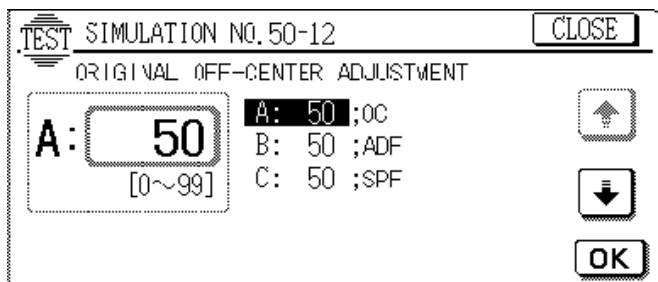

- 3) Press the PRINT button after lighting the RPL, and a copy will be made. If the arrow image on the copy paper is shifted from the center line as shown below, change the set value and adjust.

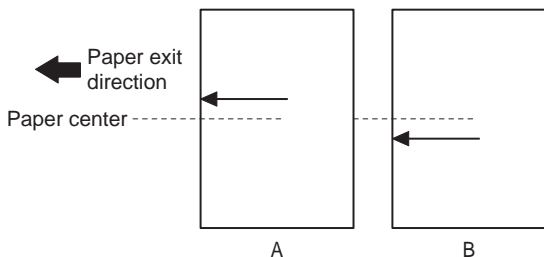

In the case of A decrease the set value.
 In the case of B increase the set value.
 Adjustment specification: Within ± 1.7mm
 (One point of the set value corresponds to the change of about 0.1mm.)

[In the case of the AR-280]

- 4) Make a copy of A4 (8 1/2 × 11) original with the SPF, and measure the off-center.
- 5) Change value C so that the off-center is within the specified range.

[In the case of the AR-285/335]

- 4) Make a copy of A4 (8 1/2 × 11) original with the RADF, and measure the off-center.
- 5) Change value B so that the off-center is within the specified range.
- 6) Press the CA key to cancel the simulation.

D. Image density adjustment

The image density adjustment is required for the following copy quality mode by using the simulation.

There are two methods; the collective adjustment and the individual adjustment of the copy quality mode.

Copy mode (AR-280/285/335)

Copy quality mode		Collective adjustment	Individual adjustment
Binary value mode	Auto mode	SIM46-2	
	Character mode		SIM46-9
	Character/Photo mode		SIM46-10
	Photo mode		SIM46-11
Multi value (Hifi) mode	Auto mode	SIM46-3	
	Character mode		SIM46-5
	Character/Photo mode		SIM46-6
	Photo mode		SIM46-7

Copy mode (AR-250/281/286/336/405)

Copy quality mode		Collective adjustment	Individual adjustment
Binary value mode	Auto mode	SIM46-2	
	Character mode		SIM46-9
	Character/Photo mode		SIM46-10
	Photo (error diffusion) mode		SIM46-11
Multi value (Hifi) mode	Photo (Dither pattern) mode (Japan only)	SIM46-2	SIM46-7

Copy mode (AR-501/505)

Copy quality mode		Collective adjustment	Individual adjustment
Binary value mode	Auto mode	SIM46-2	
	Character mode		SIM46-9
	Character/Photo mode		SIM46-10
	Photo (error diffusion) mode		SIM46-11

(1) Test chart setting

- 1) Place a test chart (UKOG-0162FCZZ) on the original table.
- 2) Place several sheets of A3 (11 × 17) white paper (Sharp's specified paper) on the test chart at the center reference.

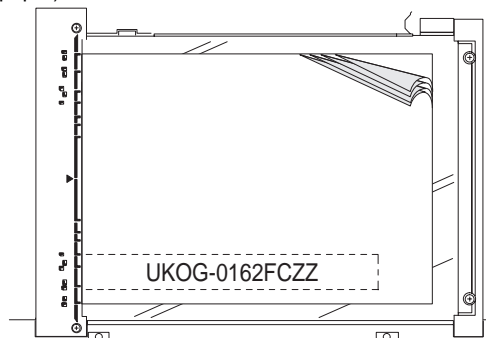

illust: AR-280

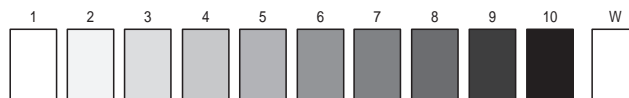

Test chart comparison

UKOG-0162FCZZ DENSITY No.	1	2	3	4	5	6	7	8	9	10	W
UKOG-0089CSZZ DENSITY No.	0.1		0.2		0.3				0.5	1.9	0
KODAK GRAY SCALE		1		2		3		4		19	A
SHARP CORPORATION MADE IN JAPAN											

(2) Density adjustment procedure

a. Collective adjustment of two or more copy quality modes

Normally this adjustment is performed with SIM 46-2 and SIM 46-3. In this method, two or more copy density adjustments in different modes can be adjusted collectively.

- 1) Execute SIM 46-2 and SIM 46-3.

(AR-280/285/335)

(Binary value mode)

Quality mode	Linked simulation data
AE3.0 (AE)	
CH3.0 (Character)	Sim46-9
MIX3.0 (Character/Photo)	Sim46-10
PH3.0 (Photo)	Sim46-11

(AR-250/281/286/336/405)

Quality mode	Linked simulation data
AE3.0 (AE)	
CH3.0 (Character)	Sim46-9
MIX3.0 (Character/Photo)	Sim46-10
PH3.0 (2)	Sim46-11 (Photo error diffusion)
PH3.0 (256)	Sim46-7 (Photo multi value dither) (Japan only)

(AR-501/505)

(Binary value mode)

Quality mode	Linked simulation data
AE3.0 (AE)	
CH3.0 (Character)	Sim46-9
MIX3.0 (Character/Photo)	Sim46-10
PH3.0 (Photo)	Sim46-11

- 2) Press the COPY button to make a copy.

Check that the copy density is as shown in the table below. If not, change the adjustment value.

● Adjustment spec					
Mode	EXP	Chart No.	Adjustment level	Chart No.	Adjustment level
Character	3	3	Copied.	2	Not copied.
Character /Photo	3	3	Copied.	2	Not copied.
Photo	3	3	Copied.	2	Not copied.
Auto		3	Copied.	2	Not copied.

If the copy density is too light, increase the adjustment value.
If the copy density is too dark, decrease the adjustment value.
Adjustment range: 30 - 170

b. Individual adjustment of each copy quality mode

This adjustment is used when a different density level for different copy quality mode is required. SIM 46-5 to -7 and SIM 46-9 to -11 are used.

- 1) Execute the simulation corresponding to the copy quality mode to be adjusted.

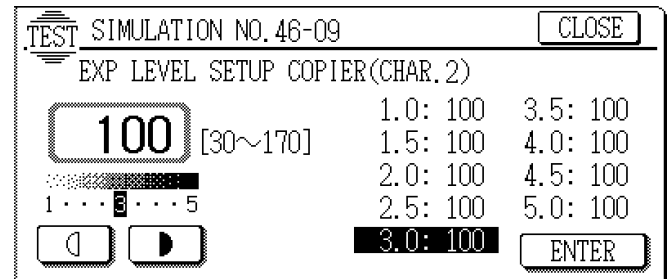

- 2) Press the COPY button to make a copy.

Check that the copy density is as shown in the table below. If not, change the adjustment value.

For the auto mode, there is only one adjustment value. For the other modes, the adjustment value for each density level must be adjusted.

E. Paper feed

(1) Manual paper feed size detection level adjustment

1) Execute SIM 40-2.

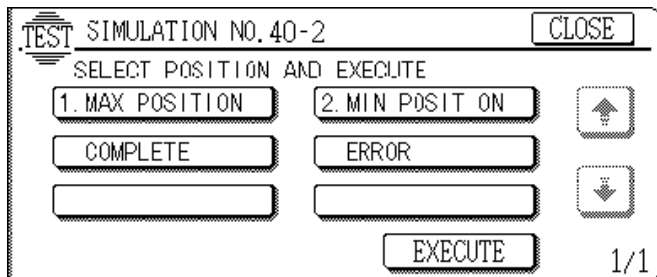

- 2) Extend the manual paper feed guide fully.
- 3) Press [MAX POSITION] on the LCD of the operation panel to highlight it.
- 4) Press [EXECUTE] on the LCD of the operation panel to highlight it.
If normal, the highlight is shifted from [MAX POSITION] to [MIN POSITION].
- 5) Narrow the manual paper feed tray guide fully.
- 6) Press [EXECUTE] on the LCD of the operation panel to highlight it.
Check that [COMPLETE] is highlighted.
- 7) Press the CA key to cancel the simulation.

(2) Paper feed off-center adjustment

When the center of No. 1 and No. 2 paper feed trays is shifted with the reference of manual paper feed and the self print, adjust as follows.

- 1) Loosen the fixing screws a and b of the front cabinet of the paper feed tray.

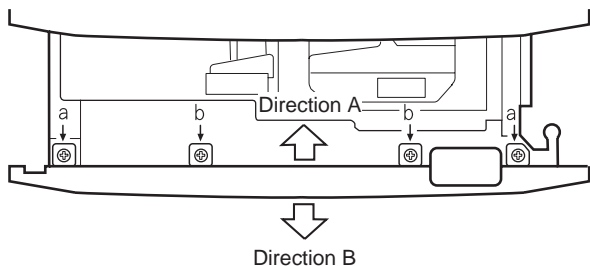

* When fixing the front cabinet, the clearance between fixing screw a and the cabinet and the clearance between fixing screw b and the cabinet are symmetric.

[Reference view]

(Reference view)

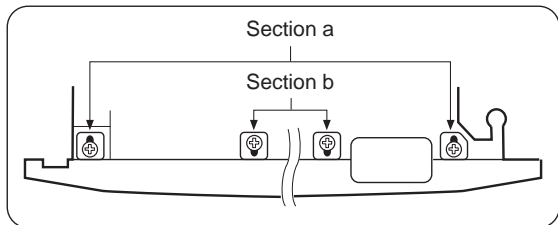

- 2) Shift the front cabinet and adjust.

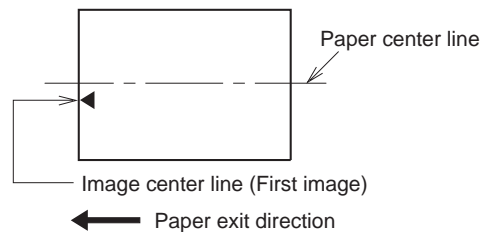

Move the front cabinet in the direction of A.

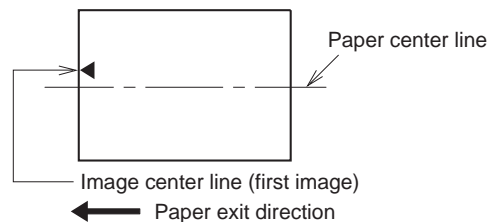

Move the front cabinet in the direction of B.

F. Paper transport

(1) Separation pawl operation timing adjustment

This adjustment is to adjust the time from when the resist roller is turned on to when the drum separation pawl is turned on.

- 1) Execute SIM 51-1.

(AR-250/280/281/285/286/335/336/405)

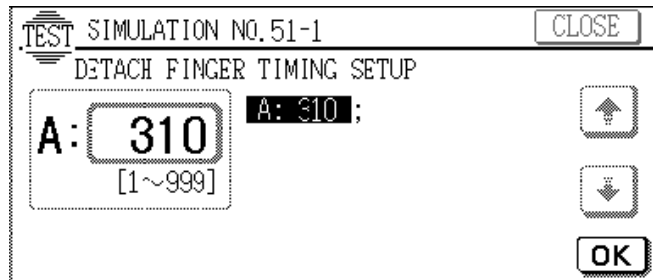

(AR-501/505)

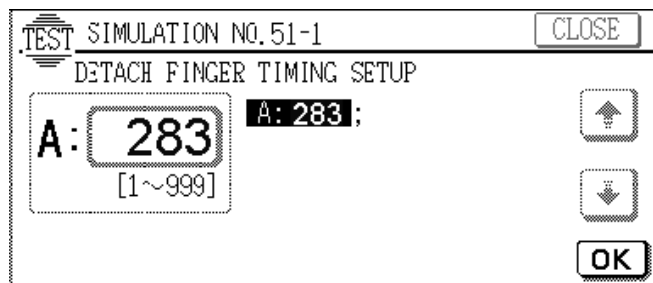

- 2) Change value A and adjust the separation pawl operating timing.

Initial value:	310 ms (283 ms for AR-501/505)
1 step:	1ms
Adjustment range:	1 ~ 999ms
If the adjustment value is improper, a paper jam may resulted.	

(2) Resist amount adjustment

This adjustment is to adjust the timing (paper contact pressure) for the resist roller in each paper feed mode.

By changing the time difference (timing) between the transport roller ON and the resist roller ON, the paper contact pressure on the resist roller is changed.

The adjustment value must be changed according to the copy paper quality.

- 1) Execute SIM 51-2.

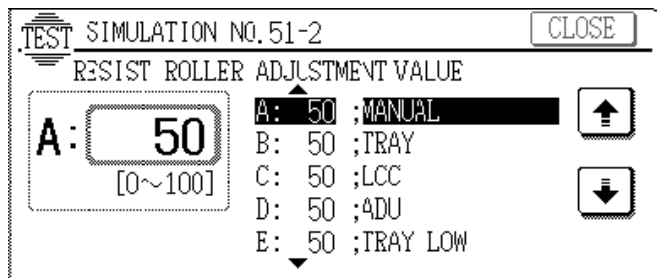

- 2) Change the adjustment value in each mode.

Mode		Initial value (ms)			Set value (ms)
		AR-2XX AR-3XX	AR-4XX	AR-5XX	
A: MANUAL	Manual paper feed	31	55	54	0 ~ 100
B: TRAY	Tray paper feed	55	45	25	0 ~ 100
C: LCC	LCC paper feed	45	45	25	0 ~ 100
D: ADU	ADU paper feed	60	50	25	0 ~ 100
E: TRAY	Tray paper feed (Low)	45	60	—	0 ~ 100
F: LCC	LCC paper feed (Low)	45	—	—	0 ~ 100
G: SPF	SPF paper feed	—	—	—	0 ~ 100
H: DESK	RSPF paper feed	—	—	25	0 ~ 100

1 step: 1ms

* When the set value is too small, the copy image position for the paper may vary.

* When the set value is too great, a paper jam may occur.

G. Others

(1) Original size sensor detection level adjustment

- 1) Execute SIM 41-2.

(Fig. 1)

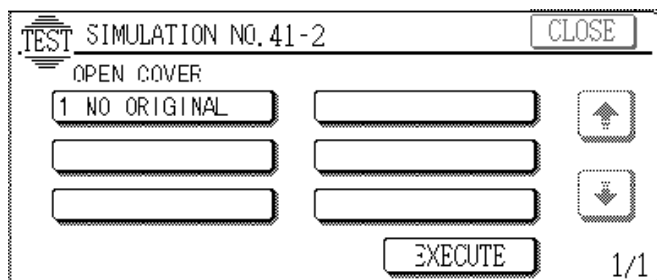

- 2) Execute the sensor adjustment without original.

With the original cover open, without original on the table glass, press the [EXECUTE] key to perform the sensor adjustment without original. After adjustment, NORMAL or ABNORMAL is displayed.

(Fig. 2)

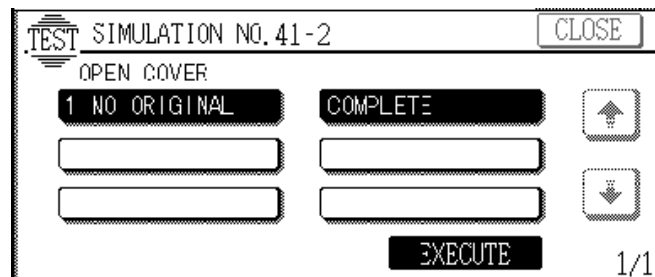

(Fig. 3)

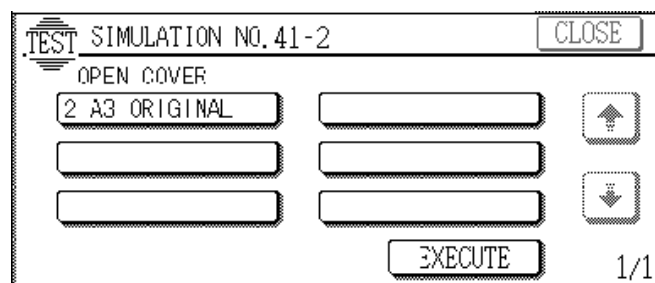

(In the case of NORMAL)

The screen of Fig. 2 is displayed for 1 sec, then the screen of Fig. 3 is displayed, and the sensor adjustment without original is completed.

(Fig. 4)

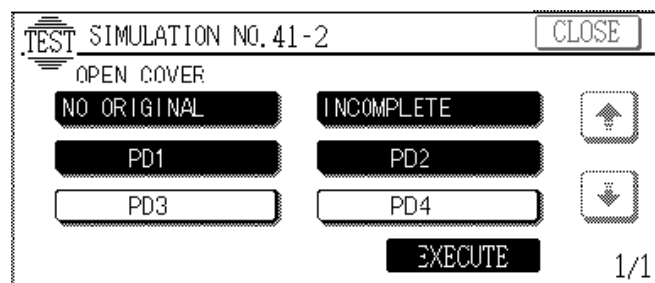

(In the case of ABNORMAL)

The screen of Fig. 4 is displayed, and the sensor of abnormality is highlighted. In this case, confirm the original empty state and press the [EXECUTE] key to perform the sensor adjustment again. 3) Perform the sensor adjustment without original.

- 3) Execute the sensor adjustment with original.

With the original cover open, place five sheets of A3 originals on the glass by fitting them to the original guide, press the [EXECUTE] key to perform the sensor adjustment with originals. After adjustment, NORMAL or ABNORMAL is displayed.

(In the case of NORMAL)

The screen of Fig. 2 is displayed for 1 sec, then the screen of Fig. 3 is displayed to terminate the adjustment of the original sensor.

* In this case, the display item of "2. A3 ORIGINAL" is shown instead of "1. NO ORIGINAL" at the left top.

(In the case of ABNORMAL)

The screen of Fig. 4 is displayed for 1 sec, and the sensor of abnormality is highlighted. In this case, check that there is no A3 original on the original glass, and press the [EXECUTE] key to perform the sensor adjustment operation again.

* In this case, the display item of "2. A3 ORIGINAL" is shown instead of "1. NO ORIGINAL" at the left top.

(2) Original size sensor position adjustment

1) Execute SIM 41-1.

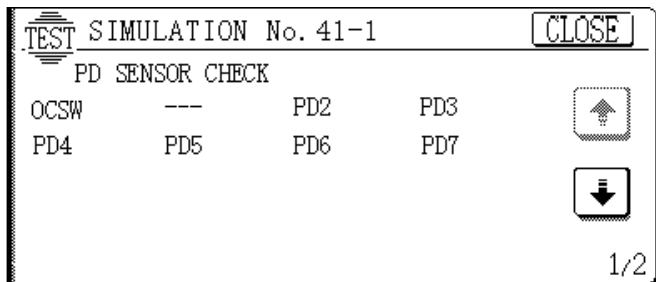

- Slowly tilt the original detecting arm unit, and loosen the original cover switch actuator adjustment screw, and slide and adjust the actuator so that the highlighted display of OCSW is changed to the normal display when the height of the arm unit top from the table glass is 32 ± 0.5 mm. (When the original cover switch ON timing is shifted, the original detection function may not work properly.)

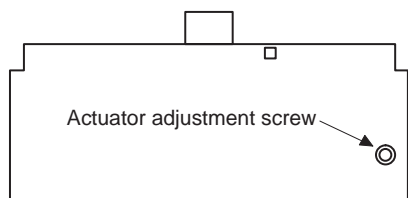
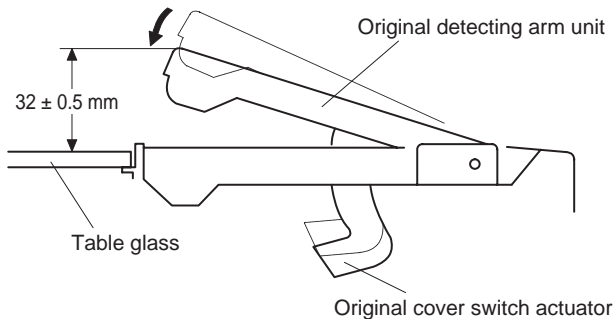

(3) Waste toner full detection level adjustment

1) Fill water to the empty waste toner bottles to make dummy bottle A and B.

Dummy bottle A: 480g (including the bottle weight)

Dummy bottle B: 560g (including the bottle weight)

2) Turn on the power switch of the copier.

3) Install dummy bottle A (480g) to the waste toner bottle detecting unit and check that the weight detection is OFF.

4) Install dummy bottle B (500g) instead and check that the weight detection is ON.

"Weight detection ON" means that the display of "REPLACE TONER BOTTLE" on the panel display is ON. "Weight detection OFF" means that it is OFF.

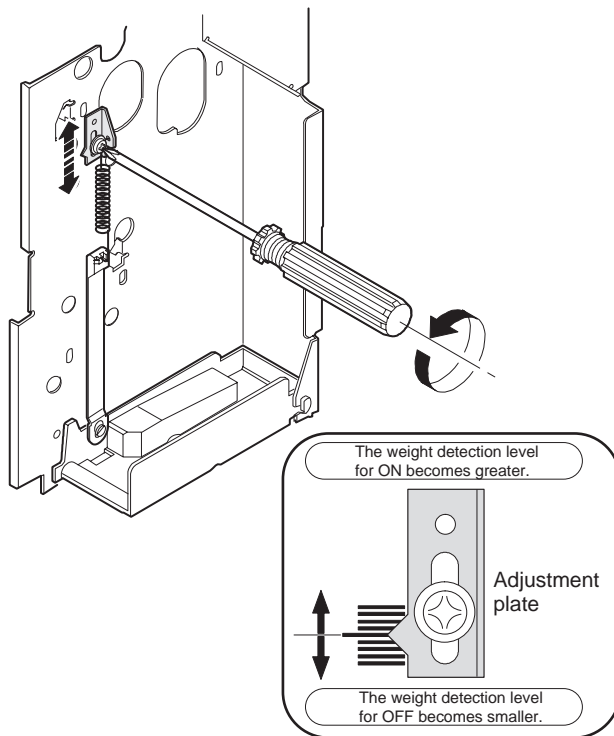

Initial value: 2 scales down from the center

[When ON/OFF display is improper]

Loosen the fixing screw of the positioning plate. Move the positioning plate up and down to adjust so that the weight detection is made as specified.

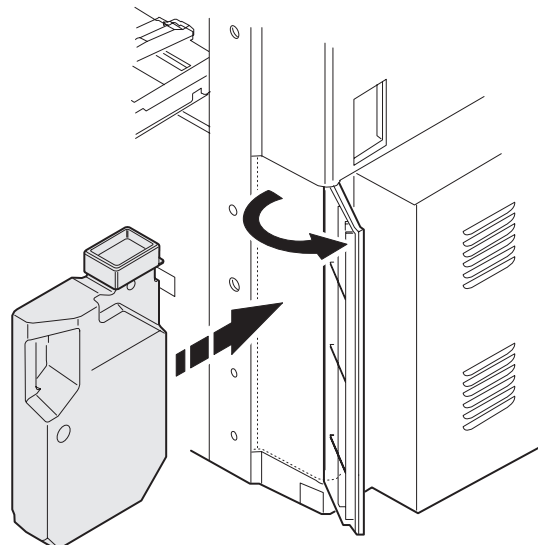

(4) Touch panel adjustment

- 1) Execute SIM 65-1.

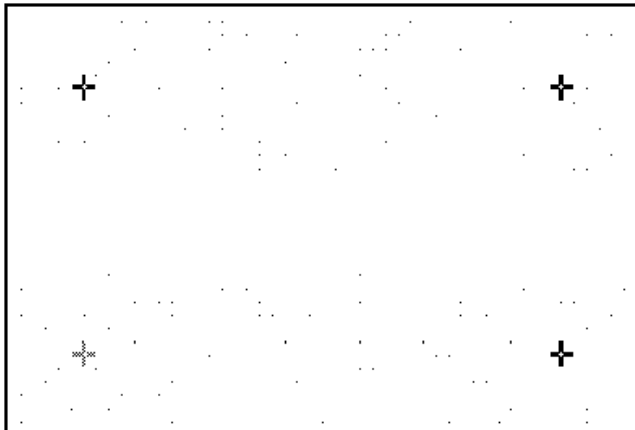

- 2) When the "+" section is pressed, it turns to gray. When all the four points are pressed, the touch panel adjustment is completed and the machine goes into the simulation sub number entry state.

In case of abnormality, the mode returns to the input mode.

* Do not use a sharp pin or needle to press the "+" points.

(5) Key touch sound volume adjustment

This adjustment must be performed in the following cases:

- When the key touch sound volume is too small.
- When the key touch sound volume is too great.
- When the operation control PWB is replaced.

- 1) Remove the operation control PWB.
- 2) Turn the VR1 slider counterclockwise to set at about 135 degrees.

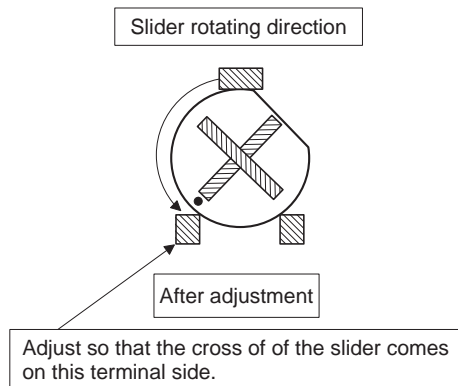

- 3) Use an actual machine and check the key input operations.

After this adjustment:

When the key touch sound volume is too small, turn VR1 clockwise.

When the key touch sound volume is too great, turn VR1 counterclockwise.

H. SPF

(1) Hinge height check and adjustment (Image distortion adjustment)

(Adjustment 1)

Hinge ass'y R hinge space dimension adjustment

- (1) Loosen the two fixing screws of SPF.
- (2) Loosen the nuts, turn the distortion adjustment screw and adjust dimension T to 3.0 mm.
- (3) Tighten two fixing screws of SPF and fix the hinge base.
- (4) Fix the distortion adjustment screw with the nut.

When the distortion adjustment screw is turned in the direction of X (clockwise), the dimension T is increased.

(Turn the distortion adjustment screw in the direction of X (clockwise), and shift the SPF in the direction of arrow as shown above to adjust the dimension T.)

When the distortion adjustment screw is turned in the direction Y (counterclockwise), the dimension T is decreased.

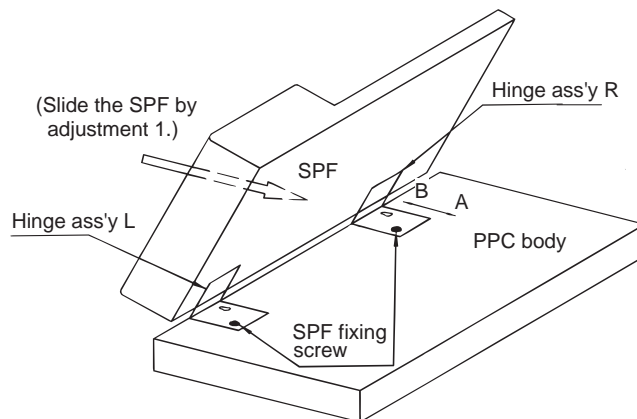
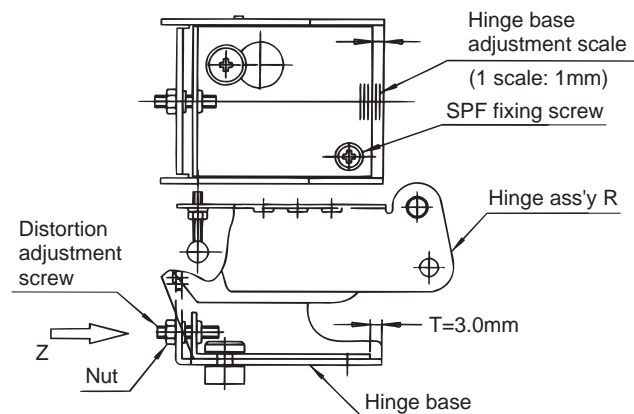

(SPF adjustment direction by turning the distortion adjustment screw)

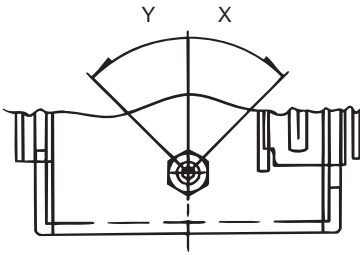

(Adjustment 2)

Hinge ass'y L SPF height a adjustment

- (1) Loosen the nut and turn the height adjustment screw to adjust dimension a to $10 \pm 0.5\text{mm}$.
- (2) After adjusting the height, fix the height adjustment screw with the nut.

Turn the distortion adjustment screw in the direction of C (clockwise) to increase dimension a.

Turn the distortion adjustment screw in the direction of D (counterclockwise) to decrease the dimension a.

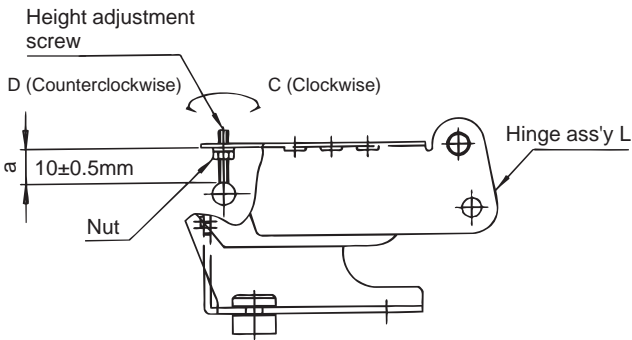

Hinge ass'y R SPF height b adjustment

- (1) Loosen the nut and turn the height adjustment screw to set dimension b to $10 \pm 0.5\text{mm}$.
- (2) After adjusting the height, fix the height adjustment screw and loosen the nut.

When the height adjustment screw is turned in the direction of C (clockwise), the dimension b is increased.

When the height adjustment screw is turned in the direction of D (counterclockwise), the dimension b is decreased.

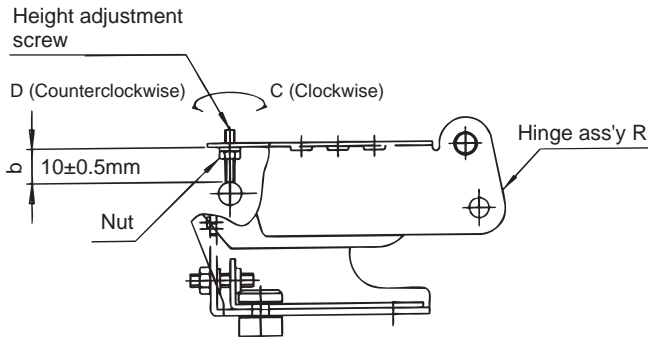

(Image distortion specification)

The right angle distortion of the short side for the long side must be adjusted to less than 1.0 mm.

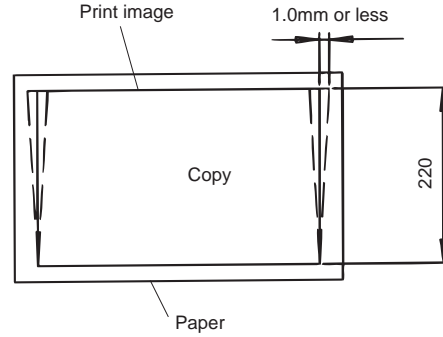

(Distortion pattern and adjustment)

- 1) Check which one of the copy image patterns 1 ~ 8 shown below is like the copy image distortion.
- 2) Follow the adjustment procedure according to the copy image pattern.

(Refer to adjustment 1, 2.)

Note

- 1) When the hinge ass'y R height adjustment is performed, be sure to perform adjustment (2) (Open/close sensor adjustment) again.

Distortion adjustment procedure

(Copy image pattern 1)

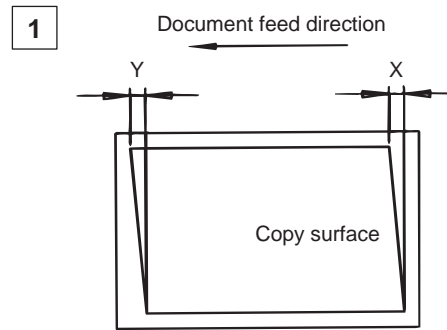

(Adjustment procedure)

- 1) Perform adjustment 1 and adjust the distortion in the X section.

Adjustment reference

When the hinge space T dimension is changed by 1mm, the X dimension is changed by 0.5 ~ 0.7mm,

- 2) If the distortion in the Y section cannot be adjusted with adjustment 1, perform adjustment 2.

Adjustment reference

When the hinge a section dimension is changed by 1mm, the Y dimension is changed by 0.2 ~ 0.4mm,

(Copy image pattern 2)

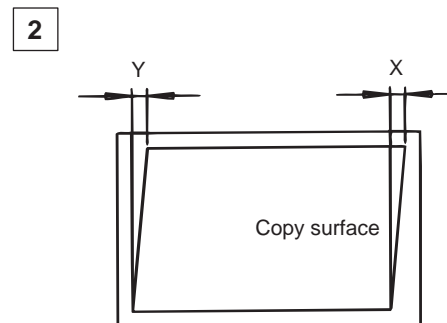

(Adjustment procedure)

- 1) Perform adjustment 1 to adjust the distortion in the X section.

Adjustment reference

When the hinge base T section dimension is changed by 1mm, the X dimension is changed by 0.5 ~ 0.7mm.

- 2) If the distortion in the Y section cannot be adjusted with adjustment 1, perform adjustment 2.

Adjustment reference

When the hinge a section dimension is changed by 1mm, the Y dimension is changed by 0.2 ~ 0.4mm.

(Copy image pattern 3)

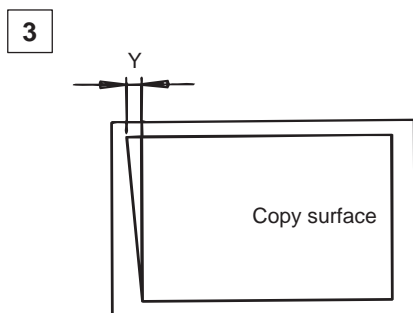

(Adjustment procedure)

- 1) Perform adjustment 2 to adjust the distortion in the Y section.

Adjustment reference

When the hinge section a dimension is changed by 1mm, the Y dimension is changed by 0.2 ~ 0.4mm.

(Copy image pattern 4)

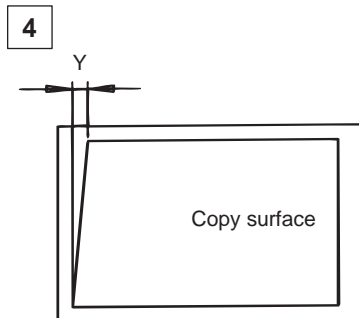

(Adjustment procedure)

- 1) Perform adjustment 2 to adjust the distortion in the Y section.

Adjustment reference

When the hinge section a dimension is changed by 1mm, the Y dimension is changed by 0.2 ~ 0.4mm.

(Copy image pattern 5)

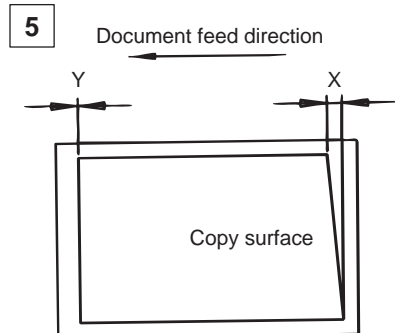

(Adjustment procedure)

- 1) Perform adjustment 1 to adjust the distortion in the X section.

Adjustment reference

When the hinge base T section dimension is changed by 1mm, the X dimension is changed by 0.5 ~ 0.7mm.

- 2) If the distortion in the Y section cannot be adjusted with adjustment 1, perform adjustment 2.

Adjustment reference

When the hinge section a dimension is changed by 1mm, the Y dimension is changed by 0.2 ~ 0.4mm.

(Copy image pattern 6)

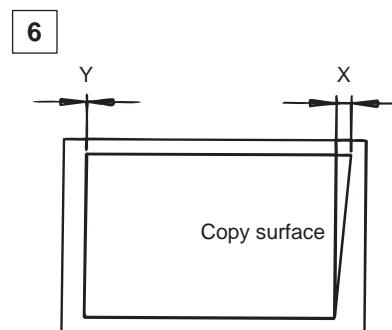

(Adjustment procedure)

- 1) Perform adjustment 1 to adjust the distortion in the X section.

Adjustment reference

When the hinge base T section dimension is changed by 1mm, the X dimension is changed by 0.5 ~ 0.7mm.

- 2) If the distortion in the Y section cannot be adjusted with adjustment 1, perform adjustment 2.

Adjustment reference

When the hinge section a dimension is changed by 1mm, the Y dimension is changed by 0.2 ~ 0.4mm.

(Copy image pattern 7)

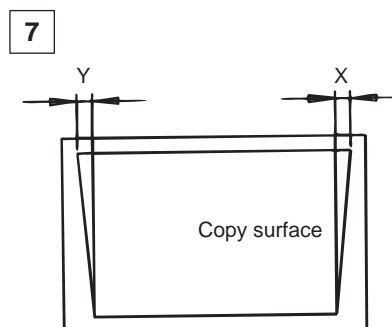

(Adjustment procedure)

- 1) Perform adjustment 1 to adjust the distortion in the X section.

Adjustment reference

When the hinge base T section dimension is changed by 1mm, the X dimension is changed by 0.5 ~ 0.7mm.

- 2) If the distortion in the Y section cannot be adjusted with adjustment 1, perform adjustment 2.

Adjustment reference

When the hinge base T dimension is changed by 1mm, the Y dimension is changed by 0.2 ~ 0.4mm.

(Copy image pattern 8)

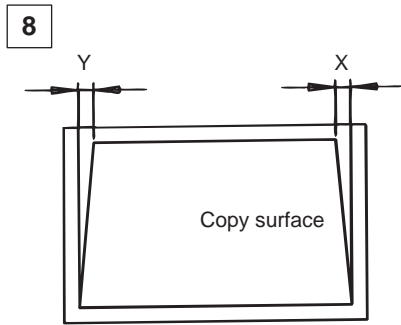

(Adjustment procedure)

- 1) Perform adjustment 1 to adjust the distortion in the X section.

Adjustment reference

When the hinge base T section dimension is changed by 1mm, the X dimension is changed by 0.5 ~ 0.7mm.

- 2) If the distortion in the Y section cannot be adjusted with adjustment 1, perform adjustment 2.

Adjustment reference

When the hinge section a dimension is changed by 1mm, the Y dimension is changed by 0.2 ~ 0.4mm,

(2) Open/close sensor adjustment

- 1) Execute SIM 2-2 by the key operation of the copier.
With the above operation, "AUOD" (automatic document feeder open/close sensor) is displayed on the message screen.
- 2) Check that the open/close sensor (AUOD) is ON when the distance between the base height reference projection (1) inside the automatic document feeder and the table glass (2) is 20 ~ 50mm.

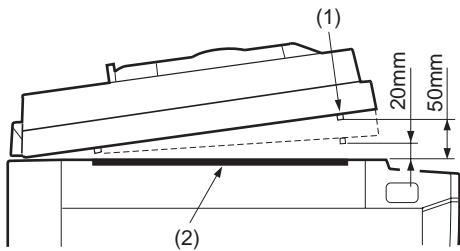

If the distance is shifted, adjust as follows.

- 3) Loosen the fixing screw (2) of the open plate (1) at the rear of the hinge on the right side of the automatic document feeder, and move the open plate up and down to adjust.

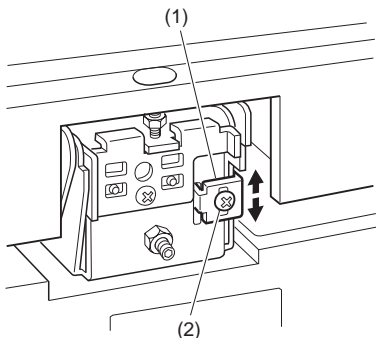

After completion of the adjustment, press the [CA] key to cancel the mode.

I. RADF

(1) Document lead edge stop position adjustment

- The ADF document lead edge stop position is adjusted by using SIM 53.
- When shipping, the lead edge is set to (8). An adjustment may be required depending on documents.
The adjustment range is 8mm (8 steps) in the stopper side and 7mm (7 steps) in the glass side. (1mm: 1 step) For each mode of single, and duplex, the adjustment value can be set independently.

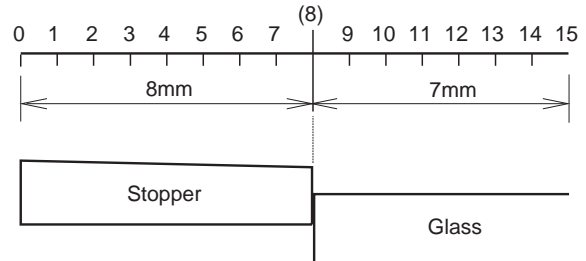

Viewed from the operator

- 1) Execute SIM 53-1 on the copier.

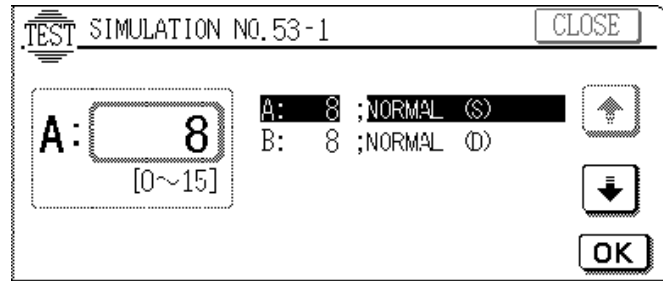

- 2) Enter the stop position adjustment value in each mode.

[Explanation of abbreviation]

NORMAL (S):

Single, normal paper stop position adjustment

NORMAL (D):

Duplex, normal paper stop position adjustment

08: ±0.0000mm (Initial value)	00: -8.000mm	09: +1.000mm
	01: -7.000mm	10: +2.000mm
	02: -6.000mm	11: +3.000mm
	03: -5.000mm	12: +4.000mm
	04: -8.000mm	13: +5.000mm
	05: -8.000mm	14: +6.000mm
	06: -8.000mm	15: +7.000mm
	07: -8.000mm	

(2) Resist/timing/paper exit sensor adjustment

- 1) Execute SIM 53-2 on the copier

(AR-501/505)

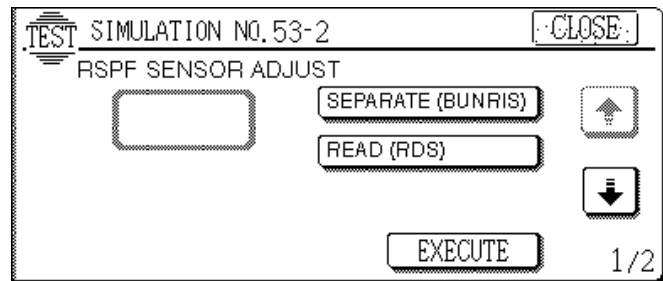

(Other models)

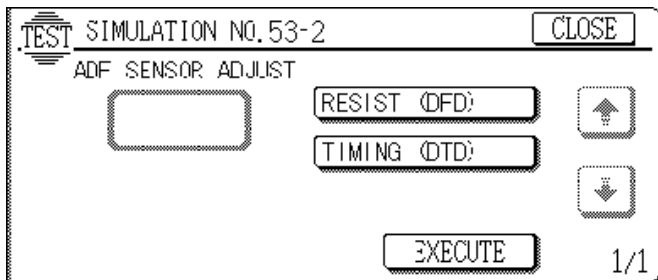

2) Select each sensor and press the EXECUTE key, and the adjustment will be performed automatically.

- RESIST (DFD): Resist sensor
 - TIMING (DTD): Timing sensor
 - REVERSE (RDD): Reverse sensor * 1
- *1: Only when the AR-RF1 is installed.

(3) Test mode with DIP switch

The RADF (ADF) single unit operation can be checked with the DIP switch on the control PWB shown below.

(Control PWB view)

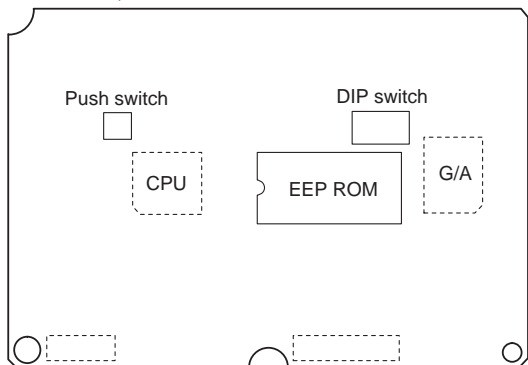

(DIP switch view)

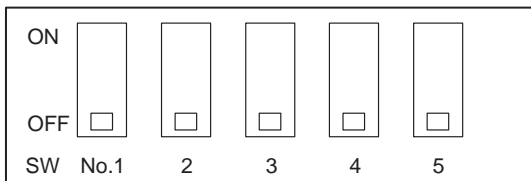

(Operating procedure)

- 1) Remove the control PWB cover.
- 2) Disconnect the connector from the CN9 on the control PWB, and connect the short connector (OCW4074K526//) instead.

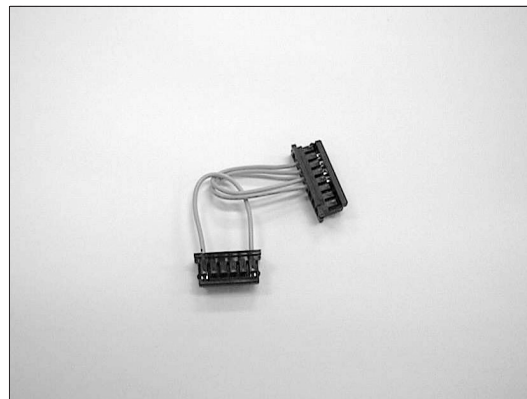
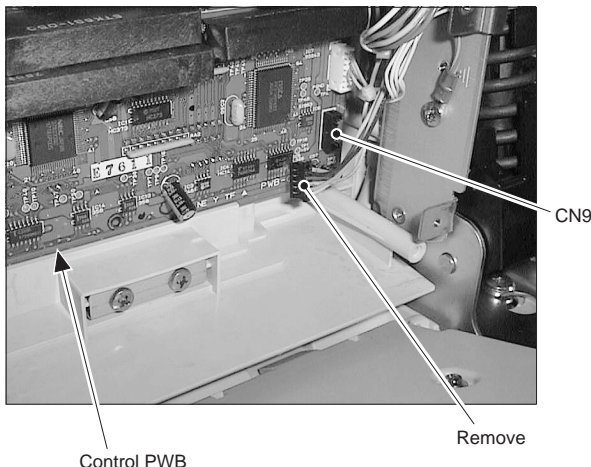

Short connector (OCW4074K526//)

- 3) Remove the ADF/RADF top cover, and set the DIP switch on the control PWB to the desired test mode. While pressing the push switch ON, turn on the power of the machine.

(With the above operation, the machine enters the test mode.)

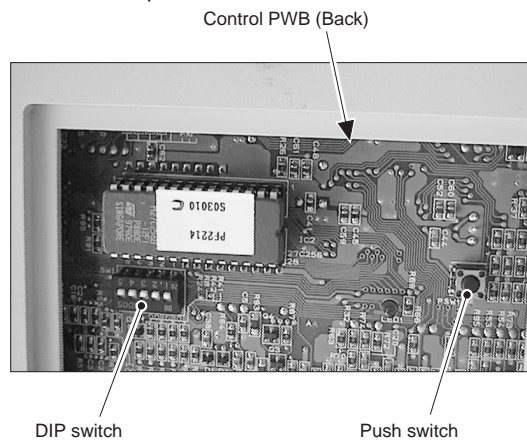

- 4) Turn on the push switch on the control PWB.

(Test operation is started.)

(To switch to another test mode, set the DIP switch on the control PWB to the desired test mode, and open/close the ADF/RADF paper feed section cover (microswitch FGOS it turned OFF and ON).

- DIP switch 3 meaning

	ON	OFF
DIP switch 3	For AB series	For inch series

- Kinds of test modes and setting of DIP switch

No.	Test mode name	DIP switch
a	Single paper pass mode	All OFF
b	Duplex paper pass mode (AR-RF1 only)	1 ON, the others OFF
c	Single aging mode	1, 3 ON, 2, 4, 5 OFF
d	Duplex aging mode (AR-RF1 only)	4 ON, the others OFF
e	Load check mode	1, 5 ON, 2, 3, 4, OFF
f	EEPROM initializing mode + all sensors adjustment mode	3, 5 ON, 1, 2, 4, OFF
g	Resist sensor adjustment mode	4, 5 ON, 1, 2, 3, OFF
h	Timing sensor adjustment mode	1, 4, 5, ON, 2, 3, OFF
i	Paper exit sensor adjustment mode (AR-RF1 only)	3, 4, 5, ON, 1, 2, OFF

a. Single paper pass mode (with paper)

When documents are set on the paper feed tray, the document feed LED lights up. When the push switch is pressed, all documents on the paper feed tray are fed.

b. Duplex paper pass mode (with paper) ... AR-RF1 only

When documents are set on the paper feed tray, the document feed LED lights up. When the push switch is pressed, all documents on the paper feed tray are fed.

c. Single aging mode (without paper)

When the push switch is pressed, aging is started. The operation timing is made by detection of each document size on the tray.

d. Duplex aging mode (without paper) ... AR-RF1 only

When the push switch is pressed, aging is started. The operation timing is made by detection of each document size on the tray.

e. Load check mode

<AR-RF1>

Every time when the push switch is pressed, the operation is performed in the sequence of 1) ~ 21)

- 1) Ready LED OFF/Document remain LED OFF
- 2) Flapper solenoid ON, wait shutter solenoid OFF
- 3) Flapper solenoid OFF
- 4) Ready LED ON/Document remain LED OFF
- 5) Ready LED ON/Document remain LED ON, wait shutter solenoid ON + Paper feed motor normal rotation 250mm/s (preliminary paper feed operation)
- 6) Ready LED OFF/Document remain OFF, paper feed motor OFF
- 7) Ready LED ON/Document LED ON, paper feed motor reverse drive 250mm/s (two-step extending operation)
- 8) Ready LED OFF/Document remain LED OFF, paper feed motor OFF
- 9) Ready LED ON/Document LED ON, paper feed motor reverse drive 800mm/s (paper feed operation)
- 10) Ready LED OFF/Document remain LED OFF, paper feed motor OFF
- 11) Ready LED ON/Document LED ON, transport motor normal drive 800mm/s
- 12) Ready LED OFF/Document remain LED OFF, transport motor OFF
- 13) Ready LED ON/Document LED ON, transport motor reverse drive 800mm/s
- 14) Ready LED OFF/Document remain LED OFF, transport motor OFF
- 15) Ready LED ON/Document LED ON, reverse motor normal drive 800mm/s (reverse operation)
- 16) Ready LED OFF/Document remain LED OFF, reverse motor OFF
- 17) Ready LED ON/Document LED ON, reverse motor normal drive 800mm/s (paper exit operation)
- 18) Reverse motor normal rotation speed change 800 → 300mm/s (paper exit speed reduction)
- 19) Ready LED OFF/Document remain LED OFF, reverse motor OFF
- 20) Ready LED ON/Document LED ON, reverse motor normal drive 300mm/s (paper exit speed reduction)
- 21) Ready LED OFF/Document remain LED OFF, reverse motor OFF

Return to 1).

<AR-AF1>

Every time when the push switch is pressed, the operation is performed in the sequence of 1) - 24).

- 1) Ready LED ON/Document LED ON, wait shutter solenoid ON
- 2) Ready LED OFF/Document remain LED OFF, wait shutter solenoid OFF
- 3) Ready LED ON/Document LED ON, wait shutter solenoid ON + paper feed motor normal drive 250mm/s (preliminary paper feed operation)
- 4) Ready LED OFF/Document remain LED OFF, wait shutter solenoid OFF + paper feed motor OFF
- 5) Ready LED ON/Document LED ON, paper feed motor reverse drive 250mm/s
- 6) Ready LED OFF/Document remain LED OFF, paper feed motor OFF
- 7) Ready LED ON/Document LED ON, paper feed motor reverse drive 831mm/s
- 8) Ready LED OFF/Document remain LED OFF, paper feed motor OFF
- 9) Ready LED ON/Document LED ON, paper feed motor reverse drive 831mm/s
- 10) Paper feed motor reverse rotation speed change 831 → 300mm/s
- 11) Ready LED OFF/Document remain LED OFF, paper feed motor OFF
- 12) Ready LED ON/Document LED ON, transport motor normal drive 831mm/s
- 13) Ready LED OFF/Document remain LED OFF, transport motor OFF
- 14) Ready LED ON/Document LED ON, transport motor normal drive 831mm/s
- 15) Transport motor normal rotation speed change 831 → 300mm/s
- 16) Ready LED OFF/Document remain LED OFF, transport motor OFF
- 17) Ready LED ON/Document LED ON, transport motor normal drive 831mm/s
- 18) Transport motor normal rotation speed change 831 → 300mm/s
- 19) Transport motor normal rotation speed change 300 → 831mm/s
- 20) Ready LED OFF/Document remain LED OFF, transport motor OFF
- 21) Ready LED ON/Document LED ON, transport motor reverse drive 208mm/s (switchback operation)
- 22) Ready LED OFF/Document remain LED OFF, transport motor OFF
- 23) Ready LED ON/Document LED ON, paper exit motor normal drive 300mm/s
- 24) Ready LED OFF/Document remain LED OFF, paper exit motor OFF

Return to 1).

f. EEPROM initializing + all sensors adjustment mode

When the push switch is pressed, the EEPROM is initialized. At that time, the LED blinks at the cycle of 100msec.

After completion of EEPROM initializing, the LED turns ON. In case of an error in the EEPROM initializing, the LED blinks at the cycle of 2000msec.

Then all sensors adjustment is started. At that time, the document remain LED blinks at the cycle of 100msec. After completion of all sensors adjustment, the document remain LED turns ON. In case of an. Error in the all sensors adjustment, the document remain LED blinks at the cycle of 2000msec.

* Only when the EEPROM is successfully completed, the all sensors adjustment is performed.

Kinds of JAM, error	LED display
EEPROM initializing error	Ready LED blinks at the cycle of 2000msec.
All sensors adjustment error	Document remain LED blinks at the cycle of 2000msec

g. Resist sensor adjustment mode

Set the DIP switch (4, 5 to ON, 1, 2, 3 to OFF) and press the push switch. Each sensor adjustment is performed. At that time, the LED blinks at the cycle of 100msec.

After completion of the sensor adjustment, the LED turns ON. In case of an error in the sensor adjustment, the LED blinks at the cycle of 100msec.

Kinds of JAM, error	LED display
Sensor adjustment upper limit error	Document remain LED turns OFF. Ready LED blinks at the cycle of 100msec.
Sensor adjustment lower limit error	Document remain LED blinks at the cycle of 100msec. Ready LED turns OFF

* This mode can be adjusted with SIM 53-2.

h. Timing sensor adjustment mode

Set the DIP switch (1, 4, 5 to ON, 2, 3 to OFF) and press the push switch. Each sensor adjustment is performed. At that time, the LED blinks at the cycle of 100msec.

After completion of the sensor adjustment, the LED turns ON. In case of an error in the sensor adjustment, the LED blinks at the cycle of 100msec.

Kinds of JAM, error	LED display
Sensor adjustment upper limit error	Document remain LED turns OFF. Ready LED blinks at the cycle of 100msec.
Sensor adjustment lower limit error	Document remain LED blinks at the cycle of 100msec. Ready LED turns OFF

* This mode can be adjusted with SIM 53-2.

i. Paper exit sensor adjustment mode

Set the DIP switch (3, 4, 5 to ON, 1, 2 to OFF) and press the push switch. Each sensor adjustment is performed. At that time, the LED blinks at the cycle of 100msec.

After completion of the sensor adjustment, the LED turns ON. In case of an error in the sensor adjustment, the LED blinks at the cycle of 100msec.

Kinds of JAM, error	LED display
Sensor adjustment upper limit error	Document remain LED turns OFF. Ready LED blinks at the cycle of 100msec.

Sensor adjustment lower limit error	Document remain LED blinks at the cycle of 100msec. Ready LED turns OFF
-------------------------------------	--

* This mode can be adjusted with SIM 53-2.

(4) Kinds of error (RADF single mode only)

Kinds of JAM, error	LED display
Not-reaching/remaining JAM in the paper feed section	Document remain LED blinks at the cycle of 1000msec.
Not-reaching/remaining JAM in the paper exit section	Ready LED blinks at the cycle of 1000msec.
Paper feed motor lock error	Document remain LED blinks at the cycle of 2000msec.
Resist/timing sensor adjustment error (when power is supplied)	Document remain LED blinks at the cycle of 100msec.
Paper exit sensor adjustment error (when power is supplied)	Ready LED blinks at the cycle of 100msec.

A JAM/motor lock error can be canceled by opening/closing the ADF after jam recovery process or by applying the power again.

J. RADF (AR-RF2)

(1) Document lead edge stop position adjustment

- The ADF document lead edge stop position is adjusted by using SIM 53.
- When shipping, the lead edge is set to (8). An adjustment may be required depending on documents. The adjustment range is 8mm (8 steps) in the stopper side and 7mm (7 steps) in the glass side. (1mm: 1 step) For each mode of single, and duplex, the adjustment value can be set independently.

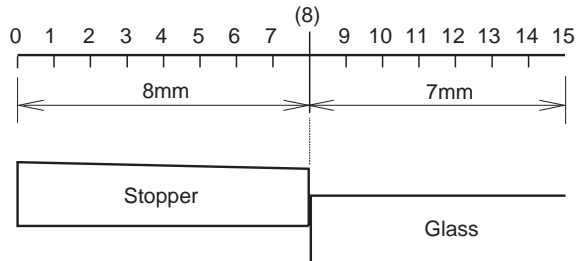

Viewed from the operator

- Execute SIM 53-1 on the copier.

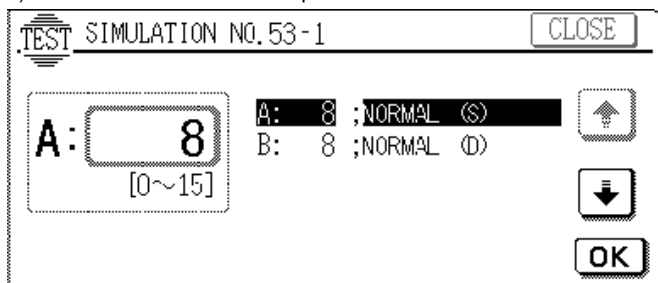

- Enter the stop position adjustment value in each mode.

[Explanation of abbreviation]

NORMAL (S):

Single, normal paper stop position adjustment

NORMAL (D):

Duplex, normal paper stop position adjustment

08: ±0.0000mm	00: -8.000mm	09: +1.000mm
(Initial value)	01: -7.000mm	10: +2.000mm
	02: -6.000mm	11: +3.000mm
	03: -5.000mm	12: +4.000mm
	04: -8.000mm	13: +5.000mm
	05: -8.000mm	14: +6.000mm
	06: -8.000mm	15: +7.000mm
	07: -8.000mm	

(2) Resist/timing/paper exit sensor adjustment

- Execute SIM 53-2 on the copier

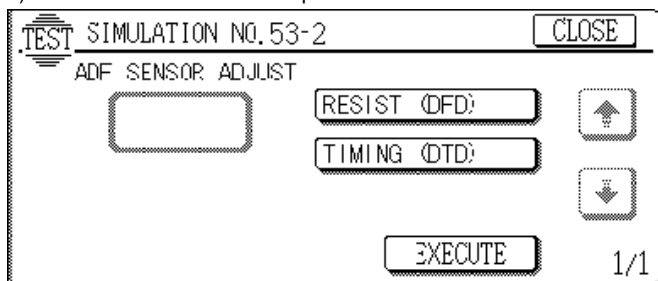

- Select each sensor and press the EXECUTE key, and the adjustment will be performed automatically.

RESIST (DFD):	Resist sensor
TIMING (DTD):	Timing sensor
REVERSE (RDD):	Reverse sensor

(3) Test mode with DIP switch

The RADF (ADF) single unit operation can be checked with the DIP switch on the control PWB shown below.

(Control PWB)

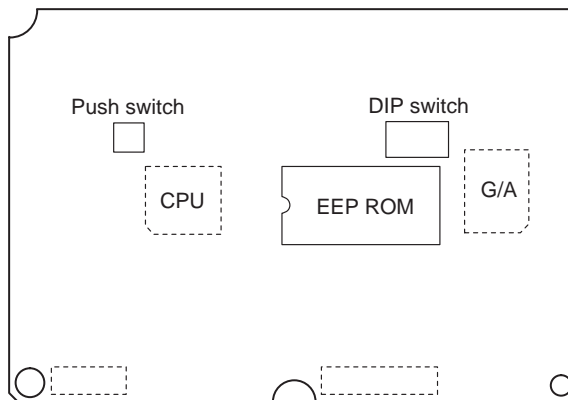

(DIP switch)

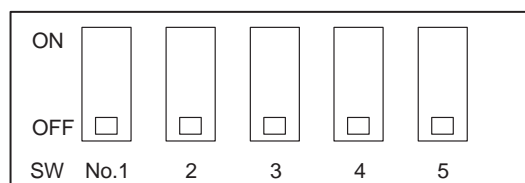

(Operating procedure)

- Remove the control PWB cover.

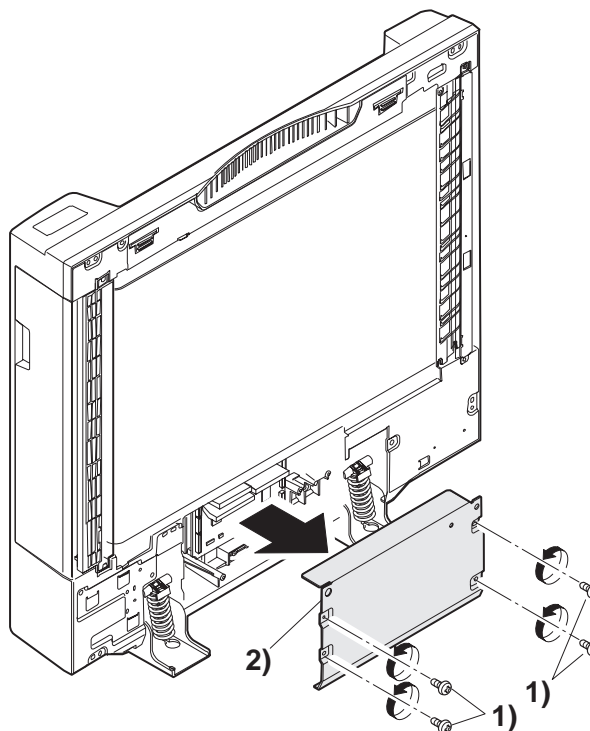

- 2) Disconnect the connector from the CN9 on the control PWB, and connect the short connector (OCW4074K526//) instead.

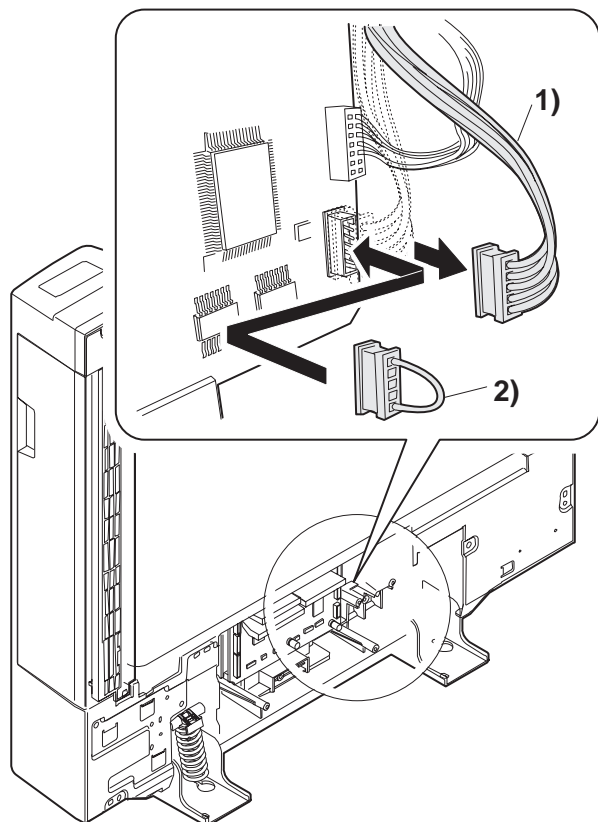

- 3) Remove the ADF/RADF top cover, and set the DIP switch on the control PWB to the desired test mode. While pressing the push switch ON, turn on the power of the machine.

(With the above operation, the machine enters the test mode.)

- 4) Turn on the push switch on the control PWB.

(Test operation is started.)

(To switch to another test mode, set the DIP switch on the control PWB to the desired test mode, and open/close the ADF/RADF paper feed section cover (microswitch FGOD is turned OFF and ON).

- DIP switch 3 meaning

	ON	OFF
DIP switch 3	For AB series	For inch series

- Kinds of test modes and setting of DIP switch

No.	Test mode name	DIP switch
a	Single paper pass mode	All OFF
b	Duplex paper pass mode	1 ON, the others OFF
c	Single aging mode	1, 3 ON, 2, 4, 5 OFF
d	Duplex aging mode	4 ON, the others OFF
e	Load check mode	1, 5 ON, 2, 3, 4, OFF
f	EEPROM initializing mode + all sensors adjustment mode	3, 5 ON, 1, 2, 4, OFF
g	Resist sensor adjustment mode	4, 5 ON, 1, 2, 3, OFF
h	Timing sensor adjustment mode	1, 4, 5, ON, 2, 3, OFF
i	Paper exit sensor adjustment mode (AR-RF1 only)	3, 4, 5, ON, 1, 2, OFF

a. Single paper pass mode (with paper)

When documents are set on the paper feed tray, the document feed LED lights up. When the push switch is pressed, all documents on the paper feed tray are fed.

b. Duplex paper pass mode (with paper)

When documents are set on the paper feed tray, the document feed LED lights up. When the push switch is pressed, all documents on the paper feed tray are fed.

c. Single aging mode (without paper)

When the push switch is pressed, aging is started. The operation timing is made by detection of each document size on the tray.

d. Duplex aging mode (without paper)

When the push switch is pressed, aging is started. The operation timing is made by detection of each document size on the tray.

e. Load check mode

Set the DIP switch on the control PWB as shown below, and open and close the ADF/ RADF paper feed section cover to enter the load check mode.

(DIP switch)

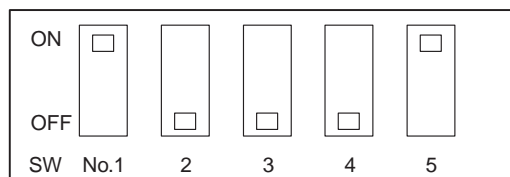

Every time when the push switch is pressed, the operation is performed in the sequence of 1) ~ 21)

- 1) Document feed LED ON, Document remain LED ON, Paper feed solenoid ON
- 2) Reverse solenoid ON, Paper feed solenoid OFF
- 3) Document feed LED OFF, Document remain LED OFF, Reverse solenoid OFF
- 4) Document feed LED ON, Document remain LED OFF, Paper feed solenoid ON, Paper feed motor forward rotation 450mm/s (Preliminary paper feed operation)
- 5) Document feed LED OFF, Document remain LED OFF, Paper feed solenoid OFF, Paper feed motor OFF
- 6) Document feed LED ON, Document remain LED ON, Paper feed motor reverse rotation 450mm/2 (2-step advanced feed)
- 7) Document feed LED OFF, Document remain LED OFF, Paper feed motor OFF
- 8) Document feed LED ON, Document remain LED ON, Paper feed motor reverse rotation 850mm/s (Paper feed operation)
- 9) Document feed LED OFF, Document remain LED OFF, Paper feed motor OFF
- 10) Document feed LED ON, Document remain LED ON, Transport motor forward rotation 867mm/s
- 11) Document feed LED OFF, Document remain LED OFF, Transport motor OFF
- 12) Document feed LED ON, Document remain LED ON, Transport motor reverse rotation 867mm/s
- 13) Document feed LED OFF, Document remain LED OFF, Transport motor OFF
- 14) Document feed LED ON, Document remain LED ON, Reverse motor forward rotation 867mm/s (reverse operation)
- 15) Document feed LED OFF, Document remain LED OFF, Reverse motor OFF
- 16) Document feed LED ON, Document remain LED ON, Reverse motor forward rotation 867mm/s (Pulling/paper exit operation)

- 17) Reverse motor speed reduction 867 → 297mm/s (Paper exit speed reduction)
- 18) Document feed LED OFF, Document remain LED OFF, Reverse motor OFF
- 19) Document feed LED ON, Document remain LED ON, Reverse motor forward rotation 867mm/s (Paper exit operation)
- 20) Reverse motor speed reduction 867 → 297mm/s (Paper exit speed reduction)
- 21) Document feed LED OFF, Document remain LED OFF, Reverse motor OFF

Kinds of JAM, error	LED display
Paper feed motor lock error	REMOVE ORIGINAL LED blinks at the cycle of 2000msec.

Return to 1).

f. EEPROM initializing + all sensors adjustment mode

When the DIP switch is set (3, 5 to ON, 1, 2, 4 to OFF) the push switch is pressed, the EEPROM is initialized. At that time, the LED blinks at the cycle of 100msec.

After completion of EEPROM initializing, the LED turns ON. In case of an error in the EEPROM initializing, the LED blinks at the cycle of 2000msec.

Then all sensors adjustment is started. At that time, the document remain LED blinks at the cycle of 100msec. After completion of all sensors adjustment, the document remain LED turns ON. In case of an. Error in the all sensors adjustment, the document remain LED blinks at the cycle of 2000msec.

* Only when the EEPROM is successfully completed, the all sensors adjustment is performed.

Kinds of JAM, error	LED display
EEPROM initializing error	Ready LED blinks at the cycle of 2000msec.
All sensors adjustment error	Document remain LED blinks at the cycle of 2000msec

g. Resist sensor adjustment mode

Set the DIP switch (4, 5 to ON, 1, 2, 3 to OFF) and press the push switch. Each sensor adjustment is performed. At that time, the LED blinks at the cycle of 100msec.

After completion of the sensor adjustment, the LED turns ON. In case of an error in the sensor adjustment, the LED blinks at the cycle of 100msec.

Kinds of JAM, error	LED display
Sensor adjustment upper limit error	Document remain LED turns OFF. Ready LED blinks at the cycle of 100msec.
Sensor adjustment lower limit error	Document remain LED blinks at the cycle of 100msec. Ready LED turns OFF

* This mode can be adjusted with SIM 53-2.

h. Timing sensor adjustment mode

Set the DIP switch (1, 4, 5 to ON, 2, 3 to OFF) and press the push switch. Each sensor adjustment is performed. At that time, the LED blinks at the cycle of 100msec.

After completion of the sensor adjustment, the LED turns ON. In case of an error in the sensor adjustment, the LED blinks at the cycle of 100msec.

Kinds of JAM, error	LED display
Sensor adjustment upper limit error	Document remain LED turns OFF. Ready LED blinks at the cycle of 100msec.
Sensor adjustment lower limit error	Document remain LED blinks at the cycle of 100msec. Ready LED turns OFF

* This mode can be adjusted with SIM 53-2.

i. Paper exit sensor adjustment mode

Set the DIP switch (3, 4, 5 to ON, 1, 2 to OFF) and press the push switch. Each sensor adjustment is performed. At that time, the LED blinks at the cycle of 100msec.

After completion of the sensor adjustment, the LED turns ON. In case of an error in the sensor adjustment, the LED blinks at the cycle of 100msec.

Kinds of JAM, error	LED display
Sensor adjustment upper limit error	Document remain LED turns OFF. Ready LED blinks at the cycle of 100msec.
Sensor adjustment lower limit error	Document remain LED blinks at the cycle of 100msec. Ready LED turns OFF

* This mode can be adjusted with SIM 53-2.

(4) Kinds of error (RADF single mode only)

Kinds of JAM, error	LED display
Not-reaching/remaining JAM in the paper feed section	Document remain LED blinks at the cycle of 1000msec.
Not-reaching/remaining JAM in the paper exit section	Ready LED blinks at the cycle of 1000msec.
Paper feed motor lock error	Document remain LED blinks at the cycle of 2000msec.
Resist/timing sensor adjustment error (when power is supplied)	Document remain LED blinks at the cycle of 100msec.
Paper exit sensor adjustment error (when power is supplied)	Ready LED blinks at the cycle of 100msec.

A JAM/motor lock error can be canceled by opening/closing the ADF after jam recovery process or by applying the power again.

K. RSPF

There are following items of adjustments by the simulations of the machine.

Name	Adjustment items	Adjustment value (Key operation on the machine)	Note
Lead edge position adjustment	The lead edge and the image lead edge are adjusted in the range of +5mm to +5mm. (Front and back surface of a document)	0 ~ 100	SIM 50-1/2 SIM 50-6/7 Default: 50
Magnification ratio adjustment	The magnification ration is corrected. (-4.9% to +4.9%)(Front and back surface of a document)	1 ~ 99	SIM 48-1 Default: 50
Resist quantity adjustment	No. 1 resist (front surface of document) loop quantity adjustment (0.1mm ~ 9.9mm)	1 ~ 99	SIM 51-2 Default: 50
	No. 2 resist (front surface of document) loop quantity adjustment (0.1mm ~ 6.9mm)	31 ~ 99	SIM 51-2 Default: 50
Image loss adjustment	The output timing of data enable signal (DEN) is adjusted and data write from the image lead edge to the set quantity is cut. (0 ~ 10mm)	0 ~ 100	SIM 50-1/2 SIM 50-6/7 Default: 50
Center shift adjustment			SIM 50-12
Reflection type sensor adjustment	Automatic initialization of the post-separation sensor, the read sensor, and the SB sensor is performed.		SIM 53-2

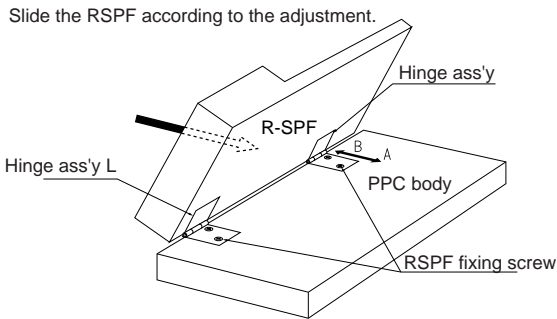
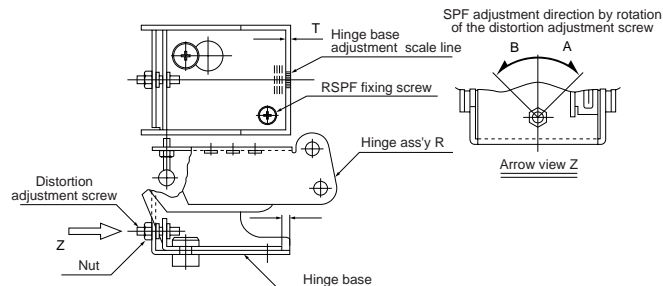

Image distortion adjustment procedure

Adjustment of hinge base dimension T of hinge ass'y R

- (1) Loosen the RSPF fixing screw.
 - (2) Loosen the nut and turn the distortion adjustment screw to adjust dimension T.
 - (3) Tighten two SPF fixing screws to fix the hinge base.
 - (4) Tighten the nut with the distortion adjustment screw fixed.
- (Adjustment 1) Turn the distortion adjustment screw in direction of A.
— Dimension T is increased.
- (Adjustment 2) Turn the distortion adjustment screw in direction of B.
— Dimension T is decreased.



(Adjustment procedure)

- 1) Perform Adjustment 1 to adjust the distortion in X section.

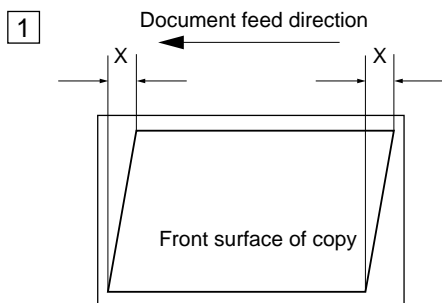

- 1) Perform Adjustment 1 to adjust the distortion in Y section.

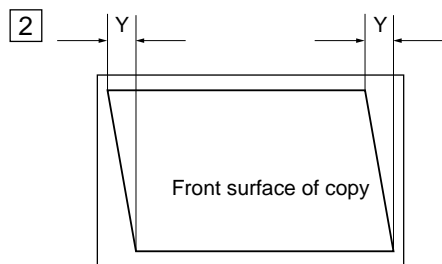

Back surface resist adjustment

Back surface resist adjustment by the SB resist adjustment plate

- (1) Loosen the fixing scrw.
- (2) If the copied image is as shown in 1, shift and adjust the adjustment plate in the direction of A.

If the copied image is as shown in 2, shift and adjust the adjustment plate in the direction of B.

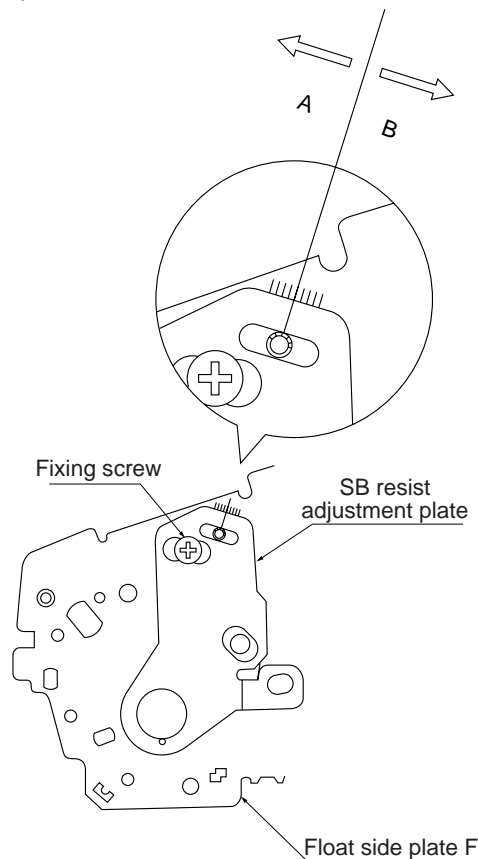

(Set document)

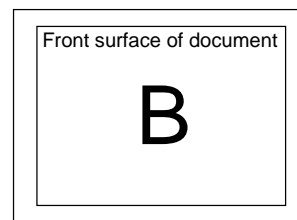

(Copy)
Copy 1

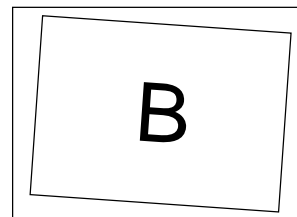

Copy 2

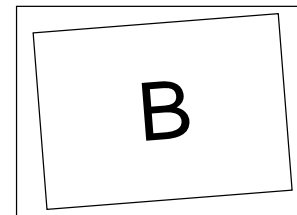

Skew adjustment

Skew adjustment by the upper guide and the lower guide

- (1) Loosen four fixing screws.
- (2) If the copied image is as shown in 1 , shift and adjust the adjustment plate in the direction of A. If the copied image is as shown in 2 , shift and adjust the adjustment plate in the direction of B.

(Set document)

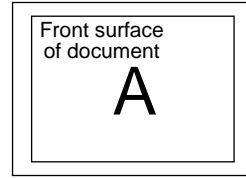

(Copy)

Copy 1

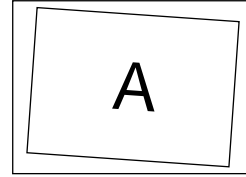

Copy 2

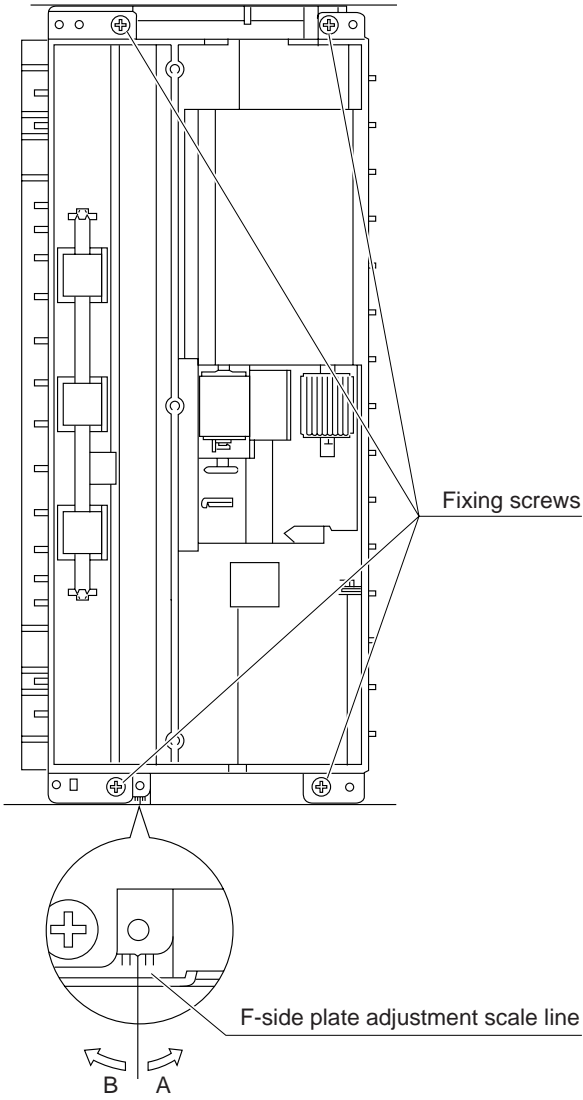
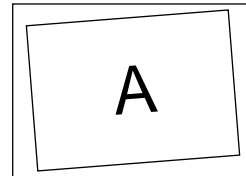

[7] SIMULATION

(Diagnostics, setting, adjustment value input, data display)

1. Outline and purpose

There are following, simulation functions to check the machine operations, troubleshoot, find causes, make various settings, improve adjustment work speeds and serviceability.

- 1) Various adjustments
- 2) Specification and function setting
- 3) Trouble cancel
- 4) Operation check
- 5) Counters check, setting, clear
- 6) Machine operation conditions (operation history) data check, clear
- 7) Transmission of various data (adjustment, setting, operations, counter, etc.)

The operating procedures and displays slightly differ from the form of the machine operation panel.

The typical forms are as follows:

- 1) Code system: Values input and mode selection are made with the 10-key pad and various function keys.
- 2) Switch system: Simulation mode selection is made by combination of switch setting.
- 3) Values and mode selection is made with various function keys. As a special one, a jumper wire is used to connect the check points on the PWB to select the desired mode.

2. Code system simulation

A. Operating procedures and operations

* Entering the simulation mode

- 1) Program (P) key → Interrupt key → Clear key → Interrupt key
(The machine enters the standby mode for the simulation main code.)
- 2) Enter the main code with 10-key pad. → Press START key.
- 3) Enter the sub code of with 10-keypad. → Press START key.
- 4) Select the mode and the item with the 1-key pad and the function key.
- 5) The machine enters the selected mode.

To start the simulation, press the START key or the function key.

To cancel the current simulation mode and to change the main code and the sub code, press the interrupt key.

* The simulation mode is canceled and the machine returns to the normal operation mode.

- 1) Press the all clear key.

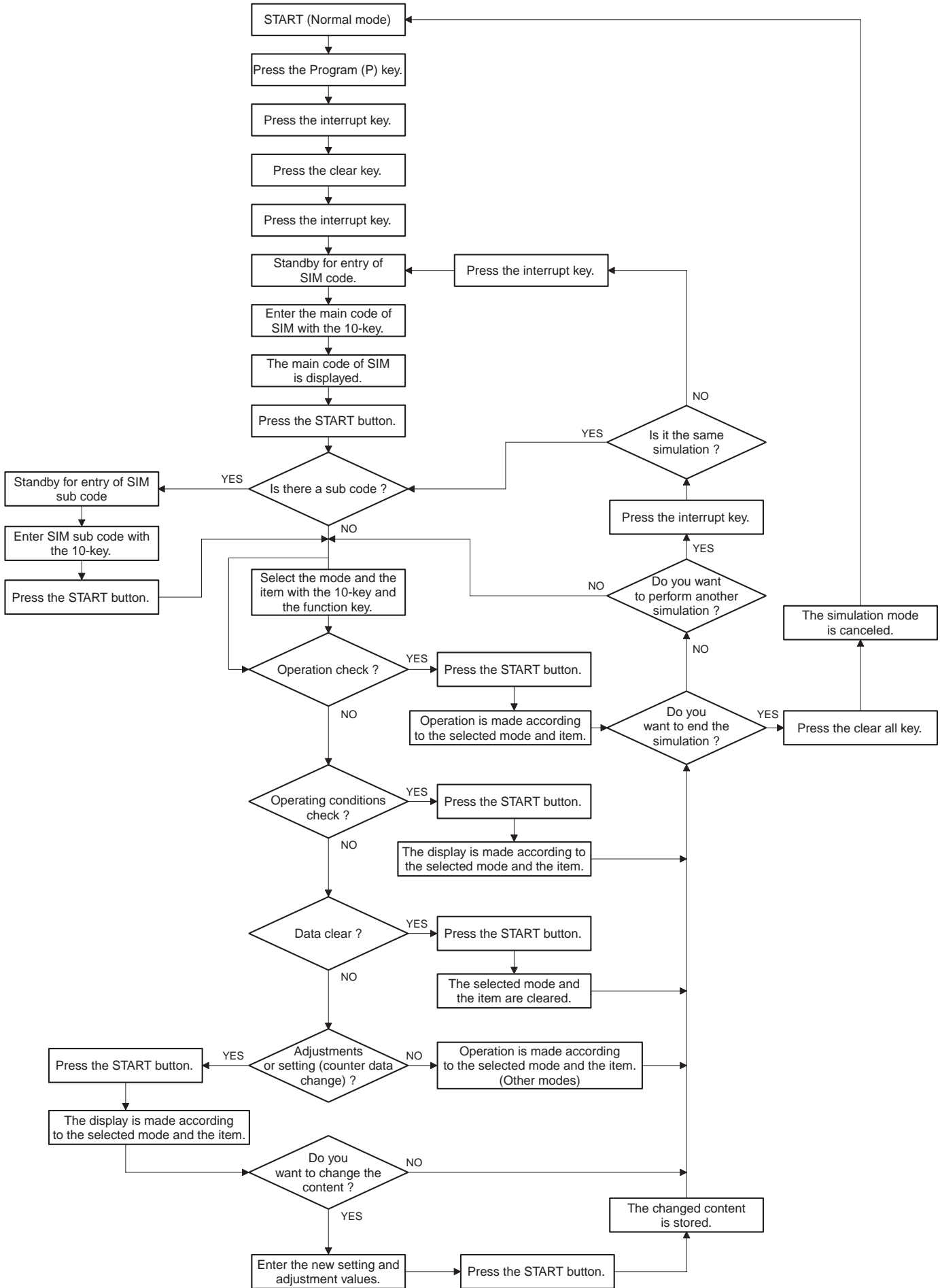

[Descriptive Conventions]

For the sake of keeping the use of information common among several models, this manual uses the following conventions:

- AR-5XX: Refers to model AR-501/505,
 AR-4XX: Refers to model AR-405,
 AR-2X1/3X1/4XX/250/XX6: AR-281/286/405/250/336,
 AR-2XX, 3XX: Refers to model AR-280/285/335 for this issue.
 * The "X" stands for any numeral 0 to 9.

B. List

Code		Function (Purpose)
Main	Sub	
1	1	Used to check the operation of the scanner unit and its control circuit.
	2	Used to check the operation of sensors and detectors in the scanner section and the related circuit.
2	1	Used to check the operation of the SPF/ADF/RSPF/RADF unit and its control circuit.
	2	Used to check the operation of sensors and detectors in the SPF/ADF/RSPF/RADF units and the related circuit.
	3	Used to check the operation of the loads in the SPF/ADF/RSPF/RADF units and the control circuits.
3	2	Used to check the operation of sensors and detectors in the sorter and the related circuit.
	3	Used to check the operation of the loads in the sorter and the control circuit.
	6	Used to adjust the finisher stacking capability. (Used to adjust the stop position of the finisher paper width direction alignment plate (jogger). This adjustment is made by changing the width direction alignment plate home position by the software.)
4	2	Used to check the operation of sensors and detectors in the paper feed section (desk feed, large capacity tray) and the related circuit.
	3	Used to check the operation of the loads in the paper feed section (desk paper feed, large capacity tray) and the control circuits.
5	1	Used to check the operation of the display, LCD in the operation panel, and control circuit.
	2	Used to check the operation of the heater lamp and the control circuit.
	3	Used to check the operation of the copy lamp and the control circuit.
	4	Used to check the operation of the discharge lamp and the control circuit.
	6	Used to check the operation of the separation lamp and its control circuit. (AR-501/505 only)
6	1	Used to check the operation of the loads (clutches and solenoids) in the paper transport system and the control circuit.
	2	Used to check the operation of each fan motor and its control circuit.
7	1	Used to set the aging operation conditions.
	6	Used to set the cycle of intermittent aging.
	8	Used to set YES/NO of display of the warmup time.
8	1	Used to check and adjust the operation of the developing bias voltage in each print mode and the control circuit. (for OPC drum type B)
	2	Used to check and adjust the operation of the main charger grid voltage in each print mode and the control circuit. (for OPC drum type B)
	6	Used to check and adjust the transfer charger current and the control circuit.
	7	Used to check and adjust the operation of the separation charger voltage and its control circuit.
9	1	Used to check the operation of the loads (clutches and solenoids) in the duplex section and the control circuit.
	2	Used to check the operation of sensors and detectors in the duplex section and the control circuit.
	4	Used to check the operation of the duplex unit alignment plate and its control circuit.

Code		Function (Purpose)
Main	Sub	
10	0	Used to check the operation of the toner motor and its control circuit. (Note) Do not execute this simulation with toner in the toner hopper. If executed, excessive toner may enter the developing section, causing an overtoner trouble. Be sure to remove the toner motor from the toner hopper before executing this simulation.
	13	Used to cancel the self diag U1 trouble.
14	0	Used to cancel the self diag U1/LOC/U2/PF troubles.
15	0	Used to cancel the self diag U4 - 09/20/21/22 (large capacity tray) trouble.
16	0	Used to cancel the self diag U2 trouble.
17	0	Used to cancel copy inhibition by the host computer during the self diag PF.
21	1	Used to set the maintenance cycle.
22	1	Used to check the print out count of each section in each operation mode. (Used to check the maintenance timing.)
	2	Used to check the total numbers of misfeed and troubles. (When the number of misfeed is considerably great, it is judged as necessary for repair. The misfeed rate is obtained by dividing this count value with the total counter value.)
	3	Used to check the misfeed positions and the number of misfeed in each position. (If the number of misfeed is considerably great, it can be judged as necessary for repair.) (Sections other than ADF/RADF/SPF sections)
	4	Used to check the total trouble (self diag) history.
	5	Used to check the ROM version of each unit (section).
	6	Used to output the list of the setting and adjustment data (simulations, FAX soft switch, counters).
	7	Used to display the key operator code. (This simulation is used when the customer forgets the key operator code.)
	8	Used to check the number of use of the staple, the ADF, RADF, SPF, and scanning.
	9	Used to check the number of use of each paper feed section. (the number of prints)
	10	Used to check the system configuration (option, internal hardware).
	11	Used to check the use frequency of FAX (send/receive). (FAX model only)
	12	Used to check the misfeed positions and the number of misfeed at each position. (When the number of misfeed is considerably great, it can be judged as necessary for repair.)
24	1	Used to clear the misfeed counter, the misfeed history, the trouble counter, and the trouble history. (The counters are cleared after completion of maintenance.)
	2	Used to clear the number of use (the number of prints) of each paper feed section.
	3	Used to clear the data of the number of use of the staple, the SPF, ADF, RSPF, RADF and scanning.
	4	Used to reset the maintenance counter.
	5	Used to reset the developer quantity counter. (The developer counter of the installed developing unit is reset.)
	6	Used to reset the copy counter.
	7	Used to clear the OPC drum (membrane decrease) correction counter. (This simulation is executed when the OPC drum is replaced.)
	8	Used to clear the Zaurus print counter.

Code		Function (Purpose)
Main	Sub	
24	9	Used to clear the printer print counter. (The counter is cleared after completion of maintenance.)
	11	Used to reset the developer rotation time counter. (The developer counter of the installed developing unit is reset.) (AR-501/505 only)
25	1	Used to check the operation of the main drive (excluding the scanner section) and to check the operation of the toner concentration sensor. (The toner concentration sensor output can be monitored.)
	2	Used to make the initial setting of toner concentration when replacing developer.
	8	Used to set the timing of toner concentration control correction B and the correction quantity. The timing is determined according to the accumulated use time of developer. (AR-501/505 only)
26	1	Used to set options. (This simulation is used to make option setting when an option is installed.)
	2	1) Used to set the paper size of the large quantity paper tray. (When the paper size is changed, the lift paper size must be also changed with this simulation.) 2) Used to detect the paper or document size of 8.5" x 13" (Inch series) and set the display mode. (All paper feed modes)
	3	Used to set the specifications of the auditor. Setting must be made depending on the use condition of the auditor.
	5	Used to set the count mode of the total counter and the maintenance counter.
	6	Used to set the specifications depending on the destination.
	15	Used to set the fusing operation mode (paper curl corresponding mode).
	18	Used to set VALID/INVALID of toner save operation. (This simulation is valid only in the Japan and UK versions. (It depends on SIM 26-6 (Destination setting). For the other destinations, the same setting can be executed with the user program.)
	22	Used to set the specification (language display) for the destination. (Excluding the Japan models.)
	30	Used to set the CE mark conforming operation mode. (For flickers when driving the fusing heater lamp.)
	35	Used to set whether the trouble history display of SIM 22-4 is displayed as one trouble or as the number of continuous troubles when two or more troubles of a same kind occurred.
	36	Used to set the ICU fan operating temperature. (Operation in the pre-heat mode.) (Excluding Japan models.)
	40	Polygon motor stop mode setup (AR-501/505) Used to set the stop time of the polygon motor after leaving in ready state and to set Enable/Disable of the setting. (Other models)
	41	Used to enable/disable the auto magnification ratio select (AMS) function in the pamphlet copy mode.
	44	Used to set the model of the unit which is connected to the SCSI I/F of ICU PWB.
50	Used to set YES/NO of black/white reversion is allowed.	
27	1	Used to set the operation specifications when a communication trouble occurs between the host computer and MODEM (on the copier). (When a communication trouble occurs between the host computer and MODEM (copier), the self diag display (U7-00) is printed and setting is made to select inhibit/allow of printing.)
	2	Used to set and change the host computer/MODEM numbers. (This setting is required when a communication is made between the copier and a computer through MODEM.)
	3	Used to set and change the ID numbers of the copier and the host computer/MODEM numbers. (This setting is required when a communication is made between the copier and a computer through MODEM.)
	4	Used to enter the start time and the end time of servicing for management of service work. (The data can be checked by the host computer.)
	5	Used to enter the TAG No. of the copier. (This simulation allows to check the machine TAG No. with the host computer.)

Code		Function (Purpose)
Main	Sub	
30	1	Used to check the operation of sensors and detectors in the paper feed section, the paper transport section, and the paper exit section, and the related circuit.
	2	Used to check the operation of sensors and detectors in the paper feed section and the related circuits. (The operations of sensors and detectors in the paper feed section can be monitored with the LCD.)
40	1	Used to check the operation of the manual paper feed tray paper size detector and the related circuit. (The operation of the manual paper feed tray paper size detector can be monitored with the LCD.)
	2	Used to adjust the manual paper feed tray paper width detector detection level.
41	1	Used to check the operation of the document size sensor and the related circuit. (The operation of the document size sensor can be monitored with the LCD.)
	2	Used to adjust the document size sensor detection level.
	3	Used to check the operation of the document size sensor and the related circuit. (The document size sensor output level can be monitored with the LCD.)
43	1	Used to set the fusing temperature in each operation mode.
	3	Used to adjust the fusing motor speed. (AR-501/505 only)
	8	Used to set the time to rotate the fusing motor after reaching the set temperature in warming up. (AR-501/505 only)
44	1	Used to set whether the correction functions of the image forming (process) section are valid or not.
	2	Used to adjust the sensitivity (gain) of the OPC drum mark sensor and the image density sensor.
	4	Used to set the target image (reference) density level in the developing bias voltage correction.
	5	Used to set various parameters (main charger grid voltage, laser beam power, correction start developing bias voltage) in developing bias correction.
	9	Used to check the data on the result of the image forming section correction (process correction) (the corrected main charger grid voltage in each print mode, developing bias voltage, the laser power, etc.) (This simulation allows to check whether the correction is executed properly or not.)
	12	Used to check the toner image patch density data in correction operation of the image forming section. (This simulation allows to check whether the correction is executed properly or not.)
	15	Used to set the correction values of various parameters (maincharger grid voltage, laser beam power, developing bias voltage) in the image forming operation and image forming section correction for OPC drum type A. (AR-250/280/281/285/286/335/336/405 only)
46	2	Used to adjust the copy density in the copy mode (binary/multi-value - auto, character and photo, photo mode). (The overall print density in each mode (all of the specified density set for each density level (display value)) can be adjusted in each mode.)
	3	Used to adjust the copy density in the copy mode (multi value-auto, character and photo, photo mode). (The overall print density in each mode (all of the specified density set for each density level (display value)) can be adjusted in each mode.) (AR-250/280/285/330/335 only)
	5	Used to adjust the print density for each density level (display value) in the copy mode (multi character mode). An arbitrary print density can be set for each density level (display value). (AR-250/280/285/330/335 only)
	6	Used to adjust the print density for each density level (display value) in the copy mode (multi value-character, photo mode). An arbitrary print density can be set for each density level (display value). (AR-250/280/285/330/335 only)
	7	Used to adjust the print density for each density level (display value) in the copy mode (multi value - photo mode). (Japan only)
	9	Used to adjust the print density for each density level (display value) in the copy mode (binary - character mode).

Code		Function (Purpose)
Main	Sub	
46	10	Used to adjust the print density for each density level (display value) in the copy mode (binary - character, photo mode). An arbitrary print density can be set for each density level (display value).
	11	Used to adjust the print density for each density level (display value) in the copy mode (binary - photo mode). An arbitrary print density can be set for each density level (display value).
	17	Used to execute shading correction and display the correction value.
	18	Used to adjust γ (density gradient) in each copy mode. (Target models: AR-2X1/3X1/4XX/250/XX6/5XX series)
	19	Used to adjust γ (density gradient) and set the density detection area in the auto copy mode and to set the image process mode in the photo copy mode. (Target models: AR-2X1/3X1/4XX/250/XX6/5XX series)
	20	Used to adjust the copy density correction in the SPF (RSPF) copy mode for the document table copy mode. Adjustment is made so that the copy density is the same as that in the document table copy mode. (Target models: AR-2X1/3X1/4XX/250/XX6/5XX series)
48	1	Used to adjust the copy magnification ratio (main scanning direction, sub scanning direction).
50	1	Used to adjust the copy image position and the void area (image loss) on the print paper in the copy mode. (The same adjustment can be made with SIM 50-2 (simple method).)
	2	Used to adjust the copy image position and the void area (image loss) on the print paper in the copy mode. (Simple adjustment) (This simulation allows the same simulation with SIM 50-1 more simply.)
	5	Used to adjust the print image position (top margin) on the print paper in the print mode.
	6	Used to adjust the copy lead edge. (RSPF)
	7	Used to adjust the copy lead edge (simple method). (RSPF)
	10	Used to adjust the print image center position. (Adjustment can be made for each paper feed section.)
	12	Used to adjust the print image center position. (Adjustment can be made for each document mode.)
	51	1
51	2	Used to adjust the contact pressure of paper onto the resist roller in each section (copier paper feed section, duplex paper feed section, SPF paper feed section). (When the print image position varies greatly for the paper or when a lot of paper jam troubles occur, the adjustment is required.)
	8	Used to set Enable/Disable of the drum separation pawl drive solenoid (PSPS) operation for each paper feed section. (AR-501/505 only)
52	1	Used to adjust the duplex print mode stacking capability. (Used to adjust the stop position of the paper tray width direction alignment plate in the duplex unit. The adjustment is executed by changing the width direction alignment plate home position in the software.)
53	1	Used to adjust the document stop position in each operation mode of ADF/RADF. (Target model: AR-250/280/285/335/405)
	2	Used to adjust the optical sensor sensitivity in the ADF/RADF. (Target models: AR-250/280/285/335/405/501/505)
	6	Used to adjust the RSPF width detection level. (AR-501/505 only)
60	1	Used to check the operation (read/write) of ICU (DRAM). (SIMM MEMORY/ONBOARD MEMORY)
61	1	Used to test the operation of the scanner (exposure) unit.
	2	Used to adjust the scanner (exposure) laser power (absolute value) in the copy mode.
	4	Used to adjust the scanner (exposure) laser power (absolute value) in the printer mode. (For Photoconductor type B)

Code		Function (Purpose)
Main	Sub	
62	1	Used to format the hard disk. (Target models: AR-250/280/285/335)(Models with the hard disk installed only)
	2	Used to check the operation (read/write) of the hard disk. (Target models: AR-250/280/285/335)(Models with the hard disk installed only.) (Partial check)
62	3	Used to check the operation (read/write) of the hard disk. (Target models: AR-250/280/285/335) (Only the models with a hard disk) (All area check)
63	1	Used to check the result of shading correction. (The shading correction data are displayed.)
	7	Used to adjust the white plate scanning start position in the shading white correction. (AR-501/505 only)
64	1	Used to check the operation of the printer function (auto print operation). (Print pattern, paper feed mode, print mode, the number of sheets, and the density can be set to an arbitrary value.)
65	1	Used to adjust the touch panel (LCD display) detecting position.
	2	Used to check the result of the touch panel (LCD display) detecting position adjustment. (The coordinates are displayed.)
67	1	Used to check the printer PWB memory operation (read/write). (When replacing the PWB with a new one, this check must be performed.)
	2	Used to check the printer parallel I/F operation. (This simulation is used only for production, and a special tool is required. Not available in the market.)
	3	Used to adjust the printer parallel I/F ACK signal width.
	11	Used to set YES/NO of the printer parallel I/F SELECT IN signal.
	12	Used to write data into the printer flash memory.
	13	Used to check the printer flash memory data.
	14	Used to check the printer flash memory data writing and its result.
	15	Used to check the sum of the printer flash memory.
	16	Used to check the operation of the network card.
	17	Used to clear data in the NVRAM of the printer PWB (set to the default). (Printer set data)
68	1	Used to check the operation of infrared communication I/F (Zaurus link) and the related circuit. (Target models: AR-F230/S280/F280S/F280R/S330)(Japan models only)
69	1	Used to check the input/output by connecting channels A and B of SCSI with the SCSI cable. (AR-501/505 only)

C. Details of simulations

1

1 - 1

Purpose	Operation test/check
Function (Purpose)	Used to check the operation of the scanner unit and its control circuit.
Section	Optical (Image scanning)
Item	Operation
Operation/ Procedure	1. Select the copy (scanning) magnification ratio with the zoom key. The magnification ratio can be increased or decreased with the [ZOOM] key by the increment of 1%. The selected magnification ratio is displayed on the magnification ratio display. 2. Press the [EXECUTE] key. Scanning is performed at the magnification ratio set in procedure 1 is executed. During scanning, the [EXECUTE] key is highlighted. If the [EXECUTE] key is pressed under this state, the operation is interrupted. After completion of scanning, the [EXECUTE] key returns to the normal display. To resume scanning, start with procedure 2. To change the magnification ratio, start with procedure 1. Scanning is performed at the max. scanning length (432mm). If, however, the magnification ratio is set to greater than 100%, the scanning length is changed accordingly.

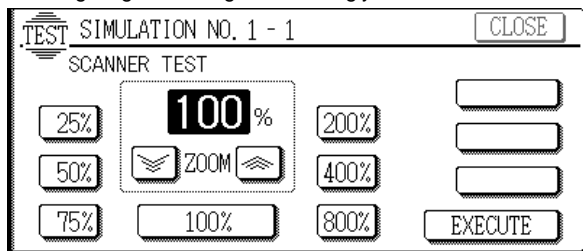

1 - 2

Purpose	Operation test/check
Function (Purpose)	Used to check the operation of sensors and detectors in the scanner section and the related circuit.
Section	Optical (Image scanning)
Item	Operation
Operation/ Procedure	The operations of sensors and detectors in the scanner section are displayed. The active sensors and detectors are highlighted.

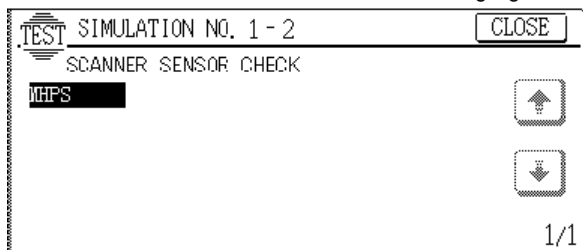

2

2 - 1

Purpose	Operation test/check
Function (Purpose)	Used to check the operation of the RADF unit and its control circuit.
Section	SPF/ADF/RSPF/RADF
Item	Operation
Operation/ Procedure	1. Select the aging mode with the key. When selection is made, the selected item is highlighted. [1:SIDE]: Single copy aging mode [2:SIDE] Duplex copy aging mode (Note) [2:SIDE] is displayed only when the unit which allows duplex copy is installed.

2. Select the copy magnification ratio with the key.
(The magnification ratio can be increased or decreased in the increment of 1% with the [ZOOM] key.)
The selected magnification ratio is displayed on the magnification ratio display on the screen.
The magnification ratio can be set only when SPF is installed.

3. Press the [EXECUTE] key.

Aging of the document feeder is executed under the conditions specified with procedures 1 and 2.

During aging, the [EXECUTE] key is highlighted. If the [EXECUTE] key is pressed while it is highlighted, the operation is interrupted.

When two or more operations are selected in procedure 1, "1:SIDE" (single copy aging mode) is unconditionally performed and the other highlighted displays return to the normal display.

To resume aging, execute with procedure 3.

To change the conditions for aging, execute with procedure 1.

- * When the SPF is installed, the magnification ratio can be adjusted in the range of 64% - 200%.

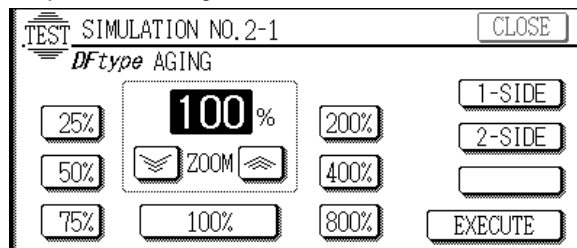

2 - 2

Purpose	Operation test/check
Function (Purpose)	Used to check the operation of sensors and detectors in the RADF units and the related circuit.
Section	SPF/ADF/RSPF/RADF
Item	Operation
Operation/ Procedure	The operations of sensors and detectors in the RADF/ADF/SPF section are displayed. The active sensors and detectors are highlighted.

[ADF/RADF installed]

DSS	Empty sensor	Normal display: Document empty	Highlighted display: Document exist
DFD	Resist sensor	Normal display: Document empty	Highlighted display: Document exist
DTD	Paper timing sensor	Normal display: Document empty	Highlighted display: Document exist

AUOD	DF open/close sensor	Normal display: Close	Highlighted display: Open
TSS1	Tray feed size sensor (large size)	Normal display: Document empty	Highlighted display: Document exist
TSS2	Tray feed size sensor (small size)	Normal display: Document empty	Highlighted display: Document exist
DWS1	Tray width sensor (182mm)	Normal display: OFF	Highlighted display: ON
DWS2	Tray width sensor (210mm/215.9mm)	Normal display: OFF	Highlighted display: ON
DWS3	Tray width sensor (257mm)	Normal display: OFF	Highlighted display: ON
DWS4	Tray width sensor (279.4mm)	Normal display: OFF	Highlighted display: ON
DWS5	Tray width sensor (297mm)	Normal display: OFF	Highlighted display: ON
RDD	Paper exit sensor	Normal display: OFF	Highlighted display: ON

[SPF installed]

DSS empty sensor	Normal display: Document empty	Highlighted display: Document exist
DFD resist sensor	Normal display: Document empty	Highlighted display: Document exist
RDD paper exit sensor	Normal display: Document empty	Highlighted display: Document exist
AUOD DF open/close sensor	Normal display: Close	Highlighted display: Open
TSS1 tray feed size sensor (large size)	Normal display: Document empty	Highlighted display: Document exist
TSS2 tray feed size sensor (small size)	Normal display: Document empty	Highlighted display: Document exist
DWS1 tray width sensor (182mm)	Normal display: OFF	Highlighted display: ON
DWS2 tray width sensor (210mm/215.9mm)	Normal display: OFF	Highlighted display: ON
DWS3 tray width sensor (257mm)	Normal display: OFF	Highlighted display: ON
DWS4 tray width sensor (279.4mm)	Normal display: OFF	Highlighted display: ON
DWS5 tray width sensor (297mm)	Normal display: OFF	Highlighted display: ON

[RSPF installed]

EMP	Empty sensor	Normal display: Document empty	Highlighted display: Document exist
BUNRIS	Post-separation sensor	Normal display: Document empty	Highlighted display: Document exist
RDS	Read sensor	Normal display: Document empty	Highlighted display: Document exist
RDD	Paper exit sensor	Normal display: Document empty	Highlighted display: Document exist
SBS	Switch-back sensor	Normal display: Document empty	Highlighted display: Document exist
REGS	Resist sensor	Normal display: Document empty	Highlighted display: Document exist
AUOD	DF open/close sensor	Normal display: Close	Highlighted display: Open
FGOD	Paper feed cover sensor	Normal display: Close	Highlighted display: Open
TSS1	Tray feed size sensor (large size)	Normal display: Document empty	Highlighted display: Document exist
TSS2	Tray feed size sensor (small size)	Normal display: Document empty	Highlighted display: Document exist

DWS1	Tray width sensor (182mm)	Normal display: OFF	Highlighted display: ON
DWS2	Tray width sensor (210mm/8.5")	Normal display: OFF	Highlighted display: ON
DWS3	Tray width sensor (257mm)	Normal display: OFF	Highlighted display: ON
DWS4	Tray width sensor (17")	Normal display: OFF	Highlighted display: ON
DWS5	Tray width sensor (297mm)	Normal display: OFF	Highlighted display: ON

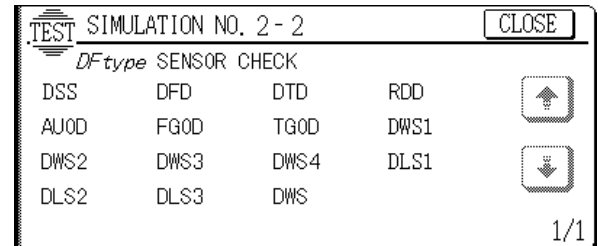
**2 - 3**

Purpose	Operation test/check
Function (Purpose)	Used to check the operation of the loads in the RADF/ADF/SPF units and the control circuits.
Section	SPF/ADF/RSPF/RADF
Item	Operation
Operation/ Procedure	1. The names of the loads which can be operated are displayed. Select the load to be checked with the key, and the selected load is highlighted.

2. Press the [EXECUTE] key.

The load selected in procedure 1 starts the operation. During the operation of the load, the [EXECUTE] key is highlighted. If the EXECUTE key is pressed while it is highlighted, the operation is stopped.

When two or more operations are selected in procedure 1, the operation is performed in the sequence of display order.

[When ADF/RADF is installed]

DFM FORWARD	Paper feed motor forward rotation
DFM REVERSE	Paper feed motor reverse rotation
DTM FORWARD	Transport motor forward rotation
DTM REVERSE	Transport motor reverse rotation
DRM	Paper expulsion motor
DFSOL	Paper feed solenoid

[When SPF is installed]

DTM FORWARD	Transport motor forward rotation
DTM REVERSE	Transport motor reverse rotation
STAMP SOL	Stamp solenoid

[When RSPF is installed]

DFM FORWARD (L)	Paper feed motor forward rotation (230mm/sec)
DFM REVERSE (L)	Paper feed motor reverse rotation (360mm/sec)
DFM FORWARD (H)	Paper feed motor forward rotation (450mm/sec)
DFM REVERSE (H)	Paper feed motor reverse rotation (450mm/sec)
DTM	Transport pulse motor
DFC	Paper feed clutch
FSOL1	Flapper solenoid 1
FSOL2	Flapper solenoid 2
SBSOL	Switchback pressure solenoid

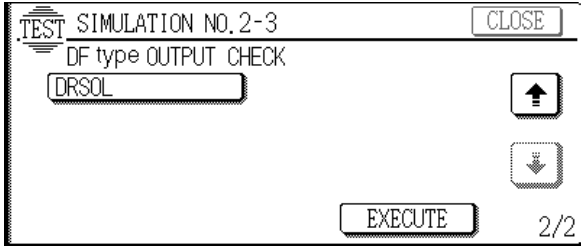
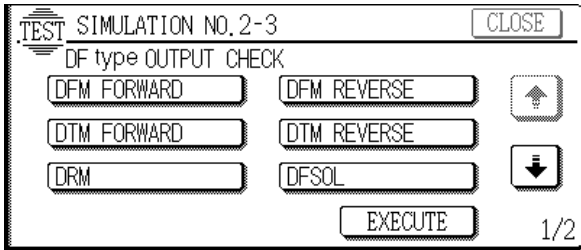

3

3 - 2

Purpose	Operation test/check
Function (Purpose)	Used to check the operation of sensors and detectors in the sorter and the related circuit.
Section	Sorter/Finisher
Item	Operation
Operation/Procedure	The display differs depending on the unit (sorter, finisher) installed. The operations of the sensors and detectors in the sorter and the finisher section are displayed. The active sensors and detectors are highlighted.

EVRE	Elevator motor encoder
OFHP	Offset home sensor
STHP	Staple home sensor
INPD	Paper entry sensor
RVPD	Reverse paper exit sensor
PGOP	Upper transport PG open/close sensor
PFD1	Transport sensor 1
PFD2	Transport sensor 2
PFD3	Transport sensor 3
PFD4	Transport sensor 4
T3OD	Tray 3 paper exit sensor
STID	Staple tray paper entry sensor
STPD	Staple paper sensor
T1PF	Tray 1 paper full sensor
T3UP	Tray 3 upper limit sensor
T3DN	Tray 3 lower limit sensor
LSTS	Stapler sensor
NCTS	Staple cartridge sensor
PWD	Power off detection
DSW1	Copier connection detection
DSW2	Top door open/close detection
DSW3	Front door open/close detection

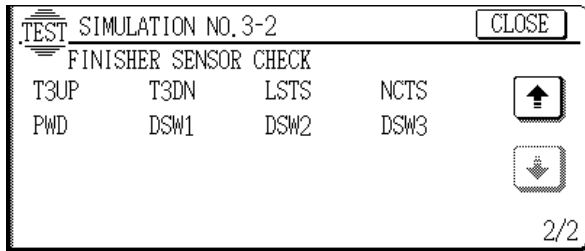
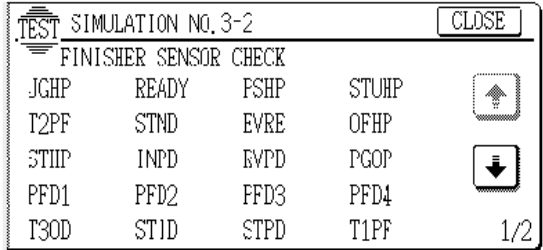

In the case of AR-SS1

PIS	Paper entry port sensor
PSFT	Paper empty sensor
THLS	Upper limit sensor
TLLS	Lower limit sensor
THPS	Bin home sensor
PSFT0	Take-out position sensor
SPHPS	Alignment rod home sensor
CHPS	Holder home sensor
SHPSW	Stapler home switch
PSFSU	Stapler paper sensor
SSFSU	Stapler empty sensor
SSSW	Joint section door sensor
SCSW	Staple unit section door sensor

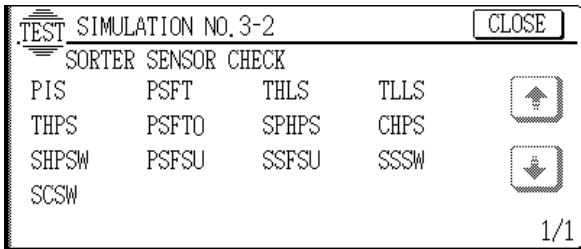

In the case of AR-FN1

JGHP	Jogger motor home sensor
READY	Stapler self priming sensor
PSHP	Pusher motor home sensor
STUHP	Staple unit home sensor
T2PF	Tray 2 paper full sensor
STND	Stapler replacement sensor

In the case of AR-FN2/FN3

JGHP	Jogger motor home sensor
READY	Stapler self priming sensor
PSHP	Pusher motor home sensor
STORHP	ST paper exit roller pressure release clutch home sensor
STUHP	Staple unit home sensor
T2PF	Tray 2 paper full sensor
STND	Stapler replacement sensor
EVRE	Elevator motor encoder
OFHP	Offset home sensor
STHP	Staple home sensor
INPD	Paper entry sensor
T3PDHP	Tray 3 paper exit roller paddler home sensor
PFD2	Transport sensor 2
PFD3	Transport sensor 3
PFD4	Transport sensor 4
T3OD	Tray 3 paper exit sensor
STID	Staple tray paper entry sensor
STPD	Staple paper sensor
T1PF	Tray 1 paper full sensor
STID2	Staple tray paper-in sensor
T3UP	Tray 3 upper limit sensor

T3DN	Tray 3 lower limit sensor
LSTS	Stapler sensor
NCTS	Staple cartridge sensor
PWD	Power off detection
DSW1	Copier connection detection
DSW2	Top door open/close detection
DSW3	Front door open/close detection

TEST SIMULATION NO. 3-2 CLOSE

FINISHER SENSOR CHECK

JGHP	READY	PSHP	STORHP	↑
STUHP	T2PF	STND	EVRE	
OFHP	STHP	INPD	T3PDHP	↓
PFD2	PFD3	PFD4	T3OD	
STID	STPD	T1PF	STID2	1/2

TEST SIMULATION NO. 3-2 CLOSE

FINISHER SENSOR CHECK

T3UP	T3DN	LSTS	NCTS	↑
PWD	DSW1	DSW2	DSW3	

2/2

3 - 3

Purpose	Operation test/check
Function (Purpose)	Used to check the operation of the loads in the sorter and the control circuit.
Section	Sorter/Finisher
Item	Operation
Operation/Procedure	The display differs depending on the unit (sorter, finisher) which is installed.

- The names of the loads which can be operated are displayed. The selected load is highlighted.
- Press the [EXECUTE] key, and the selected load is operated. During the operation of the load, the [EXECUTE] key is highlighted. If the [EXECUTE] key is pressed when it is highlighted, the operation is interrupted.

In the case of AR-SS1

DTM	Transport motor
DCM	Holder motor
BZ	Buzzer
TMM	Bin shift motor
DSM	Alignment motor
SAM	Stapler drive motor

TEST SIMULATION NO. 3-3 CLOSE

SORTER OUTPUT CHECK

DTM	DCM	BZ	TMM	↑
DSM	SAM			

EXECUTE 1/1

In the case of AR-FN1

PSM	Pusher motor
JGM	Jogger motor
STUM	Staple unit shift motor
FML	Main drive motor low transport speed

FMH	Main drive motor high transport speed
RVM	Reverse motor
EVM	Elevator motor
OFM	Offset motor
INGSL	Paper entry gate solenoid
T3UPSL	Tray 3 upper limit solenoid
OG1SL	Paper exit gate 1 solenoid
OG2SL	Paper exit gate 2 solenoid
OG3SL	Paper exit gate 3 solenoid
RRSL	Reverse roller pressure release solenoid
SPSL	Short path select solenoid
STSL	ST paper holding solenoid
T12CL	Tray 1 and tray 2 speed reduction clutch
PDCL	Paddler clutch
STOPCL	ST paper exit roller pressure clutch
T3SLCL	Tray 3 speed reduction clutch
STM	Staple motor
T3ORSL	Tray 3 normal speed clutch

TEST SIMULATION NO. 3-3 CLOSE

FINISHER OUTPUT CHECK

PSM	JGM	STUM	FML	↑
FMH	RVM	EVM	OFM	
INGSL	T3UPSL	OG1SL	OG2SL	↓

EXECUTE 1/2

TEST SIMULATION NO. 3-3 CLOSE

FINISHER OUTPUT CHECK

OG3SL	RRSL	SPSL	STSL	↑
T12CL	PDCL	STORCL	WLCL	
STM				↓

EXECUTE 2/2

In the case of AR-FN2/FN3

PSM	Pusher motor
JGM	Jogger motor
STUM	Staple unit shift motor
FM	Main drive motor
T3OM	Tray 3 paper exit drive motor
EVM	Elevator motor
OFM	Offset motor
T3PDSL	Tray 3 paper exit paddler solenoid
STPDSL	ST paddler solenoid
OG1SL	Paper exit gate 1 solenoid
OG2SL	Paper exit gate 2 solenoid
OG3SL	Paper exit gate 3 solenoid
STSL	ST paper holding solenoid
T12CL	Tray 1 and tray 2 speed reduction clutch
PDCL	Paddler clutch
STOPCL	ST paper exit roller pressure clutch
STM	Staple motor
PPSL	Paper holding solenoid

TEST SIMULATION NO. 3-3 CLOSE

FINISHER OUTPUT CHECK

PSM	JGM	STUM	FM	↑
T3OM	EVM	OFM	T3PDSL	
STPDSL	OG1SL	OG2SL	OG3SL	↓

EXECUTE 1/2

TEST SIMULATION NO. 3-3		CLOSE
FINISHER OUTPUT CHECK		
STSL	T12CL	PDCL
STORCL	↑	
STM	PPSL	↓
EXECUTE		2/2

3 - 6

Purpose	Adjustment
Function (Purpose)	Used to adjust the finisher stacking capability. (Used to adjust the stop position of the finisher paper width direction alignment plate (jogger). This adjustment is made by changing the width direction alignment plate home position by the software.)
Section	Sorter/Finisher
Item	Operation
Operation/Procedure	<ol style="list-style-type: none"> 1. Select B mode with [↑] and [↓] keys. 2. Select the paper size by entering the numbers (0 or 1) with the 10-key pad. 3. Select A mode with [↑] and [↓] keys. 4. Enter the adjustment value with the 10-key pad. 5. Press the [EXECUTE] key. <p>The value entered in procedure 4 is set.</p> <p>The finisher's jogger starts operation. During operation, the [EXECUTE] key is highlighted.</p> <p>If the [EXECUTE] key is pressed while it is highlighted, the load operation is interrupted.</p>

TEST SIMULATION NO. 3-6		CLOSE
FINISHER JOGGER ADJUSTMENT VALUE		
A: 50	A: 50 ;ADJUST VALUE	↑
[45~55]	B: 0 ;(0:A4, 1:LT)	↓
EXECUTE		

4**4 - 2**

Purpose	Operation test/check
Function (Purpose)	Used to check the operation of sensors and detectors in the paper feed section (desk feed, large capacity tray) and the related circuit.
Section	Paper transport
Item	Operation
Operation/Procedure	<p>The operating conditions of the sensors and detectors in the paper feed section are displayed.</p> <p>The active sensors and detectors are highlighted.</p>

Desk Unit Sensor

DDOPSW	Door open sensor
DPOD1	Paper exit transport sensor 1cs
DPOD2	Paper exit transport sensor 2 cs
DPOD3	Paper transport sensor 3cs
DLUD1	1cs Lift upper limit sensor
DPED1	1cs Paper empty sensor
DCSPD1	1cs remaining quantity detection 1
DLUD2	2xs lift upper limit sensor

DPED2	2cs paper empty sensor
DCSPD2	2cs remaining quantity detection 1
DLUD3	3cs lift upper limit sensor
DPED3	3cs paper empty sensor
DCSPD3	3cs remaining quantity detection 1
FOUND1	1cs lift unit detection (Installation detection)
FOUND2	2cs lift unit detection (Installation detection)
FOUND3	3cs lift unit detection (Installation detection)
DCSS11	1cs size detection 0
DCSS12	1cs size detection 1
DCSS13	1cs size detection 2
DCSS14	1cs size detection 3
DCSS21	2cs size detection 0
DCSS22	2cs size detection 1
DCSS23	2cs size detection 2
DCSS24	2cs size detection 3
DCSS31	3cs size detection 0
DCSS32	3cs size detection 1
DCSS33	3cs size detection 2
DCSS34	3cs size detection 3

LCC Unit Sensor

LRE	Remaining quantity sensor
LUD	Upper limit sensor
LDD	Lower limit sensor
LPED	Paper empty sensor
LPFD	Paper exit sensor
LDSW	Door open SW
LTOD	Body connection sensor
LCD	Cassette detection line

TEST SIMULATION NO. 4-2		CLOSE
DESK LCC SENSOR CHECK		
DDOPSW	DPOD1	IPOD2
DLUD1	DPED1	ICSPD1
DLUD2	DPED2	ICSPD2
DLUD3	DPED3	ICSPD3
FOUND1	FOUND2	FOUND3
EXECUTE		1/2

TEST SIMULATION NO. 4-2		CLOSE
DESK LCC SENSOR CHECK		
DCSS11	DCSS12	DCSS13
DCSS21	DCSS22	DCSS23
DCSS31	DCSS32	DCSS33
LRE	LUD	LDD
LPFD	LDSW	LTOD
EXECUTE		2/2

4 - 3

Purpose	Operation test/check
Function (Purpose)	Used to check the operation of the loads in the paper feed section (desk paper feed, large capacity tray) and the control circuits.
Section	Paper transport
Item	Operation
Operation/Procedure	<ol style="list-style-type: none"> 1. The names of the loads which can be operated are displayed. Select the load to be checked with the key, and the selected load is highlighted. 2. Press the [EXECUTE] key. <p>The load selected in procedure 1 starts the operation.</p>

During the operation of the load, the [EXECUTE] key is highlighted. If the [EXECUTE] key is pressed while it is highlighted, the operation is stopped.

Desk Unit Output

DM	Transport motor
DLUM1	Lift up motor 1
DLUM2	Lift up motor 2
DLUM3	Lift up motor 3
DPFS1	Paper feed solenoid 1
DPFS2	Paper feed solenoid 2
DPFS3	Paper feed solenoid 3
DPFC1	Paper feed clutch 1
DPFC2	Paper feed clutch 2
DPFC3	Paper feed clutch 3
DTRC	Transport clutch

Lcc Unit Output

LLED	Dorr open LED
LPFC	Paper feed clutch
LPFS	Paper feed solenoid
LPFM	Transport motor
LLM	Lift motor

The LCC unit lit motor continues lifting up and falling down

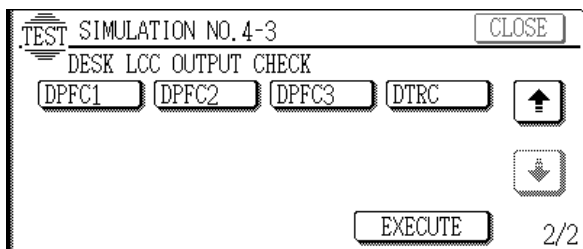
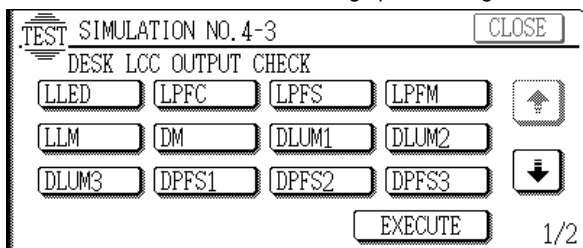

5

5 - 1

Purpose	Operation test/check
Function (Purpose)	Used to check the operation of the display, LCD in the operation panel, and control circuit.
Section	Operation (Display/Operation key)
Item	Operation
Operation/ Procedure	The LCD shows the following message. (The contrast changes in the sequence of Current level → MAX → MIN → Current level → MAX → MIN in every 2sec.)

During that period, each LED is lighted for 2sec.

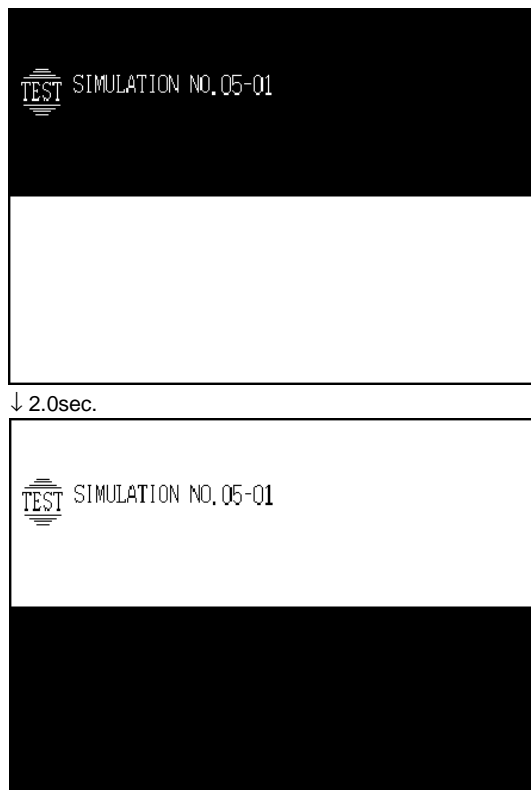

5 - 2

Purpose	Operation test/check
Function (Purpose)	Used to check the operation of the heater lamp and the control circuit.
Section	Fixing (Fusing)
Item	Operation
Operation/ Procedure	1. Select the lamp to be checked with the key. 2. Press the [EXECUTE] key.

The selected heater lamp repeats ON/OFF in the frequency of 500msec 5 times.

Then the [EXECUTE] key returns to the original display.

When the [EXECUTE] key is pressed during ON/OFF operation of the heater lamp, the heater lamp is turned OFF and the [EXECUTE] key returns to the original display.

HL1 (LEFT): This lamp is on the left when viewed from the front and it heats the center of the lamp.

HL2 (RIGHT): This lamp is on the right when viewed from the front and it heats both ends of the lamp.

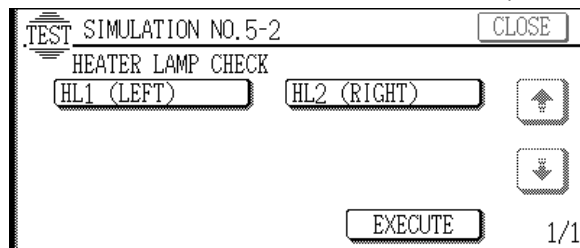

5 - 3

Purpose	Operation test/check
Function (Purpose)	Used to check the operation of the copy lamp and the control circuit.

Section	Optical (Image scanning)
Item	Operation
Operation/Procedure	When the [EXECUTE] key is pressed, the copy lamp is lighted for 10 sec. While the copy lamp is lighted, the [EXECUTE] key is highlighted. If the [EXECUTE] key is pressed under this state, the lamp is turned OFF.

After 10 sec, the copy lamp is turned OFF. At that time, the [EXECUTE] key returns to the normal display.

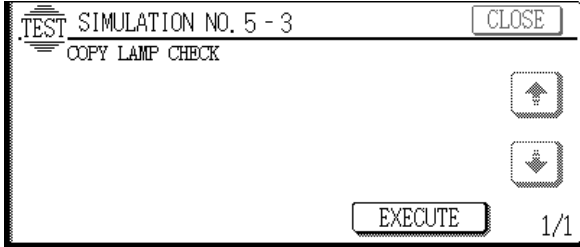

5 - 4

Purpose	Operation test/check
Function (Purpose)	Used to check the operation of the discharge lamp and the control circuit.
Section	Image process Others (Photoconductor/Developing/Transfer/Cleaning)
Item	Operation
Operation/Procedure	When the [EXECUTE] key is pressed, the key is highlighted and the discharge lamp is lighted.

After 30 sec of lighting, the lamp is turned OFF and the [EXECUTE] key returns to the normal display.

If the [EXECUTE] key is pressed while the lamp is lighted, the lamp is turned OFF and the [EXECUTE] key returns to the normal display.

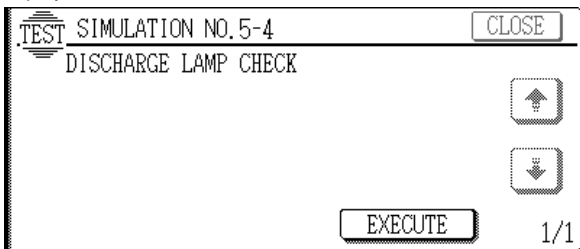

5 - 6

Purpose	Operation test/check
Function (Purpose)	Used to check the operation of the separation lamp and its control circuit. (AR-501/505 only)
Section	Process (OPC drum, developing unit, transfer, cleaning) section
Item	Operation
Operation/Procedure	When the [EXECUTE] key is pressed, it is highlighted and the separation lamp is lighted.

After 30sec of lighting, the lamp turns off and the [EXECUTE] key returns to the normal display.

When the [EXECUTE] key is pressed during the lamp is lighted, the lamp is turned off and the [EXECUTE] key returns to the normal display.

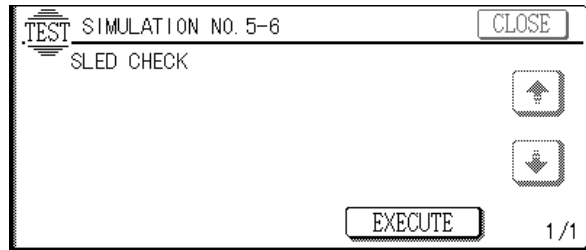

6

6 - 1

Purpose	Operation test/check
Function (Purpose)	Used to check the operation of the loads (clutches and solenoids) in the paper transport system and the control circuit.
Section	Paper transport (Discharge/Switchback/Transport)
Item	Operation
Operation/Procedure	1. The names of the loads which can be operated are displayed. Select the load to be checked with the key, and the selected load is highlighted.

- Press the [EXECUTE] key.
The selected load starts the operation.
During the operation of the load, the [EXECUTE] key is highlighted.
If the [EXECUTE] key is pressed while it is highlighted, the operation is stopped.

CPFC1	Upper cassette paper feed clutch
CPFS1	Upper cassette paper feed solenoid
LUM1	Lower cassette lift up motor
CPFC2	Lower cassette paper feed clutch
CPFS2	Lower cassette paper feed solenoid
LUM2	Lower cassette lift up motor
MPFC	Manual paper feed clutch
MPFS	Manual paper feed solenoid
MSS	Manual paper entry gate solenoid
TRC1H	Transport clutch 1 high speed
TRC1L	Transport clutch 1 low speed
MTRC	Transport clutch low speed
TRC2	Transport clutch 2 high speed
RRC	Resist roller clutch
OGS	Paper exit gate solenoid
DSBS	Duplex unit paper entry switchback gate solenoid
PSPS	Separation pawl operation solenoid
SBM FW	Switchback motor forward rotation
SBM RV	Switchback motor reverse rotation

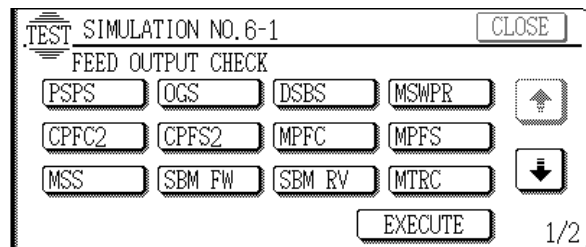

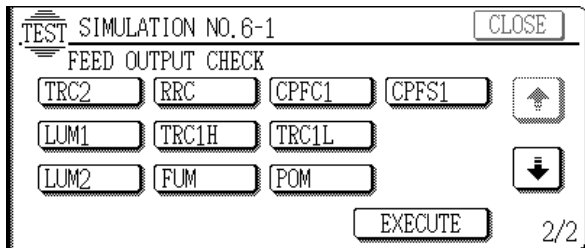

6 - 2

Purpose	Operation test/check
Function (Purpose)	Used to check the operation of each fan motor and its control circuit.
Section	Others
Item	Operation
Operation/ Procedure	1. The names of the loads which can be operated are displayed. Select the load to be checked with the key, and the selected load is highlighted.

2. Press the [EXECUTE] key.
The key is highlighted and the selected fan motor is rotated.
If the [EXECUTE] key is pressed while the fan motor is rotating, the [EXECUTE] key returns to the normal display and the fan motor is stopped. To operate or stop each fan motor, press the key of the fan motor.
However, [CFM Low] key and [CFM High] key cannot be pressed ON simultaneously.

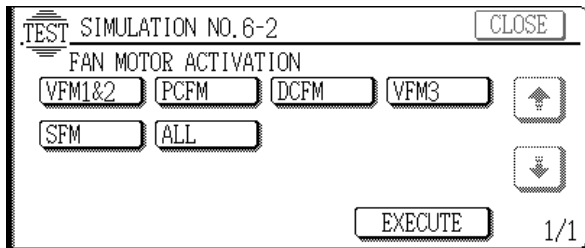

7

7 - 1

Purpose	Setting/Operation test/check
Function (Purpose)	Used to set the aging operation conditions.
Item	Operation
Operation/ Procedure	1. Press each corresponding key to set for the aging operation. (Set items of each key)

[AGING]	Aging setting
[MISFEED DISABLE]	Jam detection enable/disable setting
[FUSING DISABLE]	Fusing operation enable/disable setting
[WARMUP DISABLE]	Warm-up save setting
[INTERVAL]	Intermittent setting (Valid only in [AGING] setting)
[DV CHECK DISABLE]	Developing unit detection enable/disable setting
[SHADING DISABLE]	Shading enable/disable setting

The selected key is highlighted.

2. Press the [EXECUTE] key.
Aging is set and the display returns to the simulation main code entry display.
* When this simulation is executed, the machine resumes operation regardless of setting (changing) of aging.

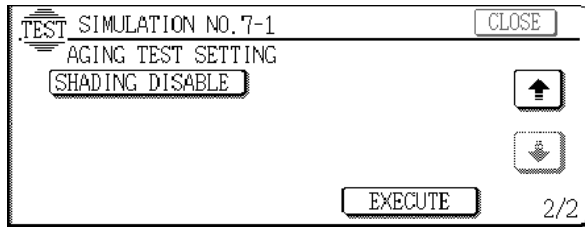
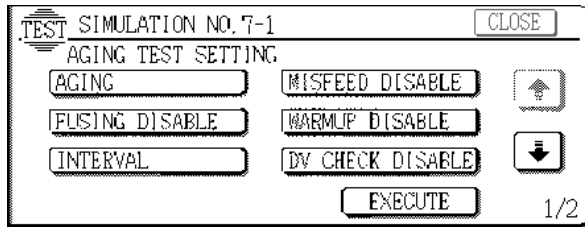

7 - 6

Purpose	Setting/Operation test/check
Function (Purpose)	Used to set the cycle of intermittent aging.
Item	Operation
Operation/ Procedure	1. Enter the interval aging cycle time (sec) with the 10-key pad. 2. Press [OK] key to set the entered cycle time.

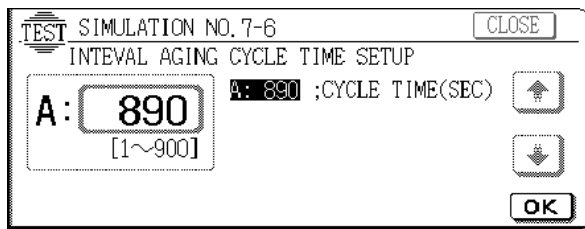

7 - 8

Purpose	Setting/Operation test/check
Function (Purpose)	Used to set YES/NO of display of the warmup time.
Item	Operation
Operation/ Procedure	Press the [EXECUTE] key to set the warmup time display. When the [EXECUTE] key is pressed, the warmup time display setting is executed and the display returns to the simulation main code entry display.

- * When this simulation is canceled after completion of it, the machine resumes operation regardless of setting (changing) of warmup time display.

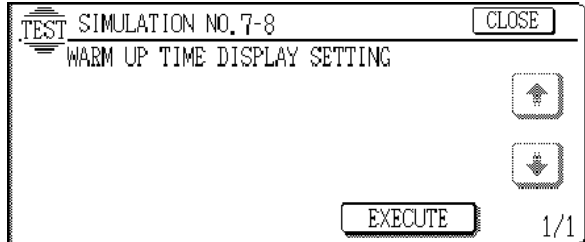

After completion of warming up, the warm-up time is displayed.

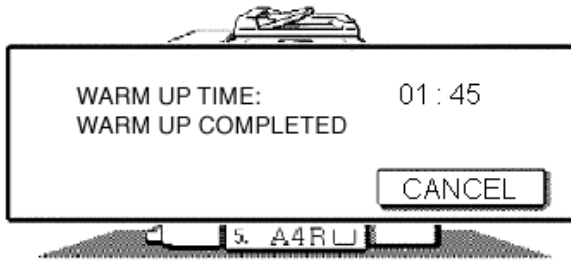

8

8 - 1

Purpose	Adjustment/Operation test/check
Function (Purpose)	Used to check the operation of the developing bias voltage in each print mode and its control circuit. (For OPC drum type B)
Section	Process (OPC drum, developing unit, transfer, cleaning) section
Operation/Procedure	(The developing bias output voltage of each print mode can be adjusted and checked.)

1. Select the print mode with [↑] key and [↓] key.
2. Enter the adjustment value with the 10-key pad.
3. Press the [EXECUTE] key.

The [EXECUTE] key is highlighted, the adjustment value entered in procedure 2 is set, and the voltage corresponding to the set value is supplied.

After supplying the voltage for 30 sec, the [EXECUTE] key returns to the normal display.

If the [EXECUTE] key is pressed while the voltage is supplied, the voltage output is stopped and the [EXECUTE] key returns to the normal display.

(AR-250/280/281/285/286/335/336/405)

AUTO	: Auto mode	* (500) (-500V ±5V)
CHARA	: Character mode	* (500) (-500V ±5V)
CHARA PHOTO	: Character/Photo mode	* (500) (-500V ±5V)
PHOTO	: Photo mode	* (500) (-500V ±5V)
TONER SAVE	: Toner save mode	* (500) (-500V ±5V)
PRINTER	: Printer mode	* (500) (-500V ±5V)
PLUS	: Cleaning mode	* (150) (+150V ±5V)

Developing bias voltage

* () : Default

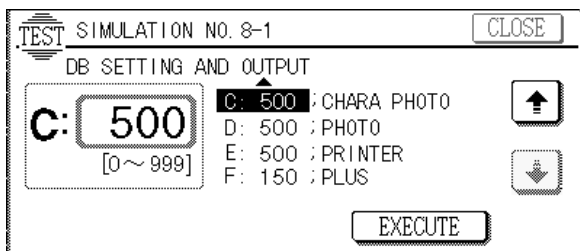
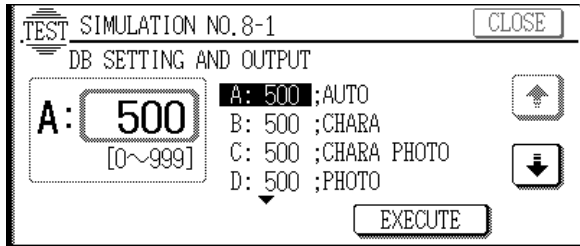

(AR-501/505)

AUTO	: Auto mode	* (415) (-425V ±5V)
CHARA	: Character mode	* (490) (-500V ±5V)
CHARA PHOTO	: Character/Photo mode	* (490) (-500V ±5V)
PHOTO	: Photo mode	* (490) (-500V ±5V)
TONER SAVE	: Toner save mode	* (490) (-500V ±5V)
PRINTER	: Printer mode	* (490) (-500V ±5V)
PLUS	: Cleaning mode	* (165) (+150V ±5V)

Developing bias voltage

* () : Default

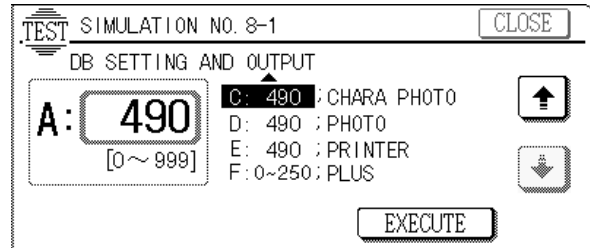
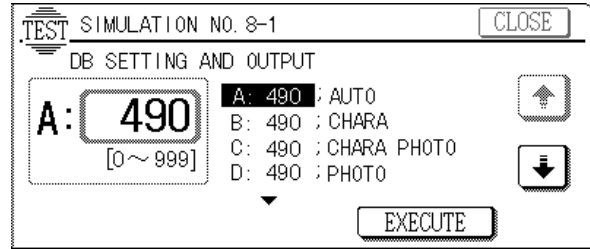

8 - 2

Purpose	Adjustment/Operation test/check
Function (Purpose)	Used to check and adjust the operation of the main charger grid voltage in each print mode and the control circuit. (for OPC drum type B)
Section	Image process (Photoconductor/Developing/Transfer/Cleaning)
Operation/Procedure	(The charging/grid output voltage in each print mode can be adjusted and checked.)

1. Select the print mode with [↑] key and [↓]key.
2. Enter the adjustment value with the 10-key pad.
3. Press the [EXECUTE] key.

The [EXECUTE] key is highlighted, the adjustment value entered in procedure 2 is set, and the voltage corresponding to the set value is supplied.

After supplying the voltage for 30 sec, the [EXECUTE] key returns to the normal display.

If the [EXECUTE] key is pressed while the voltage is supplied, the voltage output is stopped and the [EXECUTE] key returns to the normal display.

(AR-250/280/281/285/286/335/336/405)

AUTO	: Auto mode	* (641) (-642 ±5V)
CHARA	: Character mode	* (641) (-642 ±5V)
CHARA PHOTO	: Character/Photo mode	* (641) (-642 ±5V)
PHOTO	: Photo mode	* (641) (-642 ±5V)
PRINTER	: Printer mode	* (641) (-642 ±5V)

* () : Default

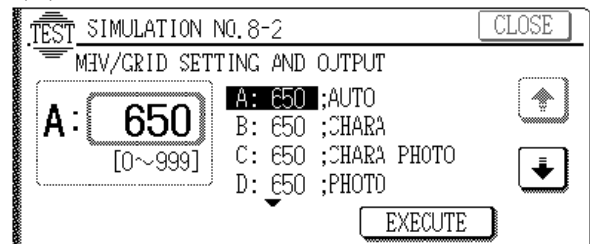

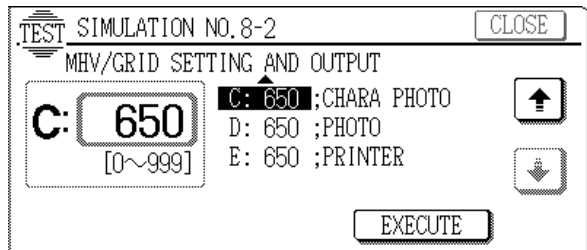

(AR-501/505)

- AUTO : Auto mode * (560) (-570 ±5V)
- CHARA : Character mode * (635) (-645 ±5V)
- CHARA PHOTO : Character/Photo mode * (635) (-645 ±5V)
- PHOTO : Photo mode * (635) (-645 ±5V)
- PRINTER : Printer mode * (635) (-645 ±5V)

* () : Default

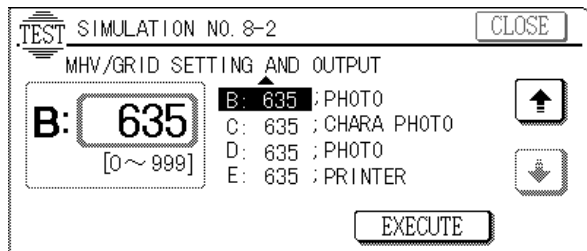
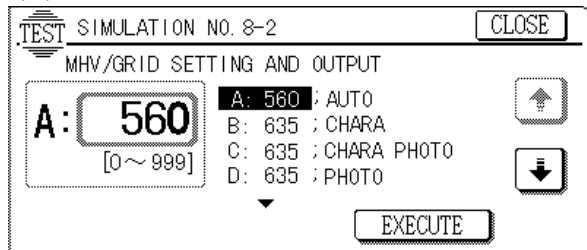

8 - 6

Purpose	Adjustment/Operation test/check
Function (Purpose)	Used to check and adjust the transfer charger current and the control circuit.
Section	Image process Copy (Photoconductor/Developing/Transfer/Cleaning)
Operation/Procedure	The transfer charger output voltage in printing the front and the back of paper can be adjusted and checked.

1. Select the print mode with [↑] key and [↓] key.
2. Enter the adjustment value with the 10-key pad.
3. Press the [EXECUTE] key.

The [EXECUTE] key is highlighted, the adjustment value entered in procedure 2 is set, and the voltage corresponding to the set value is supplied.

After supplying the voltage for 30 sec, the [EXECUTE] key returns to the normal display.

If the [EXECUTE] key is pressed while the voltage is supplied, the voltage output is stopped and the [EXECUTE] key returns to the normal display.

FRONT MODE: Front surface print (with the paper feed tray and manual paper feed tray)

BACK MODE: Back surface print (with duplex paper feed)

(AR-250/280/281/285/286/335/336/405)

Default: 140 (13.5 + 1.5µA)

(AR-501/505)

Default: 255 (18.0 + 1.5µA)

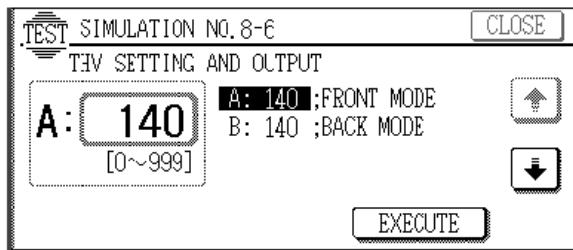

8 - 7

Purpose	Adjustment/Operation test/check
Function (Purpose)	Used to check and adjust the operation of the separation charger voltage and its control circuit.
Section	Image process Others (Photoconductor/Developing/Transfer/Cleaning)
Operation/Procedure	The separation charger output voltage in printing the front and the back of paper can be adjusted and checked.

1. Select the print mode with [↑] key and [↓] key.
2. Enter the adjustment value with the 10-key pad.
3. Press the [EXECUTE] key.

The [EXECUTE] key is highlighted, the adjustment value entered in procedure 2 is set, and the voltage corresponding to the set value is supplied.

After supplying the voltage for 30 sec, the [EXECUTE] key returns to the normal display.

If the [EXECUTE] key is pressed while the voltage is supplied, the voltage output is stopped and the [EXECUTE] key returns to the normal display.

FRONT MODE: Front surface print (with the paper feed tray and manual paper feed tray)

BACK MODE: Back surface print (with duplex paper feed)

(AR-250/280/281/285/286/335/336/405)

Default: 90 (DC -140 ±10V)

(AR-501/505)

Default: 177 (DC -200 ±10V)

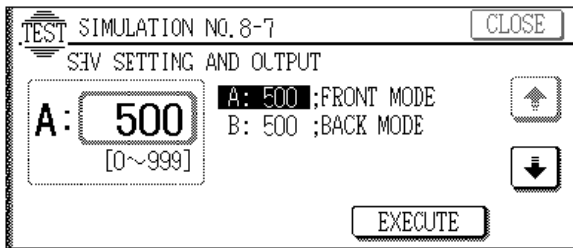

9

9 - 1

Purpose	Operation test/check
Function (Purpose)	Used to check the operation of the loads (clutches and solenoids) in the duplex section and the control circuit.
Section	Duplex
Item	Operation
Operation/Procedure	1. Select the load to be checked with the key. The selected key is highlighted.

2. Press the [EXECUTE] key.
The load selected in procedure 1 is operated.

While the load is operated, the [EXECUTE] key is highlighted.
If the [EXECUTE] key is pressed under this state, the load operation is interrupted.

DTC1	Duplex unit paper entry transport clutch 1
DTC2	Duplex unit paper entry transport clutch 2
DSCS	Duplex unit roller contact solenoid

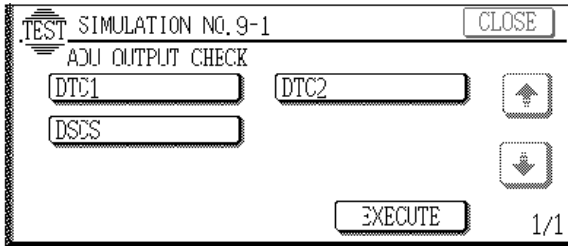
**9 - 2**

Purpose	Operation test/check
Function (Purpose)	Used to check the operation of sensors and detectors in the duplex section and the control circuit.
Section	Duplex
Item	Operation
Operation/ Procedure	The operations of sensors and detectors in the duplex section are displayed.

The active sensors and detectors are highlighted.

DSBD	Duplex unit paper entry switchback section sensor
DPPD1	Duplex unit paper transport switch 1
DPPD2	Duplex unit paper transport switch 2
DPPD3	Duplex unit paper transport switch 3
DPAD	Duplex unit alignment plate home sensor

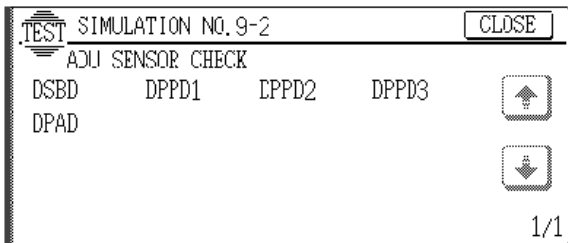
**9 - 4**

Purpose	Operation test/check
Function (Purpose)	Used to check the operation of the duplex unit alignment plate and its control circuit.
Section	Duplex
Item	Operation
Operation/ Procedure	1. Select the paper size. The selected paper size is highlighted.

2. Press the [EXECUTE] key.

Alignment operation is continuously operated.

During the operation, the [EXECUTE] key is highlighted.

If the [EXECUTE] key is pressed under this state, the operation is interrupted.

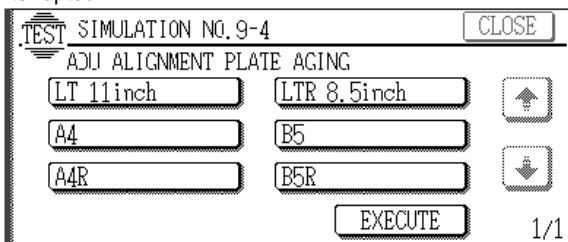
**10****10 - 0**

Purpose	Operation test/check
Function (Purpose)	Used to check the operation of the toner motor and its control circuit. (Note) Do not execute this simulation with toner in the toner hopper. If executed, excessive toner may enter the developing section, causing an overtone trouble. Be sure to remove the toner motor from the toner hopper before executing this simulation.
Section	Image process (Photoconductor/Developing/Transfer/Cleaning)
Item	Developer/Toner Hopper
Operation/ Procedure	When the [EXECUTE] key is pressed, it is highlighted and the toner motor rotates for 10 sec.

After 10sec of rotation, the toner motor stops and the [EXECUTE] key returns to the normal display.

If the [EXECUTE] key is pressed during rotation, the toner motor is stopped and the [EXECUTE] key returns to the normal state.

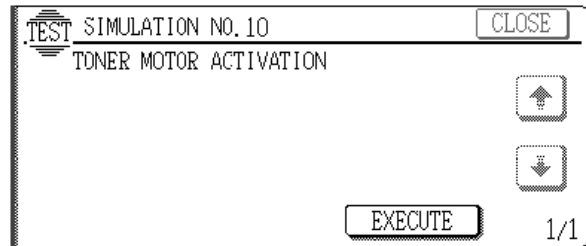
**13****13 - 0**

Purpose	Clear/Cancel (Trouble etc.)
Function (Purpose)	Used to cancel the self diag U1 trouble.
Item	Trouble
Operation/ Procedure	When the [EXECUTE] key is pressed, the U1 trouble is canceled and the display returns to the simulation main code entry screen. After this simulation is canceled, the machine resumes operation.

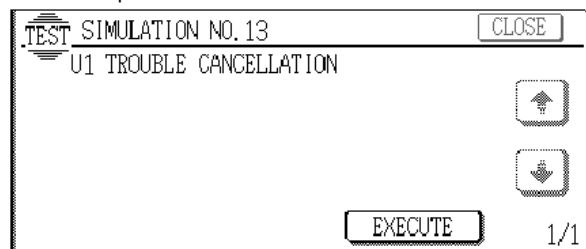
**14****14 - 0**

Purpose	Clear/Cancel (Trouble etc.)
Function (Purpose)	Used to cancel the self diag U1/LOC/U2/PF troubles.

Item	Trouble	Error
Operation/Procedure	When the [EXECUTE] key is pressed, the troubles excluding U1/LCC/U2/PF are canceled and the display returns to the simulation main code entry screen. After this simulation is canceled, the machine resumes operation.	

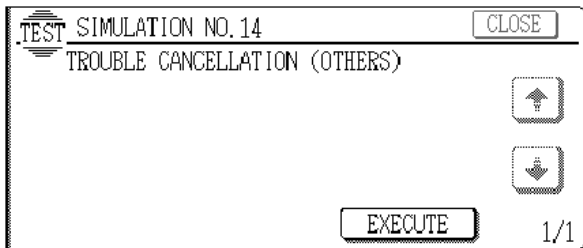

15

15 - 0

Purpose	Clear/Cancel (Trouble etc.)
Function (Purpose)	Used to cancel the self diag U4 - 09/20/21/22 (large capacity tray) trouble.
Section	Paper transport
Item	Trouble
Operation/Procedure	When the [EXECUTE] key is pressed, the U6 (09/20/21/22) (LCC) trouble is canceled and the display returns to the simulation main code entry screen. After canceling this simulation, the machine resumes operation.

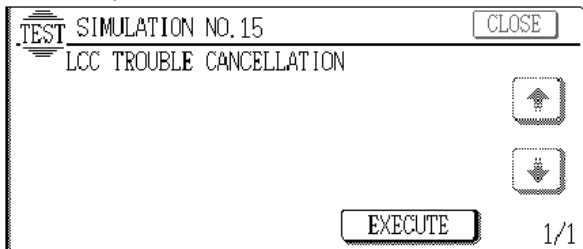

16

16 - 0

Purpose	Clear/Cancel (Trouble etc.)	
Function (Purpose)	Used to cancel the self diag U2 trouble.	
Item	Trouble	Error
Operation/Procedure	When the [EXECUTE] key is pressed, the U2 trouble is canceled and the display returns to the simulation main code entry screen. After this simulation is canceled, the machine resumes operation.	

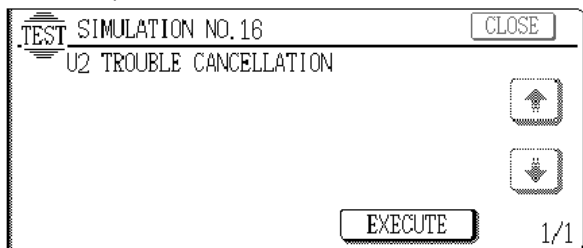

17

17 - 0

Purpose	Clear/Cancel (Trouble etc.)	
Function (Purpose)	Used to cancel copy inhibition by the host computer during the self diag PF.	
Section	Communication unit (TEL/LIU/MODEM etc.)	
Item	Trouble	Error
Operation/Procedure	When the [EXECUTE] key is pressed, the PF trouble is canceled and the display returns to the simulation main code entry screen. After this simulation is canceled, the machine resumes operation.	

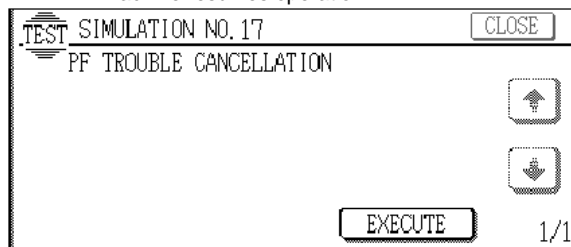

21

21 - 1

Purpose	Setting	
Function (Purpose)	Used to set the maintenance cycle.	
Item	Specifications	Counter
Operation/Procedure	When the maintenance cycle is selected with the key, the selected key is highlighted. The maintenance message is displayed in every selected cycle. When FREE is selected, the maintenance display is not shown.	

(AR-2XX/3XX series)

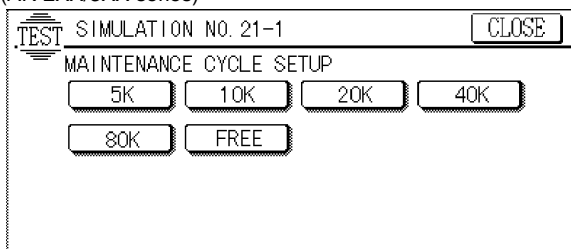

(AR-4XX series)

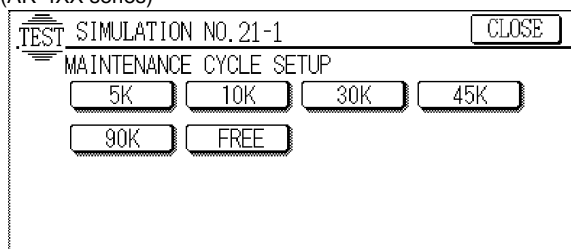

(AR-501/505)

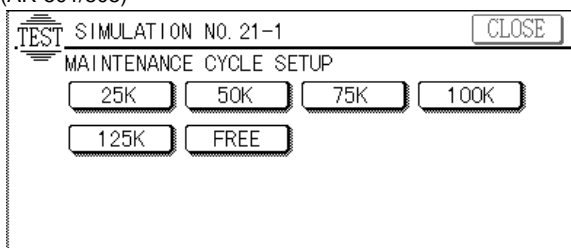

22

22 - 1

Purpose	Operation data output/Check (Display/Print)
Function (Purpose)	Used to check the print out count of each section in each operation mode. (Used to check the maintenance timing.)
Item	Counter
Operation/Procedure	FAXandPDA/ZRare only for Japan models.

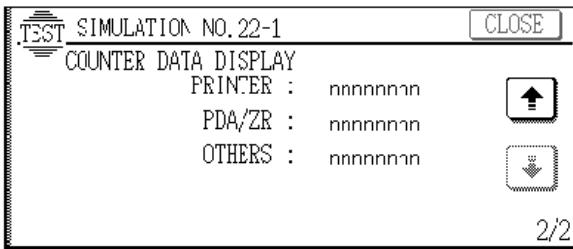
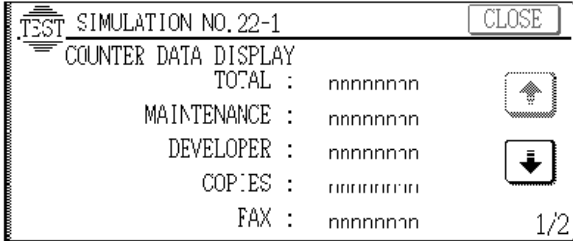

nnnnnnnn : Counter value

22 - 2

Purpose	Operation data output/Check (Display/Print)
Function (Purpose)	Used to check the total numbers of misfeed and troubles. (When the number of misfeed is considerably great, it is judged as necessary for repair. The misfeed rate is obtained by dividing this count value with the total counter value.)
Item	Mis-feed
Operation/Procedure	MACHINE JAM: The number of paper jam troubles occurred in the sections other than the document feeders (SPF/ADF/RADF). DF JAM: The number of paper jam troubles occurred in the document feeders (SPF/ADF/RADF). TROUBLE: Total number of troubles

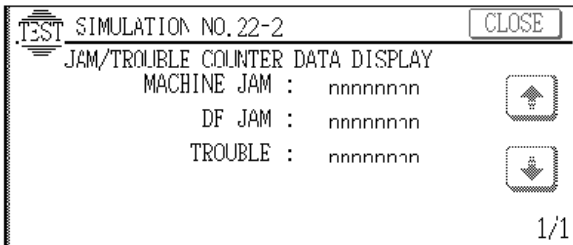

nnnnnnnn : Counter value

22 - 3

Purpose	Operation data output/Check (Display/Print)
Function (Purpose)	Used to check the misfeed positions and the number of misfeed in each position. (If the number of misfeed is considerably great, it can be judged as necessary for repair.) (Sections other than ADF/RADF/SPF sections)

Item	Mis-feed
Operation/Procedure	The misfeed history sections indicated by the sensors and detectors are displayed sequentially from the latest one. Max. 40 items of information can be stored, and the oldest one is deleted sequentially. The trouble position may be presumed with this data.

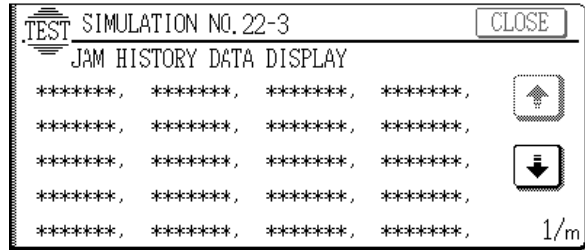

22 - 4

Purpose	Operation data output/Check (Display/Print)
Function (Purpose)	Used to check the total trouble (self diag) history.
Item	Mis-feed
Operation/Procedure	The trouble history error codes are displayed sequentially from the latest one. Max. 40 items of information can be stored, and the oldest one is deleted sequentially. The machine condition can be presumed according to this data.

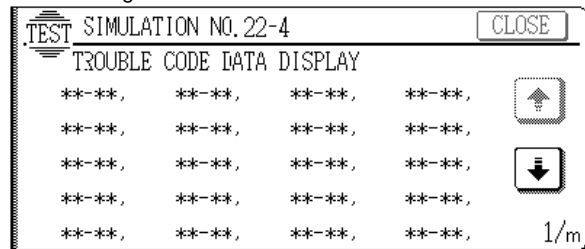

22 - 5

Purpose	Others
Function (Purpose)	Used to check the ROM version of each unit (section).
Item	Software
Operation/Procedure	The ROM version of each section can be checked. If there is any problem in the software, check the ROM version of each section with this simulation and replace with a new version if necessary. FAX is for Japan model only.

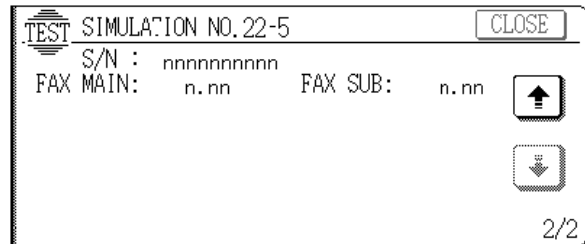
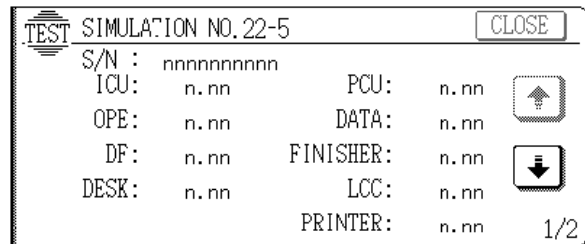

22 - 6

Purpose	Operation data output/Check (Display/Print)
Function (Purpose)	Used to output the list of the setting and adjustment data (simulations, FAX soft switch, counters).
Item	Data Adjust/Setting data
Operation/ Procedure	When installing or servicing, execute this simulation to print and store the adjustment values and setting data for use in the next servicing. (Memory trouble, PWB replacement, etc.)

In this case, the print conditions can be set optionally.

1. Select the setup item.
(The selected item is highlighted.)
2. Set the item and conditions with the 10-key pad.
3. Press the [EXECUTE] key to print various data.
 - A: Print out items (Contents)
 - 1: All adjustment values and setup data
 - 2: All counter data
 - 3: FAX soft switch setup data (Japan only)
 - 4: Print density adjustment data
 - 5: Adjustment and setup data of the other simulations
 - B: Paper feed mode
 - 1: Manual paper feed
 - 2: Upper paper feed tray
 - 3: Lower paper feed tray
 - 4: Desk upper paper feed tray
 - 5: Desk middle paper feed tray
 - 6: Desk lower paper feed tray
 - 7: Large capacity paper feed tray

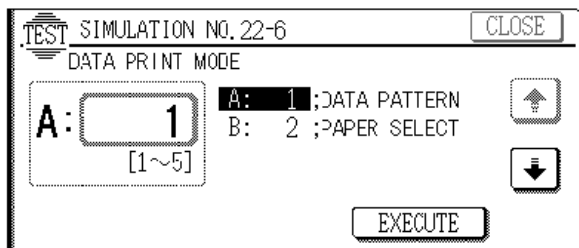

22 - 7

Purpose	User data output/Check (Display/Print)
Function (Purpose)	Used to display the key operator code. (This simulation is used when the customer forgets the key operator code.)
Item	Data User data
Operation/ Procedure	

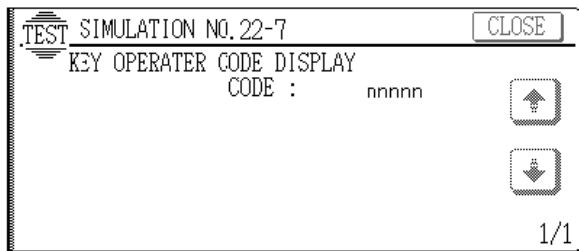

nnnnn : Key operator code

22 - 8

Purpose	Operation data output/Check (Display/Print)
Function (Purpose)	Used to check the number of use of the staple, the ADF, RADF, SPF, and scanning.
Item	Counter

Operation/ Procedure	This data is used to check the use frequency of each section. According to this data, maintenance is executed.
----------------------	--

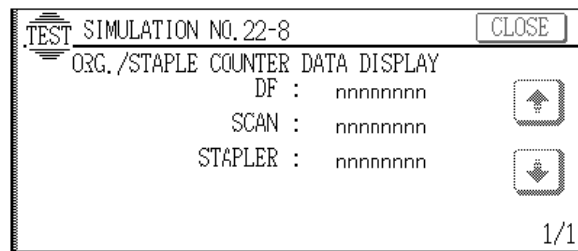

nnnnnnnn : Counter value

22 - 9

Purpose	Operation data output/Check (Display/Print)
Function (Purpose)	Used to check the number of use of each paper feed section. (the number of prints)
Section	Paper transport
Item	Counter
Operation/ Procedure	This data is used to check the use frequency of each paper feed section, According to this data, maintenance is performed.

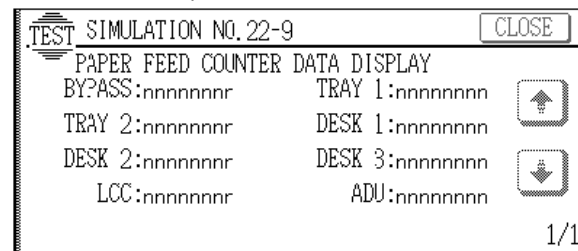

nnnnnnnn : Counter vlaue

22 - 10

Purpose	Operation data output/Check (Display/Print)
Function (Purpose)	Used to check the system configuration (option, internal hardware).
Item	Specifications Options
Operation/ Procedure	This simulation allows to check the system configuration.

The devices and the option units which are installed are displayed with the model names or size, etc.

(AR-230/280/285 series)

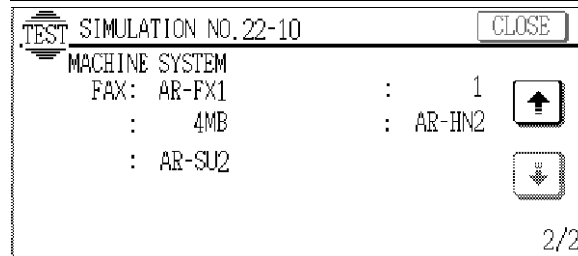
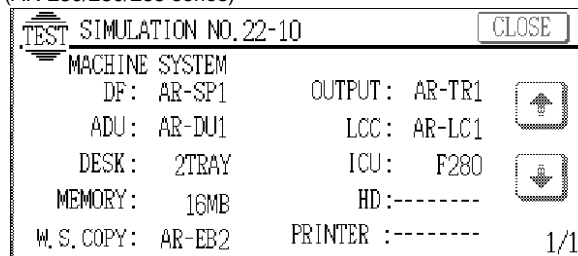

(AR-330/335 series)

TEST SIMULATION NO. 22-10		CLOSE
MACHINE SYSTEM		
DF: AR-SP1	OUTPUT: AR-TR1	↑
ADU: AR-DU1	LCC: AR-LC1	
DESK: 2TRAY	ICU: S330	↓
MEMORY: 16MB	HD: -----	
W. S. COPY: AR-EB2	PRINTER: -----	1/1

(AR-2X1/3X1/4XX/250/XX6 series)

(FAX Model)

TEST SIMULATION NO. 22-10		CLOSE
MACHINE SYSTEM		
DF: AR-SP1	OUTPUT: AR-TR1	↑
ADU: AR-DU1	LCC: AR-LC1	
DESK: 2TRAY	ICU: F281	↓
MEMORY: 48MB	HD: -----	
SCSI-A: -----	SCSI-B: -----	1/2

TEST SIMULATION NO. 22-10		CLOSE
MACHINE SYSTEM		
FAX: AR-FX1	: AR-FL1	↑
: 4MB	: AR-HN2	
: AR-SU1		↓
2/2		

(Non FAX Model)

TEST SIMULATION NO. 22-10		CLOSE
MACHINE SYSTEM		
DF: AR-DF2	OUTPUT: AR-TR1	↑
ADU: AR-DU1	LCC: AR-LC1	
DESK: 2TRAY	ICU: 405	↓
MEMORY: 16MB	HD: 2GB	
SCSI-A: AR-PB2	SCSI-B: -----	1/1

(AR-5XX series)

TEST SIMULATION NO. 22-10		CLOSE
MACHINE SYSTEM		
DF: RSPF	OUTPUT: AR-FN3	
ADU: AR-DU1	LCC: AR-LC1	
DESK: 2TRAY	ICU: 505/S505	
MEMORY: 48MB	HD: 2.1GB	
SCSI-A: -----	SCSI-B: -----	

22 - 11

Purpose	Operation data output/Check (Display/Print)
Function (Purpose)	Used to check the use frequency of FAX (send/receive). (FAX model only)
Section	FAX
Item	Data
Operation/Procedure	

22 - 12

Purpose	Operation data output/Check (Display/Print)
Function (Purpose)	Used to check the misfeed positions and the number of misfeed at each position. (When the number of misfeed is considerably great, it can be judged as necessary for repair.)
Section	SPF/ADF/RSPF/RADF
Item	Mis-feed
Operation/Procedure	

24

24 - 1

Purpose	Data clear
Function (Purpose)	Used to clear the misfeed counter, the misfeed history, the trouble counter, and the trouble history. (The counters are cleared after completion of maintenance.)
Item	Counter
Operation/Procedure	<ol style="list-style-type: none"> Select the counter to be cleared. <ul style="list-style-type: none"> MACHINE: Machine JAM counter DF: SPF/RADF/ADF JAM counter TROUBLE: Trouble counter (When selected, it is highlighted.) Press the [EXECUTE] key. The display for reconfirmation to clear is shown. Select YES or NO to clear the counter. <ul style="list-style-type: none"> YES: Clear NO: Not clear After completion of maintenance, the above counter is cleared

24 - 2

Purpose	Data clear
Function (Purpose)	Used to clear the number of use (the number of prints) of each paper feed section.
Section	Paper transport
Item	Counter
Operation/Procedure	<ol style="list-style-type: none"> Select the counter to be cleared. <ul style="list-style-type: none"> BYPASS: Manual paper feed tray counter TRAY1: Tray 1 counter TRAY2: Tray 2 counter DESK1: Desk 1 counter DESK2: Desk 2 counter

DESK3: Desk 3 counter
ADU: Duplex unit counter
LCC: Large capacity tray counter
 (When selected, it is highlighted.)

- Press the [EXECUTE] key.
The display for reconfirmation to clear is shown.
- Select YES or NO to clear the counter.
YES: Clear
NO: Not clear

After completion of maintenance, the above counter is cleared.

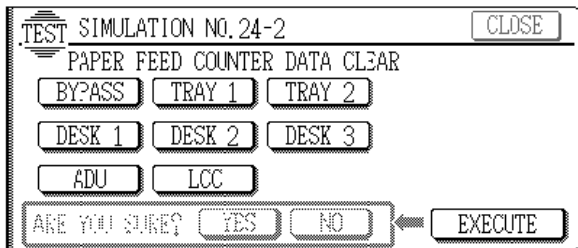

24 - 3

Purpose	Data clear
Function (Purpose)	Used to clear the data of the number of use of the staple, the SPF, ADF, RSPF, RADF and scanning.
Item	Counter
Operation/ Procedure	1. Select the counter to be cleared.

DF: ADF/SPF/RADF/RSPF counter
SCAN: Scan counter
STAPLER: Stapler counter
 (When selected, it is highlighted.)

- Press the [EXECUTE] key.
The display for reconfirmation to clear is shown.
- Select YES or NO to clear the counter.
YES: Clear
NO: Not clear

After completion of maintenance, the above counter is cleared.

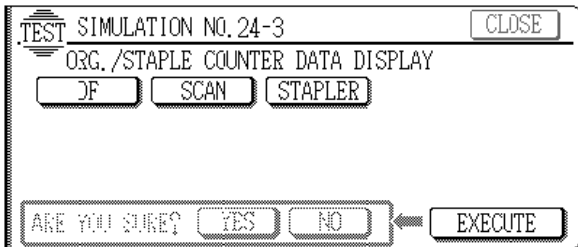

24 - 4

Purpose	Data clear
Function (Purpose)	Used to reset the maintenance counter.
Item	Counter
Operation/ Procedure	1. Press the [EXECUTE] key. The display for reconfirmation to clear is shown.

- Select YES or NO to clear the counter
YES: Clear
NO: Not clear

The above counter is cleared after completion of maintenance.

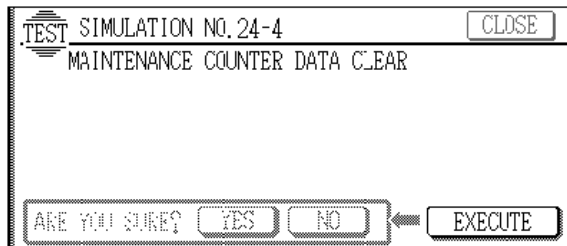

24 - 5

Purpose	Data clear
Function (Purpose)	Used to reset the developer quantity counter. (The developer counter of the installed developing unit is reset.)
Section	Image process Developer/Toner Hopper (Photoconductor/Developing/Transfer/Cleaning)
Item	Counter Developer
Operation/ Procedure	1. Press the [EXECUTE] key. The display for reconfirmation to clear is shown.

- Select YES or NO to clear the counter.
YES: Clear
NO: Not clear

The above counter is cleared after replacement of developer.

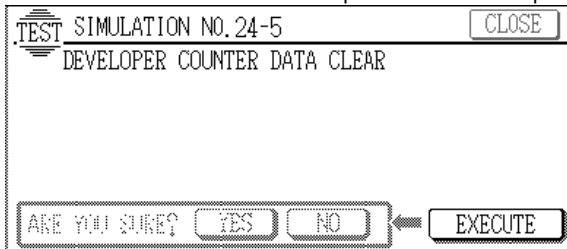

24 - 6

Purpose	Data clear
Function (Purpose)	Used to reset the copy counter.
Item	Counter Copier
Operation/ Procedure	1. Press the [EXECUTE] key. The display for reconfirmation to clear is shown.

- Select YES or NO to clear the counter.
YES: Clear
NO: Not clear

Generally, the counter is not cleared.

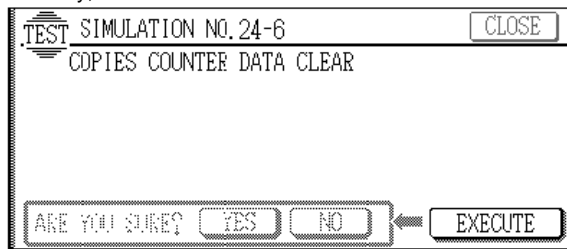

24 - 7

Purpose	Data clear
Function (Purpose)	Used to clear the OPC drum (membrane decrease) correction counter. (This simulation is executed when the OPC drum is replaced.)

Section	Image process (Photoconductor/Developing/Transfer/Cleaning)	Photo conductor
Item	Counter	Photo conductor
Operation/Procedure	1. Press the [EXECUTE] key. The display for reconfirmation to clear is shown.	

2. Select YES or NO to clear the counter.
YES: Clear
NO: Not clear

The above counter is cleared after replacement of the OPC drum.

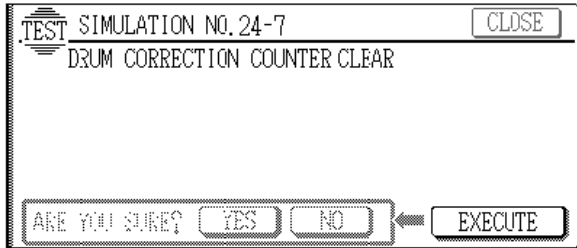

24 - 8

Purpose	Data clear
Function (Purpose)	Used to clear the Zaurus print counter.
Item	Counter
Operation/Procedure	1. Press the [EXECUTE] key. The display for reconfirmation to clear is shown.

2. Select YES (Clear) or NO (Not clear).
YES: Clear
NO: Not clear

Generally the counter is not cleared.

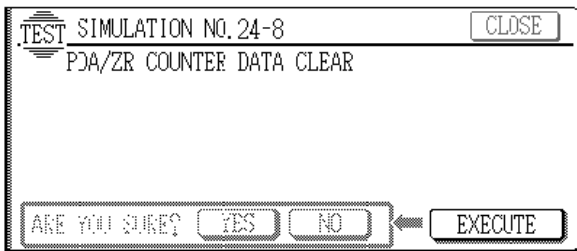

Note	Japan only
------	------------

24 - 9

Purpose	Data clear
Function (Purpose)	Used to clear the printer print counter. (The counter is cleared after completion of maintenance.)
Section	Printer
Item	Counter Printer
Operation/Procedure	1. Select the counter to be cleared. PRINTER: Printer counter OTHER: The other counters (When selected, it is highlighted.)

2. Press the [EXECUTE] key.
The display for reconfirmation to clear is shown.
3. Select YES (Clear) or NO (Not clear).
YES: Clear
NO: Not clear

The above counter is cleared after completion of maintenance.

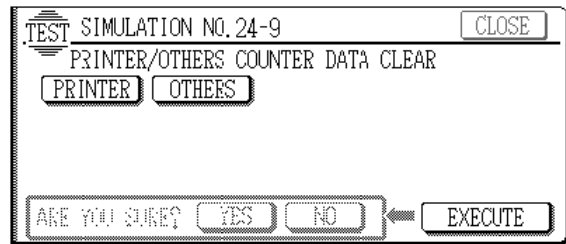

24 - 11

Purpose	Data clear
Function (Purpose)	Used to reset the developer rotation time counter. (The developer counter of the installed developing unit is reset.) (AR-501/505 only)
Section	Image process Developer/Toner Hopper (Photoconductor/Developing/Transfer/Cleaning)
Item	Counter Developer
Operation/Procedure	1. Press the [EXECUTE] key. The display for reconfirmation to clear is shown.

2. Select YES or NO to clear the counter.
YES: Clear
NO: Not clear

The counter is automatically cleared after completion of SIM 25-2.

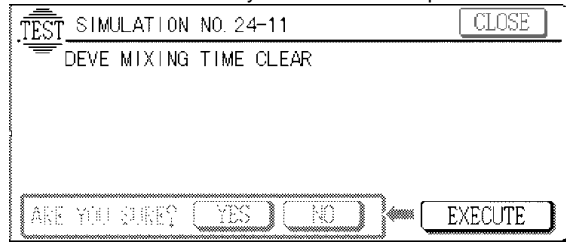

25

25 - 1

Purpose	Operation test/check
Function (Purpose)	Used to check the operation of the main drive (excluding the scanner section) and to check the operation of the toner concentration sensor. (The toner concentration sensor output can be monitored.)
Section	DRIVE
Item	Operation
Operation/Procedure	The main motor rotates for 3 minutes, and the drive system can be checked.

The toner concentration sensor output value is displayed. When the [EXECUTE] key is pressed, it is highlighted and the main motor rotates and the toner concentration sensor output value is displayed. After 3 minutes, the main motor stops and the [EXECUTE] key returns to the normal display. If the [EXECUTE] key is pressed during rotation, the operation is stopped and the [EXECUTE] key returns to the normal display.

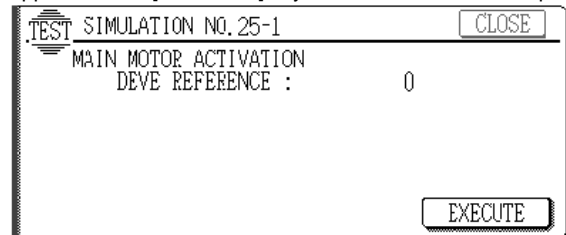

25 - 2

Purpose	Setting
Function (Purpose)	Used to make the initial setting of toner concentration when replacing developer.
Section	Image process Developer/Toner Hopper (Photoconductor/Developing/Transfer/Cleaning)

Operation/Procedure When the [EXECUTE] key is pressed, it is highlighted and the main motor rotates, and the toner concentration sensor detects the toner concentration and the output value is displayed.

After stirring for 3 minutes, the toner concentration detection level average value is set (stored) as the reference toner concentration control value.

If the [EXECUTE] key is pressed during rotation, the operation stops and the [EXECUTE] key returns to the normal display.

If [EE-EU] or [EE-EL] is displayed, it means the reference toner concentration control value is not set normally.

Default: 0

(Note) Do not set to 0.

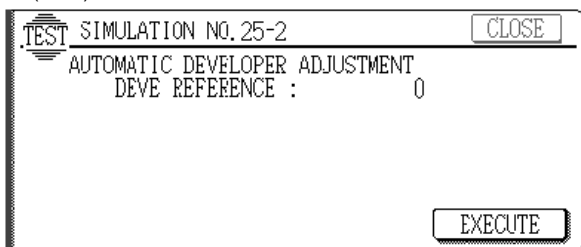

25 - 8

Function (Purpose) Used to set the timing of toner concentration control correction B and the correction quantity. The timing is determined according to the accumulated use time of developer. (AR-501/505 only)

Operation/Procedure When this simulation is executed, the current set value is displayed. Under this state, the set value can be changed by pressing the 10-key.

When [OK] key is pressed, the set value is stored in the EEPROM.

	Content	Set range	Default
A	The first correction time [min]	0 - 500	200)
B	Second and later correction time [min]	0 - 500	50
C	Number of times of correction	0 - 10	3
D	Correction quantity	0 - 30	0

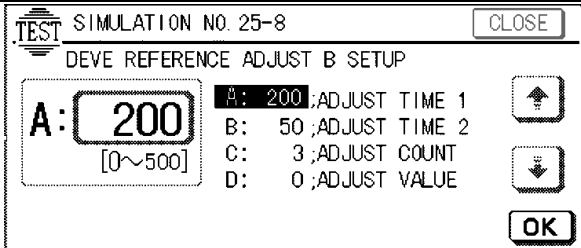

26

26 - 1

Purpose	Setting
Function (Purpose)	Used to set options. (This simulation is used to make option setting when an option is installed.)
Item	Specifications Options

Operation/Procedure Enter the code number corresponding to the option installation with the 10-key pad and press the [OK] key.

When an option is installed or removed, this setting must be changed accordingly. If this setting is improper, an error message is displayed.

(AR-230/280/285/330/335 series)

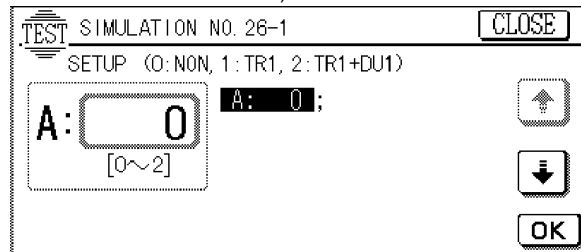

Set value	Connection option
0	No connection (Default)
1	AR-TR1
2	AR-TR1 + AR-DU1

(AR-2X1/3X1/4XX/250/XX6 series)

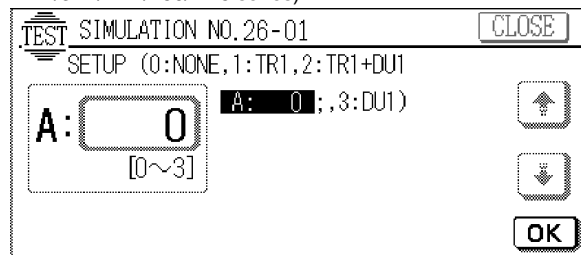

Set value	Connection option
0	No connection
1	AR-TR1
2	AR-TR1 + AR-DU1
3	AR-DU1 only

(AR-5XX series)

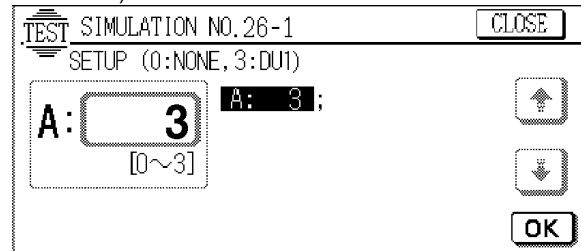

26 - 2

Purpose Setting

Function (Purpose) 1) Used to set the paper size of the large quantity paper tray. (When the paper size is changed, the lift paper size must be also changed with this simulation.)

2) Used to detect the paper or document size of 8.5" x 13" (Inch series) and set the display mode. (All paper feed modes)

Section	Paper transport
Item	Specifications

Operation/Procedure 1. Select the item to be set with [↑] key and [↓] key.

A: Large capacity paper tray paper size setting

B: 8.5" x 13" (330mm/13") paper size detection mode setting

C: Manual feed paper size setting

2. Enter the code number corresponding to the paper size of the large capacity paper feed tray with the 10-key and press the [OK] key.

Set value	Setting size
1	8.5 x 11
2	A4 (Default)
3	B5

3. Used to set the size detection mode when 8.5" x 13" paper or document is used.

Enter the code number with the 10-key pad and press the [OK] key.

* Detection size when 8.5" x 13" document/paper is used

	Unit	Destination	Set value		
			0 (Default) (Invalid)	1 (Valid)	
Document	AR-SP1	All destinations	8.5" x 14"	8.5" x 13" *1	
	AR-AF1 AR-RF1	Japan	A4R	A4R *5	
		EX AB series (SLK/SEEG)	A4R	A4R *5	
		EX AB series (SCA/ Others)	A4R	8.5" x 13" *3	
		Inch series (SEC/SECL)	8.5" x 14"	8.5" x 14" *5	
		Inch series (Others)	8.5" x 14"	8.5" x 13" *1	
Document table	Japan/EX AB series	B4	8.5" x 13" *2		
	Inch series	8.5" x 14"	8.5" x 13" *1		
Paper	Main body	Manual feed tray	All destinations	8.5" x 14"	8.5" x 13" *4
		Paper feed cassette	All destinations		— *6
	AR-DE1/DE2	All destinations			
	AR-LC1	All destinations			—

*1: A document of 8.5" x 14" is detected as 8.5" x 13".

*2: A document of B4 is detected as 8.5" x 13".

*3: A document of A4R is detected as 8.5" x 13".

*4: A document of 8.5" x 14" is detected as 8.5" x 13".

*5: Applicable by replacing the document set tray of the AR-AF1/RF1.

*6: Setting is available with the key operator program (P40).

Value	Display	Paper	
1	Characters	HEAVY PAPER	PLAIN PAPER
2	Weight in g.	106 - 200 g/m ²	56 - 105 g/m ²
3	Weight in lbs.	28+ - 55 lbs	15 - 28 lbs

26 - 3

Purpose	Setting
Function (Purpose)	Used to set the specifications of the auditor. Setting must be made depending on the use condition of the auditor.
Section	Auditor
Item	Specifications
Operation/ Procedure	Enter the code number corresponding to the auditor specification mode with the 10-key pad and press the [OK] key.

Set value	Specification mode
1	Built-in auditor mode (Default)
2	Coin vendor
3	Others

26 - 5

Purpose	Setting
Function (Purpose)	Used to set the count mode of the total counter and the maintenance counter.
Item	Specifications Counter
Operation/ Procedure	Used to set the single count-up or double count-up for the total counter, the maintenance counter, and the developer counter when printing is performed with A3, 11 x 17" paper,

- Select the kind of the counter with [↑] and [↓] key.

A	Total
B	Maintenance
C	Developer

- Enter "1" or "2" with the 10-key pad and press the [OK] key.

- Single count
- Double count

Default: 2

26 - 6

Purpose	Setting
Function (Purpose)	Used to set the specifications depending on the destination.
Item	Specifications the Destination destination
Operation/ Procedure	Select the destination referring to the table below.

U.S.A.	United States of America
Canada	Canada
Inch	Inch series, other destinations
Japan	Japan
AB_B	AB series (B5 detection) other destinations
Europe	Europe
U.K.	United Kingdom
Aus.	Australia
AB_A	AB series (A5 detection) other destinations

When the destination setting is changed, the following specification is changed.

(Toner save mode setup specification) (Paper specification)

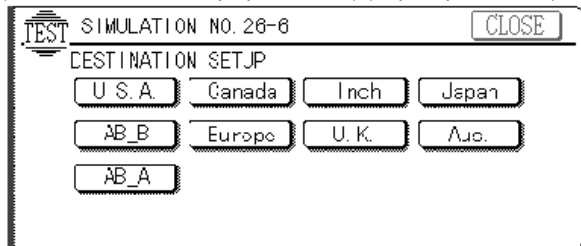

26 - 15

Purpose	Setting
Function (Purpose)	Used to set the fusing operation mode (paper curl corresponding mode).
Section	Fixing (Fusing)
Item	Operation
Operation/ Procedure	Due to the paper type (paper property), paper may be curled in the fusing section and cause a paper jam. To prevent against this, the fusing condition is changed.

Enter the code number corresponding to the fusing condition and press the [OK] key.

Set value	Remedy mode	Fusing condition
0	Normal operation	(Default)
1	Remedy mode 1	a. Racing until the specified fusing temperature is reached.
2	Remedy mode 1	a. Racing is performed until the specified fusing temperature is reached. b. Copy mode is duplex mode or sort. Group mode • Previous rotation is made for 5 sec before starting copying.

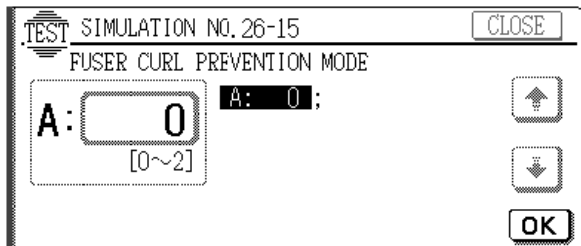

26 - 18

Purpose	Setting
Function (Purpose)	Used to set VALID/INVALID of toner save operation. (This simulation is valid only in the Japan and UK versions. (It depends on SIM 26-6 (Destination setting). For the other destinations, the same setting can be executed with the user program.)

Item	Specifications	Operation mode (Common)
Operation/ Procedure	Enter the code number corresponding to the condition (the toner save YES/NO) with the 10-key and press the [OK] key.	

Set value	Toner save
0	YES
1	NO (Default)

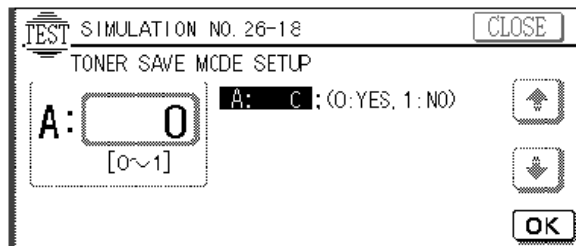

26 - 22

Purpose	Setting
Function (Purpose)	Used to set the specification (language display) for the destination. (Target models: AR-280/285/335) (Excluding the Japan models.)
Item	Specifications
Operation/ Procedure	Select the language to be used according to the table below.

Display	Language
ENG.(US)	English(US)
ENG.(UK)	English(UK)
FRENCH	French
SPANISH	Spanish
GERMAN	German

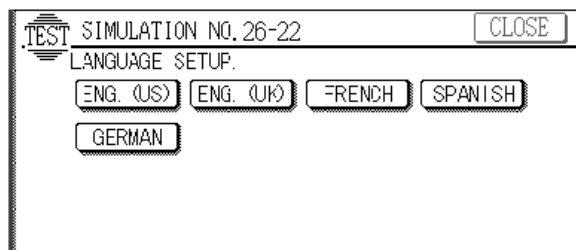

26 - 30

Purpose	Setting	
Function (Purpose)	Used to set the CE mark conforming operation mode. (For flickers when driving the fusing heater lamp.)	
Item	Specifications	Operation mode (Common)
Operation/ Procedure	Enter the number corresponding to the operation mode with the 10-key and press the [OK] key.	

Set value	Content
0	CE mark control inhibit
1	CE mark control allowed (Default)

- 0: Normal operation heater lamp slow up control
- 1: CE mark standard complying operation (Heater lamp slow up control) (Europe)

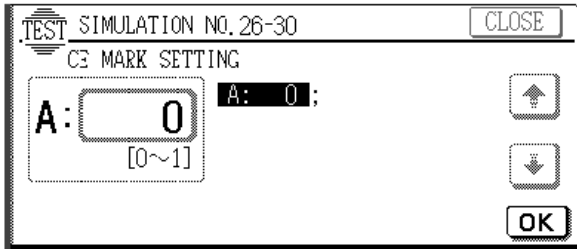

26 - 35

Purpose	Setting
Function (Purpose)	Used to set whether the trouble history display of SIM 22-4 is displayed as one trouble or as the number of continuous troubles when two or more troubles of a same kind occurred.
Item	Specifications
Operation/ Procedure	Used to set whether the trouble history display by SIM 22-4 is displayed as one trouble or as the accumulated number of continuous troubles when two or more troubles of same kind occur continuously.

Select the number corresponding to the display mode with the 10-key and press the [OK] key.

- 1: The trouble history display by SIM 22-4 is displayed as it is when two or more troubles occur continuously.
- 0: The trouble history display by SIM 22-4 is displayed as one trouble when two or more troubles occur continuously.

Default: 0

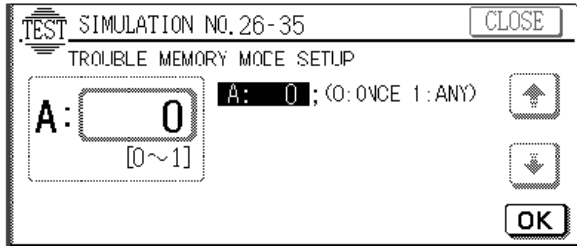

26 - 36

Purpose	Setting
Function (Purpose)	Used to set the ICU fan operating temperature. (Operation in pre-heat mode.) (Excluding Japan models.)
Section	ICU
Item	Operation
Operation/ Procedure	Used to set the threshold value of the ambient temperature for turning ON the ICU fan motor in the pre-heat mode. Set range : 0~33[°C] Default : 30[°C] (30) Enter the operating temperature with the 10-key pad and press the [OK] key.

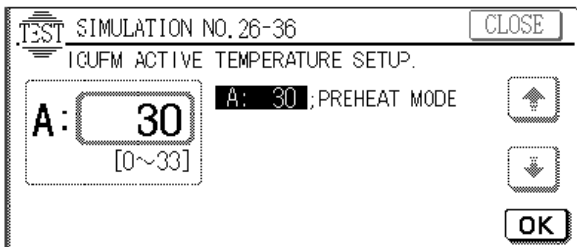

26 - 40

Purpose	Setting
Function (Purpose)	Polygon motor stop mode setup (AR-501/505) Used to set the stop time of the polygon motor after leaving in ready state and to set Enable/Disable of the setting. (Other models)
Item	Specifications
Operation/ Procedure	(AR-501/505) When this simulation is executed, the current set value is displayed.

At that time, the set value can be changed with the 10-key. When the OK key is pressed, the currently set value is stored in the EEPROM.

Default: 0

0	Normal mode	Control according to the setup in the silent mode by the user setup.
1	Silent mode	After completion of a job, the polygon motor is stopped in the time set in the silent mode of the user setup.

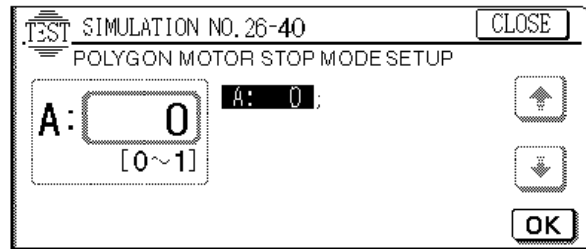

(Other models)

A

- Used to set the time (minute) to stop the polygon motor with the 10-key.
(Regardless of setting in B, the time can be freely set.)
- Press the OK key to store the set time.
- Press the CA key to reset. Only when B is set to "1: YES", the polygon motor is stopped in the set time.
Set range: 1-30 min
Default: 30 min

B Used to set YES/NO of the setup of A.
Default: 0 (NO)

Set value	Content
0	NO (The currently set operation is performed.) → SP/FP does not stop. 40 NEW Stops in the default time (30 min).
1	Stops in the set value of A.

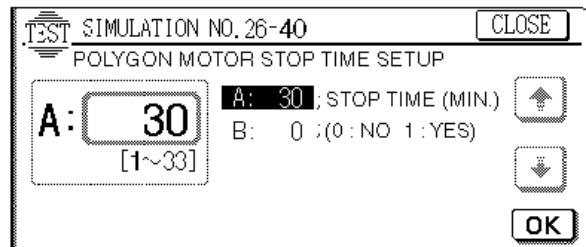

26 - 41

Purpose	Setting	
Function (Purpose)	Used to enable/disable the auto magnification ratio select (AMS) function in the pamphlet copy mode.	
Item	Specifications	Operation mode (Common)

Operation/ Procedure This simulation is used to enable or disable the automatic magnification ratio selection (AMS) in the pamphlet mode.

Set value	Set content
0	Automatic magnification ratio selection (AMS) is enabled.
1	Automatic magnification ratio selection (AMS) is disabled.

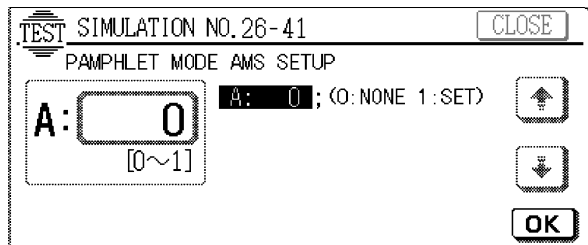

26 - 44

Purpose Setting
Function (Purpose) Used to set the model of the unit which is connected to the SCSI I/F of ICU PWB.
Section ICU
Item Specifications Interface/Communication

Operation/ Procedure A is at the left of B when viewed from the rear side.
 0: No connection
 1: Printer controller
 3: External printer controller (Not used)
 4: Scanner controller (Not used)
 8: Tandem connection (Initiator)
 10: Tandem connection (Target)

One SCSI channel available (Japan only)

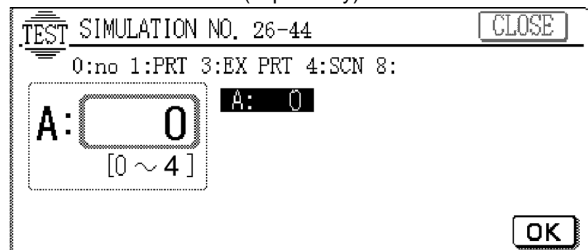

Two SCSI channels available (AR-501/505)

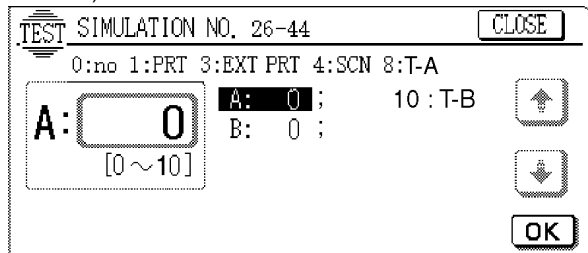

(Other models)

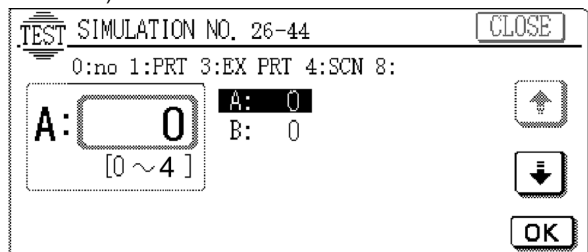

26 - 46

Purpose Setting
Function (Purpose) Used to set the image direction or not regardless of modes when the finisher/sorter is installed.
Item Specifications Operation mode (Common)

Operation/ Procedure This simulation is used to set the image direction or not regardless of modes when the finisher/sorter is installed. (Other models than AR-501/505)

Set value	Set content
0	Not set. (The image direction is changed in the staple mode of FN1*.)
1	Set. (The image direction is not changed regardless of presence of the staple.)

Default: 0

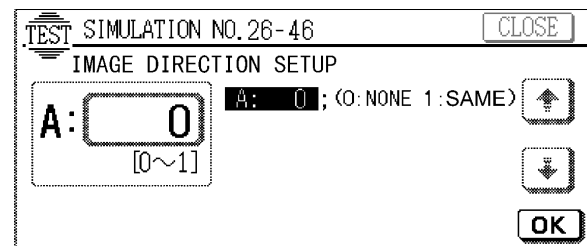

26 - 50

Purpose Setting
Function (Purpose) Used to set YES/NO of black/white reversion is allowed.
Item Specifications

Operation/ Procedure When this simulation is executed, the current set value is displayed. At that time, the set value can be changed with the 10-key.

When the OK key is pressed, the currently set value is stored in the EEPROM.

Default: 1 (YES) (Black/white reversion is allowed.)

0	NO: Black/white reversion is inhibited.
1	YES: Black/white reversion is allowed.

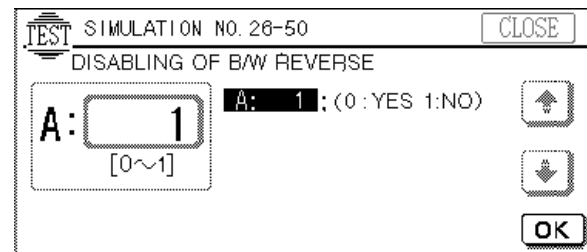

27

27 - 1

Purpose Setting
Function (Purpose) Used to set the operation specifications when a communication trouble occurs between the host computer and MODEM (on the copier). (When a communication trouble occurs between the host computer and MODEM (copier), the self diag display (U7-00) is printed and setting is made to select inhibit/allow of printing.)

Section Communication unit (TEL/LIU/MODEM etc.)

Item	Specifications	Operation mode (Common)
Operation/Procedure	Enter the code number corresponding to the operation mode with the 10-key and press the [OK] key. Used to set Enable/Disable of U7-00 trouble detection.	

Set value	Content
0	U7-00 trouble detection is disabled. (Default)
1	U7-00 trouble detection is enabled.

- 0: Though a communication trouble occurs between the host computer and the MODEM (machine side), the operation of the machine is not affected.
- 1: When a communication trouble occurs between the host computer and the MODEM (copier side), the self diag display (U7-00) is shown and printing is inhibited.

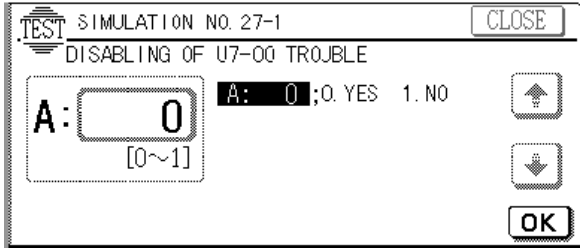

27 - 2

Purpose	Setting
Function (Purpose)	Used to set and change the host computer/MODEM numbers. (This setting is required when a communication is made between the copier and a computer through MODEM.)
Section	Communication unit (TEL/LIU/MODEM etc.)
Item	Data User data
Operation/Procedure	1. Select the PC/MODEM(HOST#/TEL#) to be set or changed. The selected key is highlighted.

- 2. Press the [OK] key.
The key is highlighted and inquiring of the present set number of the selected PC/MODEM is made to the host computer.
(When the number is supplied from the host normally.)
The present set number is displayed in the column of PRESENT (or no display is made if not registered) and the [OK] key at the upper right returns from the gray display to the normal display.
(In case of a trouble)
"Failed (U7-00)" is displayed in the column of PRESENT and the OK key at the lower right returns from the highlight display to the normal display.
- 3. When changing the number, enter the new number (max. 24 digits) with the 10-key and the following keys.
#: [P]((program) key
*: [AUDIT CLEAR] ((Dept. count end) key
, : [i]((Information) key
- 4. When the [OK] key at the upper right is pressed, the newly set number for the selected PC/MODEM is registered.
(When registered normally)
The number displayed in the column of NEW disappears and the newly set number appears in the column of PRESENT
(In case of a trouble)
"Failed (U7-00)" is displayed in the column of NEW.

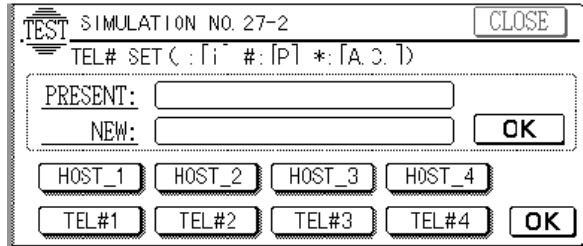

Note For this setting, the copier and the host computer must be connected with a communication line (MODEM).

27 - 3

Purpose	Setting
Function (Purpose)	Used to set and change the ID numbers of the copier and the host computer/MODEM numbers. (This setting is required when a communication is made between the copier and a computer through MODEM.)
Section	Communication unit (TEL/LIU/MODEM etc.)
Item	Data User data
Operation/Procedure	1. Select between PPC(copier) and PC/MODEM(host). The key is highlighted.

- 2. Press the [OK] key at the lower right. (The key is highlighted and an inquiry of the selected ID No. to the host.)
(When the number is supplied from the host normally)
The present set number is displayed in the column of PRESENT (or no display is made if not registered) and the [OK] key at the upper right returns from the gray display to the normal display.
(In case of a trouble)
"Failed (U7-00)" is displayed in the column of PRESENT and the OK key at the lower right returns from the highlight display to the normal display.
- 3. When changing the number, enter the new number (max. 24 digits) with the 10-key and the following keys.
X: [P](program) key
Y: [AUDIT CLEAR](dept. count end) key
The entered number is displayed in the column of "NEW"
- 4. When the [OK] key at the upper right is pressed, the newly set ID number of the selected PC/MODEM is registered on the host side.
(When registered normally)
The number in the column of NEW disappears and the newly set and registered number appears in the column of PRESENT.
(In case of a trouble)
"Failed (U7-00)" is displayed in the column of NEW

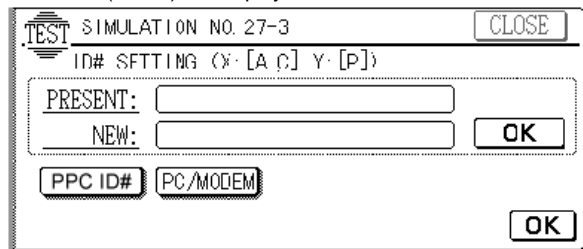

Note For this setting, the copier and the host computer must be connected with a communication line (MODEM).

27 - 4

Purpose	Setting
Function (Purpose)	Used to enter the start time and the end time of servicing for management of service work. (The data can be checked by the host computer.)

Section	Communication unit (TEL/LIU/MODEM etc.)
Item	Data
Operation/ Procedure	<ol style="list-style-type: none"> 1. Press the [SERVICE START]key when starting servicing. The key is highlighted. 2. Press the [EXECUTE]key. The key is highlighted and the data on service start time is sent. 3. Press the [SERVICE END]Key after completion of servicing. The key is highlighted. 4. Press the [EXECUTE]key . The key is highlighted and the data on service end time is sent. When the host receives the data normally, "Complete" is highlighted. In case of a trouble, "Failed" is highlighted.

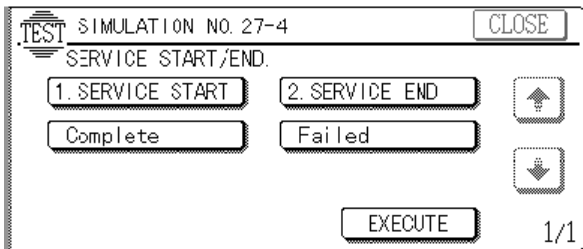

Note For this setting, the copier and the host computer must be connected with a communication line (MODEM).

27 - 5

Purpose	Setting
Function (Purpose)	Used to enter the TAG No. of the copier. (This simulation allows to check the machine TAG No. with the host computer.)
Section	Communication unit (TEL/LIU/MODEM etc.)
Item	Data
Operation/ Procedure	<ol style="list-style-type: none"> 1. When entering the tag No. newly or changing the tag No. enter the value (max. 8 digits) with the 10-key. The entered number is displayed in the column of "NEW" 2. Press the [OK] key. The new tag No. entered in procedure 1 is set. It is advisable to enter the machine's SER No. for machine management and servicing.

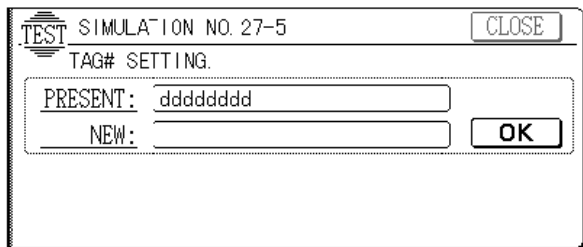

Note For this setting, the copier and the host computer must be connected with a communication line (MODEM).

30

30 - 1

Purpose	Operation test/check
Function (Purpose)	Used to check the operation of sensors and detectors in the paper feed section, the paper transport section, and the paper exit section, and the related circuit.
Section	Others

Item	Operation
Operation/ Procedure	The operations of the sensors and detectors in the sections other than the paper feed section of the copier are displayed. The active sensors and detectors are highlighted.

DSWF	Copier front door open/close
DSWL	Copier left door
DSWLL	Copier left lower door
DSWR	Copier right door
DVCH1	Developing unit installation detection
DVCH2	Developing unit installation detection
DVCH3	Developing unit installation detection
DVCH4	Developing unit installation detection
PFD	Paper vertical transport sensor
PPD1	Paper transport sensor 1
PPD2	Paper transport sensor 2
PSD	Paper transport sensor
POD1	Paper exit sensor 1
POD2	Paper exit sensor 2
POD3	Paper exit sensor 3
TFD	Waste toner bottle full detection
TMS	Toner motor missing detection

(AR-501/505)

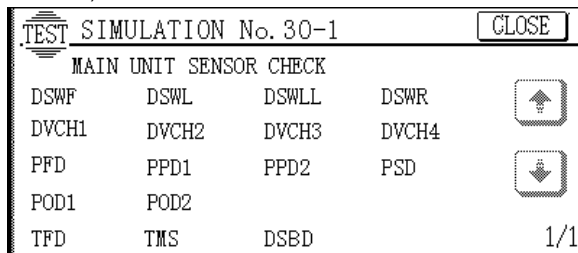

(Other models)

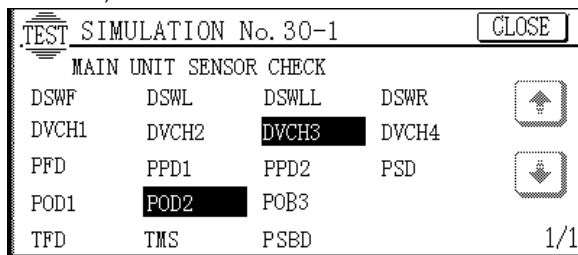

30 - 2

Purpose	Operation test/check
Function (Purpose)	Used to check the operation of sensors and detectors in the paper feed section and the related circuits. (The operations of sensors and detectors in the paper feed section can be monitored with the LCD.)

Section	Paper transport
Item	Operation
Operation/ Procedure	The operations of the sensors and detectors in the paper feed section of the copier are displayed. The active sensors and detectors are highlighted.

UCSS1	Copier upper tray paper size detection 1
UCSS2	Copier upper tray paper size detection 2
UCSS3	Copier upper tray paper size detection 3
UCSS4	Copier upper tray paper size detection 4
LUD1	Copier upper tray upper limit detection
PED1	Copier upper tray paper detection
UCSPD1	Copier upper tray paper size detection
LCSS1	Copier lower tray paper size detection 1
LCSS2	Copier lower tray paper size detection 2

	LCSS3	Copier lower tray paper size detection 3
	LCSS4	Copier lower tray paper size detection 4
	LUD2	Copier lower tray paper detection
	PED2	Copier lower tray paper detection
	LCSPD1	Copier lower tray paper size detection
	MPLS1	Manual tray length detection 1
	MPLS2	Manual tray length detection 2
	MPLD1	Manual feed paper length detection 1
	MPLD2	Manual feed paper length detection 2
	MPED	Manual tray paper empty detection
One of these is displayed	A4/A3	Manual tray (width only) detection size
	11x	Manual tray (width only) detection size
	B5/B4	Manual tray (width only) detection size
	8.5x	Manual tray (width only) detection size
	A5/A4R	Manual tray (width only) detection size
	B5R	Manual tray (width only) detection size
	POSTCARD	Manual tray (width only) detection size
	EXTRA	Manual tray (width only) detection size

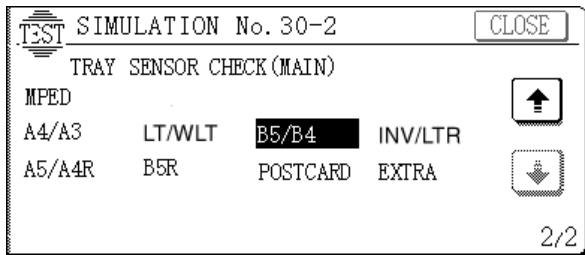
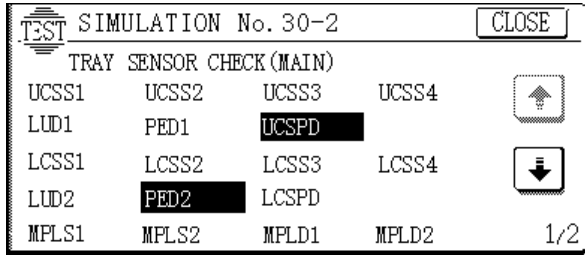

40

40 - 1

Purpose	Operation test/check
Function (Purpose)	Used to check the operation of the manual paper feed tray paper size detector and the related circuit. (The operation of the manual paper feed tray paper size detector can be monitored with the LCD.)
Section	Paper transport
Item	Operation
Operation/Procedure	The operations of the sensors and detectors in the manual paper feed section are displayed. The active sensors and detectors are highlighted.

One of these is displayed.	MPLS1	Manual tray length detection 1
	MPLS2	Manual tray length detection 2
	MPLD1	Manual feed paper length detection 1
	MPLD2	Manual feed paper length detection 2
	A4/A3	Manual tray (width only) detection size
	11x	Manual tray (width only) detection size
	B5/B4	Manual tray (width only) detection size
	8.5x	Manual tray (width only) detection size
	A5/A4R	Manual tray (width only) detection size
	B5R	Manual tray (width only) detection size
POSTCARD	Manual tray (width only) detection size	
EXTRA	Manual tray (width only) detection size	

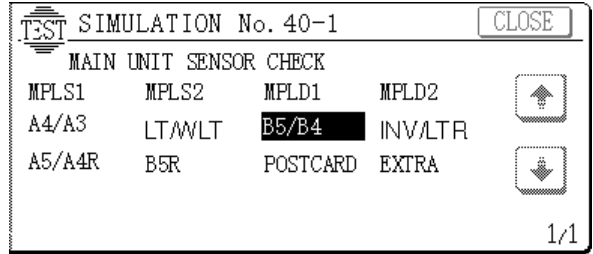

40 - 2

Purpose	Adjustment
Function (Purpose)	Used to adjust the manual paper feed tray paper width detector detection level.
Section	Paper transport
Item	Operation
Operation/Procedure	1. Open the manual paper feed guide at maximum. 2. Press the [MAX POSITION] key.

- Press the [EXECUTE] key. The [EXECUTE] key is highlighted then it returns to the normal display. The manual paper feed guide max. width position detection level is recognized.
- Open the manual paper feed guide at minimum.
- Press the [MIN POSITION] key.
- Press the [EXECUTE] key. The key is highlighted then it returns to the normal display. The manual paper feed guide min. position detection level is recognized.

If the above operation is not performed properly, the ERROR display is highlighted. If performed properly, the above data is stored and the COMPLETE is highlighted.

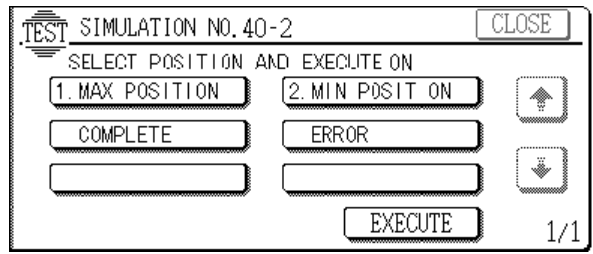

41

41 - 1

Purpose	Operation test/check/Operation data output/Check (Display/Print)
Function (Purpose)	Used to check the operation of the document size sensor and the related circuit. (The operation of the document size sensor can be monitored with the LCD.)
Section	Others
Item	Operation
Operation/Procedure	The operations of the sensors and detectors in the document size detection section are displayed. The active sensors and detectors are highlighted.

OCSW	Document cover state	Normal display: Open	Highlighted display: Close
PD*	Document sensor	Normal display: Document empty	Highlighted display: Document exist

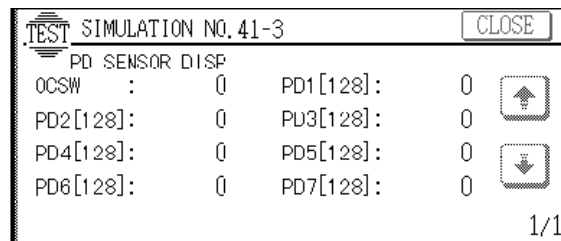
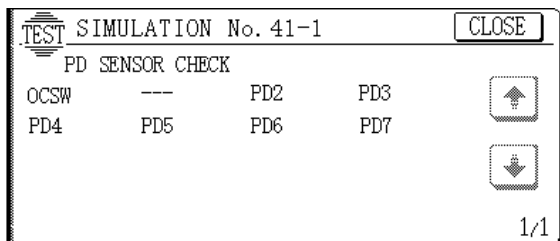
**41 - 2**

Purpose	Adjustment
Function (Purpose)	Used to adjust the document size sensor detection level.
Section	Others
Item	Operation
Operation/ Procedure	1. Open the original table, and press the [EXECUTE] key with no original on the original table. The sensor level setting with no original on the table is performed.

(Normal case) The COMPLETE display is highlighted (for 1 sec), then it returns to the normal display.

(Abnormal case) The INCOMPLETE display and the abnormal sensor name are highlighted.

- Set an A3 paper (11" x 17") and press the [EXECUTE] key. The sensor level setting with original is performed.

(Normal case) The COMPLETE display is highlighted (for 1 sec), then it returns to the normal display. The "NO ORIGINAL" display turns to "A3 ORIGINAL".

(Abnormal case) The INCOMPLETE display and the abnormal sensor names are highlighted.

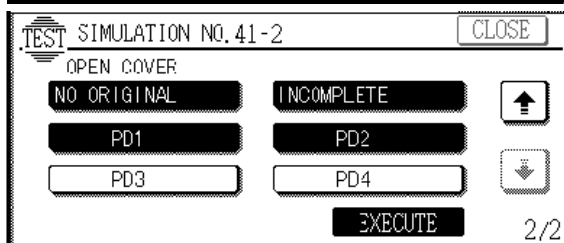
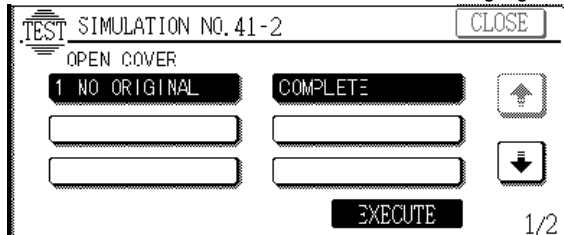
**41 - 3**

Purpose	Operation test/check
Function (Purpose)	Used to check the operation of the document size sensor and the related circuit. (The document size sensor output level can be monitored with the LCD.)
Section	Others
Item	Operation
Operation/ Procedure	The detection output level of each sensor is displayed in real time.

OCSW	Document cover state
PD*	Document sensor

* The value in [] shown at the right of each sensor name is the threshold value.

43**43 - 1**

Purpose	Setting
Function (Purpose)	Used to set the fusing temperature in each operation mode.
Section	Fixing (Fusing)
Item	Operation
Operation/ Procedure	1. Select the kind of lamps and the operation mode with [↑], [↓] keys.

- Enter the set value with the 10-key.

- Press the [OK] key to set the fusing temperature set in procedure 2.

Used to set the fusing temperature in the normal mode and in the power save mode.

INSIDE NORMAL: The control temperature in the normal mode and when the center lamp is heated. (190) (AR-501/505 (200))

OUTSIDE NORMAL: The control temperature in the power save mode (pre-heat mode) and the side lamps are heated. (190) (AR-501/505 (200))

INSIDE PREHEAT: The control temperature in the manual copy mode when the center lamp is heated. (*1)

OUTSIDE PREHEAT: The control temperature in the manual copy mode when the side lamps are heated. (*2)

INSIDE MFT: The control temperature in the manual copy mode when the center lamp is heated. (200)

OUTSIDE MFT: The control temperature in the manual copy mode when the side lamps are heated. (200)

(): Default

Destination	Pre-heat mode fusing temperature set value		
	MODEL		
	AR-230/280/285 series AR-2X1/2X6/3X1/250 series	AR-330/335 series AR-3X6 series	AR-4XX series AR-501/505
U.S.A. (Inch)	125	130	140
Canada (Inch)	125	130	140
Other (Inch)	125	130	140
Japan	130	130	140
Other (AB)	125	130	140
Europe (AB)	110	130	140
U.K. (AB)	110	130	140
Aus. (AB)	110	130	140

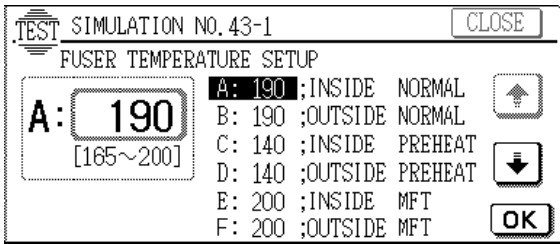

Note Be sure to set to the default value. If not, a trouble may occur.

43 - 3

Function (Purpose) Used to adjust the fusing motor speed. (AR-501/505 only)

Operation/ Procedure When this simulation is executed, the current set value is displayed. Under this state, the set value can be changed by pressing the 10-key. When [OK] key is pressed, the set value is stored in the EEPROM.

Adjustment value	70	100	130
Speed	97%	100%	103%

An increase in the adjustment value by 1 corresponds to an increase in the speed by 0.1%
 A decrease in the adjustment value by 1 corresponds to a decrease in the speed by 0.1%

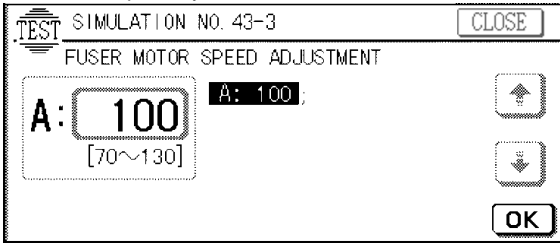

43 - 8

Function (Purpose) Used to set the time to rotate the fusing motor after reaching the set temperature in warming up. (AR-501/505 only)

Operation/ Procedure When this simulation is executed, the current set value is displayed. Under this state, the set value can be changed by pressing the 10-key. When [OK] key is pressed, the set value is stored in the EEPROM.

Set range: 10 – 120 sec
 Default: Varies according to the destination setup (SIM 26-6).
 Japan: 30 sec
 EX Japan: Varies according to the destination.

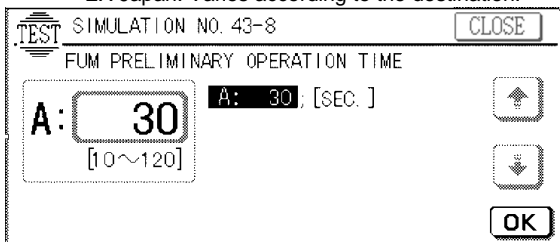

44

44 - 1

Purpose Setting

Function (Purpose) Used to set whether the correction functions of the image forming (process) section are valid or not.

Section	Image process (Photoconductor/Developing/Transfer/Cleaning)
Item	Operation
Operation/ Procedure	Enter the code number corresponding to each correction operation with the 10-key and press the OK key.

To enable all the correction functions, set to 3.
 (Note) The default setting must be 3.

Set value	Developing bias voltage correction limit	OPC drum sensitivity correction
0	Disable	Disable
1	Disable	Enable
2	Enable	Disable
3	Enable	Enable

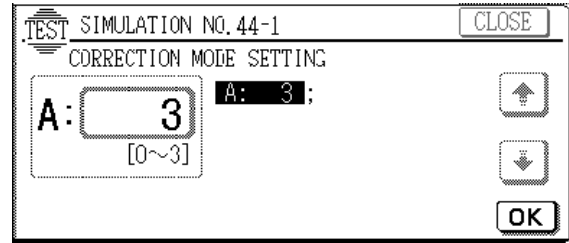

Note (Note) It must be set to the default 3.

44 - 2

Purpose Adjustment

Function (Purpose) Used to adjust the sensitivity (gain) of the OPC drum mark sensor and the image density sensor.

Section Image process Photo conductor
 (Photoconductor/Developing/Transfer/Cleaning)

Item Operation

Operation/ Procedure When the [EXECUTE] key is pressed, it is highlighted and the main motor rotates to start the drum marking sensor and the image density sensor gain adjustment. (The adjustment is automatically performed.)

After completion of the adjustment, the [EXECUTE] key returns to the normal display and the main motor stops.
 At that time, the gain level of each sensor is displayed.
 If the adjustment is not completed properly, the ERROR display is shown.

- DMLED:** Drum marking sensor gain adjustment value
 - PCLED:** Image density sensor gain adjustment value
 - DRUM:** Kinds of drums
- 0: Others
 1: AR330DR/AR336DR/AR336DM/ARdR23; 10mm
 2: AR330DM/ARdR17; 3 x 4 x 3mm
 3: AR400DR/AR400DM; 15mm
 5: AR500DR/AR500DM/ARdR25; 5mm
 As other models except AR-501/505 do not recognize 5mm marking, "0" is displayed at that time.

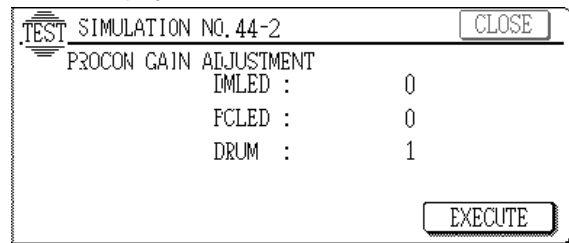

44 - 4

Purpose	Setting
Function (Purpose)	Used to set the target image (reference) density level in the developing bias voltage correction.
Section	Image process (Photoconductor/Developing/Transfer/Cleaning)

Item	Data	Adjust/Setting data
Operation/ Procedure	1. Enter the set value (38) with the 10-key. 2. Press the [OK] key. (The value entered in procedure 1 is set.)	

Set value: 36 (AR-501/505), 38 (Other models)

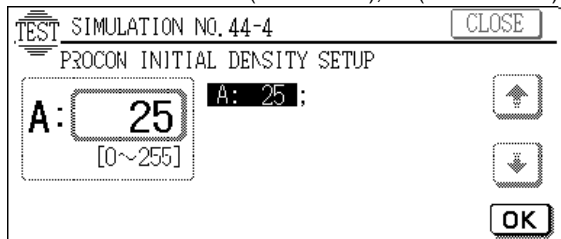

Note	It must be set to 36 for AR-501/505 or 38 for other models.
------	---

44 - 5

Purpose	Setting
Function (Purpose)	Used to set various parameters (main charger grid voltage, laser beam power, correction start developing bias voltage) in developing bias correction.
Section	Image process (Photoconductor/Developing/Transfer/Cleaning)

Item	Operation
Operation/ Procedure	1. Select the parameter mode with [↑], [↓] keys. 2. Enter the parameter with the 10-key.

3. Press the [OK] key. (The value entered in procedure 2 is set.)

GRID BIAS VOL: Reference charging voltage level in patch forming (AR-501/505; 360), other models; 380) (Set value)

DEVE BIAS VOL : Reference developing bias voltage level in patch forming (210) (Set value)

LASER DUTY: Laser duty level in patch forming (255)

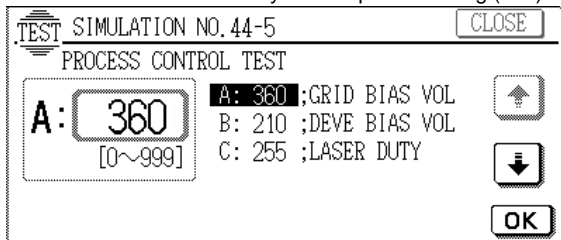

Note	Be sure to set to the specified value. If not, the print image density may be disturbed.
------	--

44 - 9

Purpose	Operation data output/Check (Display/Print)
Function (Purpose)	Used to check the data on the result of the image forming section correction (process correction) (the corrected main charger grid voltage in each print mode, developing bias voltage, the laser power, etc.) (This simulation allows to check whether the correction is executed properly or not.)

Section	Image process (Photoconductor/Developing/Transfer/Cleaning)
---------	---

Item	Data	Operation data (Machine condition)
Operation/ Procedure	Used to display the drum rotating time and the high voltage output in each copy mode and the laser power correction power.	

(AR-250/280/281/285/286/335/336/405)

DRUM ROTATION: Drum rotating time (sec)
DEVE REFERENCE ADJUST: Toner concentration correction amount

DRUM: Drum identification result
 0: Others
 1: AR330DR/AR336DR/AR336DM/ARdR23; 10mm
 2: AR330DM/ARDR17; 3 x 4 x 3mm
 3: AR400DR/AR400DM; 15mm
 5: AR500DR/AR500DM/ARDR25; 5mm
 As other models except AR-501/505 do not recognize 5mm marking, "0" is displayed at that time.

GR_BS: Main charger grid voltage level (*1)
DV_BS: Developing bias voltage level (*1)
 (Display) *1 : Sim 8-1, 8-2 Set voltage/actual output voltage (including corrected amount)

LD_AD: Laser power correction power display (mW)

AUTO: Auto mode

CHARA: Character mode

CHARA_P: Character/photo mode

PHOTO: Photo mode

PRT: Printer mode

FAX: Fax mode (Japan only)

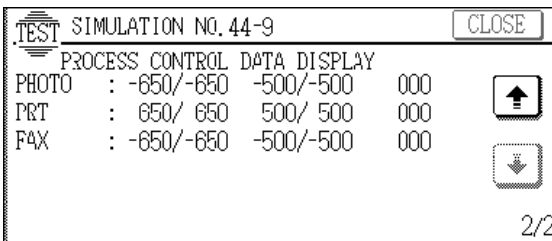
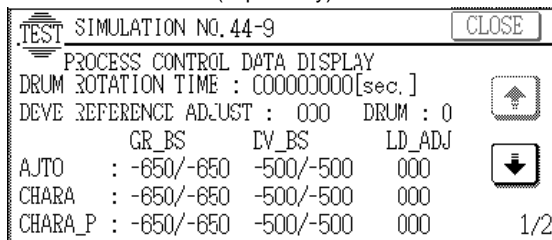

(AR-501/505)

DRUM ROTATION: Drum rotating time (sec)

DEVE MIXING TIME: Developer rotating time (sec)

DEVE REFERENCE ADJUST A: Toner concentration correction amount

DEVE REFERENCE ADJUST B: Toner concentration correction amount

DRUM: Drum identification result
 0: Others
 1: AR330DR/AR336DR/AR336DM/ARdR23; 10mm
 2: AR330DM/ARDR17; 3 x 4 x 3mm
 3: AR400DR/AR400DM; 15mm
 5: AR500DR/AR500DM/ARDR25; 5mm
 As other models except AR-501/505 do not recognize 5mm marking, "0" is displayed at that time.

GR_BS: Main charger grid voltage level (*1)

DV_BS: Developing bias voltage level (*1)
 (Display) *1 : Sim 8-1, 8-2 Set voltage/actual output voltage (including corrected amount)

LD_AD: Laser power correction power display (mW)
AUTO: Auto mode
CHARA: Character mode
CHARA_P: Character/photo mode
PHOTO: Photo mode
PRT: Printer mode
FAX: Fax mode (Japan only)

TEST SIMULATION NO. 44-9		CLOSE
PROCESS CONTROL DATA DISPLAY		
DRUM ROTATION TIME : 00000000[sec.]		↑
DEVE MIXING TIME : 00000000[sec.]		
DEVE REFERENCE ADJUST A : 000 DRUM : 0		↓
DEVE REFERENCE ADJUST B : 000		
GR_BS DV_BS LD_ADJ		
AUTO : -650/-650 -500/-500 000		1/2

TEST SIMULATION NO. 44-9		CLOSE
PROCESS CONTROL DATA DISPLAY		
CHARA : -650/-650 -500/-500 000		↑
CHARA_P : -650/-650 -500/-500 000		
PHOTO : -650/-650 -500/-500 000		↓
PRT : -650/-650 -500/-500 000		
		2/2

44 - 12

Purpose	Operation data output/Check (Display/Print)	
Function (Purpose)	Used to check the toner image patch density data in correction operation of the image forming section. (This simulation allows to check whether the correction is executed properly or not.)	
Section	Image process (Photoconductor/Developing/Transfer/Cleaning)	
Item	Data	Operation data (Machine condition)
Operation/Procedure	The latest developing bias correction data is displayed. The sensor detection level (density) in the toner image patch section/OPC drum base during the developing bias correction is displayed.	

DMLED: Drum marking sensor gain adjustment level
PCLD: Image density sensor gain adjustment level
DV_BS: The developing bias voltage level when forming PT2/BS2 of ID (1)
PT1/BS1: No. 1 toner image patch section/Drum base sensor detection level
PT2/BS2: No. 2 toner image patch section/Drum base sensor detection level
PT3/BS3: No. 3 toner image patch section/Drum base sensor detection level

ID (n) : Sequence number of correction operation

TEST SIMULATION NO. 44-12		CLOSE
DM DATA, PATCH/BASE DATA DISPLAY		
DMLED : 000 PCLD : 000 DV_BS : 000		↑
PT1/BS1 PT2/BS2 PT3/BS3		
ID(1) : 000/000 000/000 000/000		↓
ID(2) : 000/000 000/000 000/000		
ID(3) : 000/000 000/000 000/000		
ID(4) : 000/000 000/000 000/000		1/2

44 - 15

Purpose	Setting
Function (Purpose)	Used to set the correction values of various parameters (main charger grid voltage, laser beam power, developing bias voltage) in the image forming operation and image forming section correction for OPC drum type A. (AR-250/280/281/285/286/335/336/405 only)
Section	Image process (Photoconductor/Developing/Transfer/Cleaning)
Item	Operation
Operation/Procedure	Used to set various parameters of image forming operation and image forming section correction operation for drum type A.

1. Select the correction item with [↑], [↓] keys.
2. Enter the set value with the 10-key
3. Press the [OK] key. (The value entered in procedure 2 is set.)

DV BIAS: Developing bias base voltage (Equivalent to SIM 8-1 for Drum type B.) (500)
GRID BIAS: Main charger grid voltage (Equivalent to SIM 8-2 for drum type B.) (475)
LD POWER: Laser power (Equivalent to SIM 61-2 for drum type B.) For AR-2X1/3X1/4XX/250/XX6 series, set to "10" (default). For AR-230/250/285/330/335 series, set to "16."
PROCON DB: Base developing bias voltage in toner image patch forming (in developing bias correction) (Equivalent to SIM 44-5B) (500) (Correction value to SIM 44-5B)
PROCON GB: Base main charger grid voltage (Equivalent to SIM 44-5A in drum type B) (500) (Correction value to SIM 44-5A)
PROCON TARGET: Target image (reference) density level in developing bias voltage correction (Equivalent to SIM 44-4 4 in drum type B) (58)

Be sure to set to the specified value.

TEST SIMULATION NO. 44-15		CLOSE
DRUM CONTROL SET UP		
A: 500	A: 500 ;DV BIAS	↑
	B: 500 ;GRID BIAS	
	C: 16 ;LD POWER	↓
	D: 500 ;PROCON DB	
	E: 500 ;PROCON GB	
	F: 58 ;PROCON TARGET	OK

Note Be sure to set to the specified value. If not, the print image density may be disturbed.

46**46 - 2**

Purpose	Adjustment
Function (Purpose)	Used to adjust the copy density in the copy mode (binary/multi-value - auto, character and photo, photo mode). (The overall print density in each mode (all of the specified density set for each density level (display value)) can be adjusted in each mode.)
Item	Picture quality Density
Operation/Procedure	1. Select the print mode with [↑], [↓] keys. (The set value is highlighted.) 2. Enter the adjustment value with the 10-key.

- Press the [OK] key or the PRINT button.
The value entered in procedure 2 is set.
When the PRINT key is pressed, copying is performed.

(Note) When a set value (density adjustment value in density level 3) in the left column of the table below is changed with this simulation, the set value (the overall density level set value) in the right column is changed accordingly.

The parameters of the right and the left simulations and their adjustment items are the adjustment values in the same print mode.

The result of adjustment by the simulation executed at the last is reflected in actual printing.

The print density is normally adjusted by SIM 46-2.

To customize the print density for the density level display value according to the user's request, use the simulation in the right column. (Excluding auto mode)

(AR-230/280/285/330/335 series)

Binary mode

Set with SIM 46-2. Parameter to be changed	Linked simulation data
AE3.0 (AE)	
CH3.0 (Character)	Sim 46-9
MIX3.0 (Character/Photo)	Sim 46-10
PH3.0 (Photo)	Sim 46-11

Default: 100

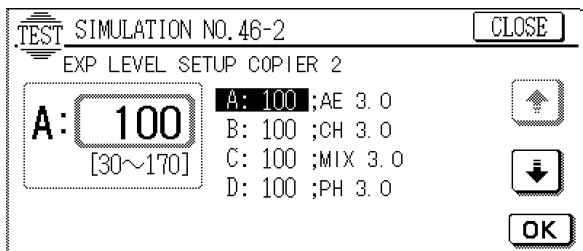

(AR-2X1/3X1/4XX/250/XX6 series)

	Set with SIM 46-2. Parameter to be changed	Linked simulation data
A	AE3.0 (AE)	
B	CH3.0 (Character)	Sim 46-9
C	MIX3.0 (Character/Photo)	Sim 46-10
D	PH3.0 (2)	Sim 46-11 (Photo error diffusion)
E	PH3.0 (256)	Sim 46-7 (Photo multi value dither) (Japan only)

* For EX, the above value E is disabled.

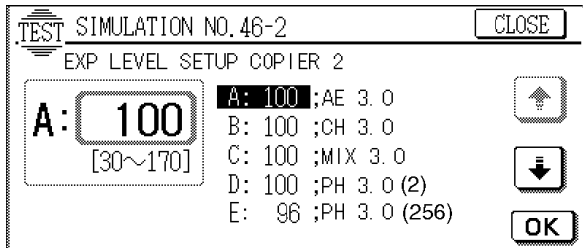

(AR-501/505)

	Set with SIM 46-2. Parameter to be changed	Linked simulation data
A	AE3.0 (AE)	
B	CH3.0 (Character)	Sim 46-9
C	MIX3.0 (Character/Photo)	Sim 46-10
D	PH3.0 (2)	Sim 46-11 (Photo error diffusion)

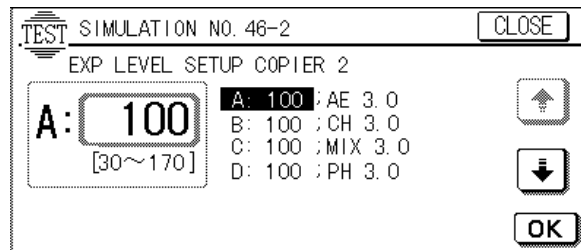

46 - 3

Purpose	Adjustment
Function (Purpose)	Used to adjust the copy density in the copy mode (multi value-auto, character and photo, photo mode). (The overall print density in each mode (all of the specified density set for each density level (display value)) can be adjusted in each mode.) (AR-250/280/285/330/335 only) (Japan only)

Item	Picture quality	Density
------	-----------------	---------

Operation/ Procedure 1. Select the print mode with [↑], [↓] key.
(The set value is highlighted.)

- Enter the adjustment value with the 10-key.
- Press the [OK] key or the PRINT button. (The value entered in procedure 2 is set.) When the PRINT button is pressed, copying is performed.

(Note) When a set value (density adjustment value in density level 3) in the left column of the table below is changed with this simulation, the set value (the overall density level set value) in the right column is changed accordingly.

The parameters of the right and the left simulations and their adjustment items are the adjustment values in the same print mode.

The parameters of the right and the left simulations and their adjustment items are the adjustment values in the same print mode. The result of adjustment by the simulation executed at the last is reflected in actual printing.

The print density is normally adjusted by SIM 46-2.

To customize the print density for the density level display value according to the user's request, use the simulation in the right column. (Excluding auto mode/SIM 46-4.)

(Multi value mode)

Sim46-3 Parameter set/changed by SM 46-3	Linked simulation data
AE3.0 (AE)	
CH3.0(Character)	Sim46-5
MIX3.0(Character/photo)	Sim46-6
PH3.0(Photo)	Sim46-7

Default: 100

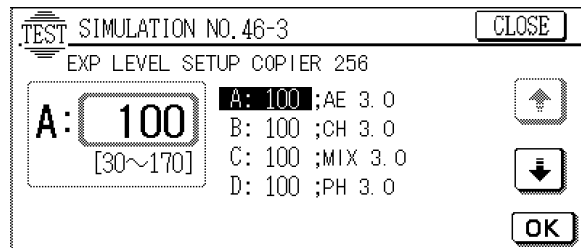

46 - 5

Purpose	Adjustment
Function (Purpose)	Used to adjust the print density for each density level (display value) in the copy mode (multi Auto mode). An arbitrary print density can be set for each density level (display value). (AR-250/280/285/330/335 only) (Japan only)

Item	Picture quality	Density
Operation/ Procedure	1. Select the density level with the density adjustment key. (The selected value is highlighted.) 2. Enter the adjustment value with the 10-key. 3. Press the ENTER key or the PRINT button. (The value entered in procedure 2 is set.)	

When the PRINT button is pressed, copying is performed. To customize the print density for the density level display value according to the user's request, use this simulation.

Default: 100

46 - 6

Purpose	Adjustment
Function (Purpose)	Used to adjust the print density for each density level (display value) in the copy mode (multi value-character, photo mode). An arbitrary print density can be set for each density level (display value). (AR-250/280/285/330/335 only) (Japan only)

Item	Picture quality	Density
Operation/ Procedure	1. Select the density level with the density adjustment key. (The selected value is highlighted.) 2. Enter the adjustment value with the 10-key. 3. Press the ENTER key or the PRINT button. (The value entered in procedure 2 is set.)	

When the PRINT button is pressed, copying is performed. To customize the print density for the density level display value according to the user's request, use this simulation.

Default: 100

46 - 7

Purpose	Adjustment
Function (Purpose)	Used to adjust the print density for each density level (display value) in the copy mode (multi value - photo mode). (Japan only)

Item	Picture quality	Density
Operation/ Procedure	1. Select the density level with the density adjustment key. (The selected value is highlighted.) 2. Enter the adjustment value with the 10-key. 3. Press the [ENTER] key or the [PRINT button]. (The value entered in procedure 2 is set.)	

When the [PRINT button] is pressed, copying is performed. To customize the print density for the density level display value according to the user's request, use this simulation.

Default: 100

46 - 9

Purpose	Adjustment
Function (Purpose)	Used to adjust the print density for each density level (display value) in the copy mode (binary - character mode).

Item	Picture quality	Density
Operation/ Procedure	1. Select the density level with the density adjustment key. (The selected value is highlighted.) 2. Enter the adjustment value with the 10-key. 3. Press the ENTER key or the PRINT button. (The value entered in procedure 2 is set.)	

When the PRINT button is pressed, copying is performed. To customize the print density for the density level display value according to the user's request, use this simulation.

Default: 100

46 - 10

Purpose	Adjustment
Function (Purpose)	Used to adjust the print density for each density level (display value) in the copy mode (binary - character, photo mode). An arbitrary print density can be set for each density level (display value).

Item	Picture quality
Operation/ Procedure	1. Select the print mode with [↑], [↓] keys. (The set value is highlighted.)

2. Enter the adjustment value with the 10-key.
 3. Press the [OK] key or the PRINT button. (The value entered in procedure 2 is set.)
 When the PRINT button is pressed, copying is performed.

To customize the print density in each mode according to the user's request, use this simulation to adjust the print density.

Default: 100

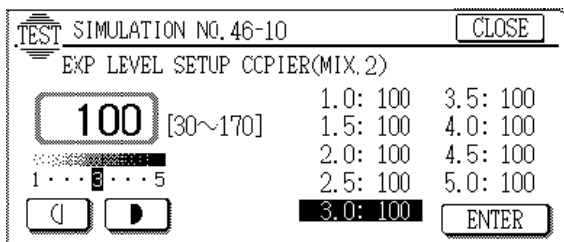

46 - 11

Purpose	Adjustment
Function (Purpose)	Used to adjust the print density for each density level (display value) in the copy mode (binary - photo mode). An arbitrary print density can be set for each density level (display value).
Item	Picture quality Density
Operation/ Procedure	1. Select the print mode with [↑], [↓] keys. (The set value is highlighted.)

2. Enter the adjustment value with the 10-key.
3. Press the [OK] key or the PRINT button. (The value entered in procedure 2 is set.)
When the PRINT button is pressed, copying is performed.

To customize the print density in each mode according to the user's request, use this simulation to adjust the print density.

Default: 100

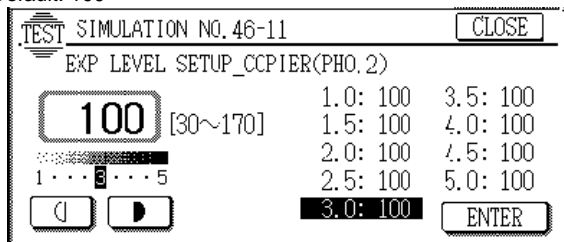

46 - 17

Purpose	Setting/Operation data output/Check (Display/Print)
Function (Purpose)	Used to execute shading correction and display the correction value.
Item	Operation
Operation/ Procedure	1. Select the set item with [↑], [↓] keys. (The selected item is highlighted.)

2. Press the [EXECUTE] key.
The shading correction is executed and the correction value is displayed.

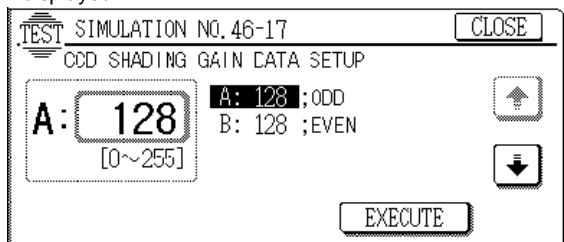

46 - 18

Purpose	Adjustment
Function (Purpose)	Used to adjust γ (density gradient) in each copy mode. (Target models: AR-2X1/3X1/4XX/250/XX6/5XX series)
Item	Picture quality Density

- | | |
|----------------------|--|
| Operation/ Procedure | 1. Select the print mode with [↑] key or [↓] key. (The display of the set value is highlighted.) |
|----------------------|--|
2. Enter the adjustment value with the 10-key.
 3. Press the [OK] key or the [PRINT] key.
The value entered in procedure 2 is set.
If the [PRINT] key is pressed, copying is performed.

With the following setting, the density gradient (γ) can be changed.

- A: Auto exposure mode (Center 64, 0 ~ 127)
- B: Character mode (Center 64, 0 ~ 127)
- C: Character, Photo mode (Center 64, 0 ~ 127)
- D: Photo mode (Error diffusion) (Center 64, 0 ~ 127)

(Note) The greater the value is, the greater the inclination is.

Default: 64

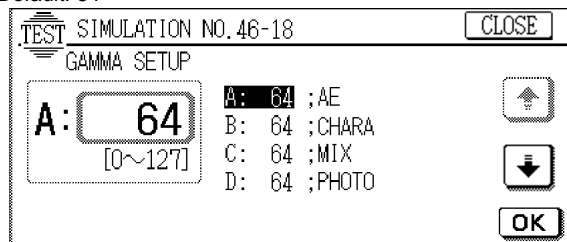

46 - 19

Purpose	Adjustment
Function (Purpose)	Used to adjust γ (density gradient) and set the density detection area in the auto copy mode and to set the image process mode in the photo copy mode. (Target models: AR-2X1/3X1/4XX/250/XX6/5XX series)
Item	Picture quality Density
Operation/ Procedure	1. Select the desired mode with [↑] key or [↓] key. (The display of the set value is highlighted.)

2. Enter the value with the 10-key.
3. Press the [OK] key or the [PRINT] key.
The value entered in procedure 2 is set.
 - A: Auto exposure mode setting
 - 1: Picture quality priority mode
 - 2: Toner consumption priority mode
 (Default: Japan = 1, EX = 2)
 - B: Auto exposure (Density detection) mode setting
 - 0: OFF (All surface density detection)
 - 1: ON (Image lead edge section density detection)
 (Default: 0) (AR-2X1/3X1/4XX/250/XX6 series only)
 - C: Photo mode image process setting
 - 1: Memory dither 8x8 mode
 - 2: Memory dither 8x8 mode
 - 3: Error diffusion photo mode
 (Default: Japan = 1, EX = 3)

(Note) Except for Japan, the above C is fixed to "3."
(AR-2X1/3X1/4XX/250/XX6)

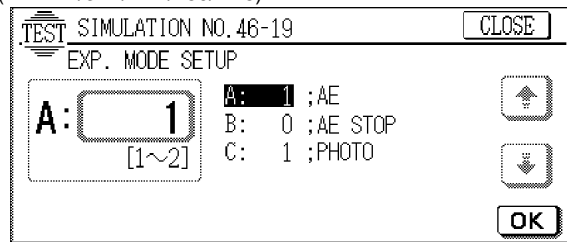

(AR-501/505)

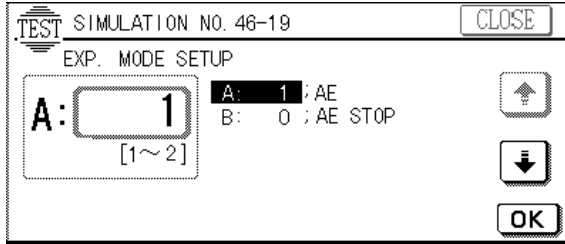
**46 - 20**

Purpose	Adjustment
Function (Purpose)	Used to adjust the copy density correction in the SPF copy mode for the document table copy mode. Adjustment is made so that the copy density is the same as that in the document table copy mode. (Target models: AR-2X1/3X1/4XX/250/XX6/5XX series)
Item	Picture quality Density
Operation/ Procedure	1. Select the print mode with [↑] key or [↓] key. (The display of the set value is highlighted.)

2. Enter the adjustment value with the 10-key.
3. Press the [OK] key or the [PRINT] key. (The value entered in procedure 2 is set.)

A: OC/SPF exposure correction value

Set range: 0 ~ 100

Center value: 50

(Default: 60)

(AR-501/505)

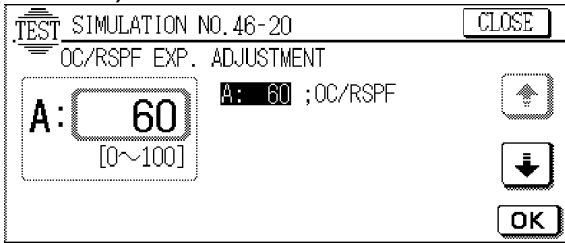

(Other models)

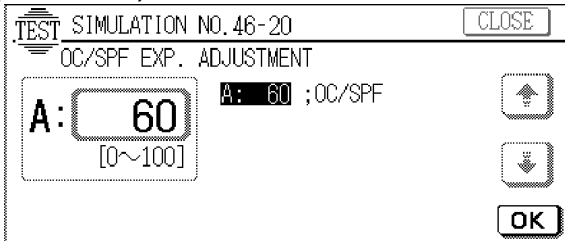
**48****48 - 1**

Purpose	Adjustment
Function (Purpose)	Used to adjust the copy magnification ratio (main scanning direction, sub scanning direction).
Section	ICU
Item	Picture quality
Operation/ Procedure	1. Select the adjustment mode with [↑], [↓] keys. 2. Enter the adjustment value with the 10-key.

3. Press the [OK] key. The value entered in procedure 2 is set.
 - a. Sub scan direction magnification ratio --- (SCAN)

The horizontal print magnification ratio (in the paper transport direction) of the image is adjusted by changing the scan speed in the paper transport direction.

- b. Main scan direction magnification ratio --- (F-R)
The vertical print magnification ratio (front frame to near frame) is adjusted in the image process section by the software operation.
- c. Sub scan direction magnification ratio adjustment value (When SPF is used) --- (SPF)
(When RSPF is used) --- (RSPF (SIDE1))
The horizontal print magnification ratio (in the paper transport direction) is adjusted by changing the document transport speed.
- d. Sub scan direction magnification ratio adjustment value (When RSPF is used) --- (RSPF (SIDE2))
The horizontal print magnification ratio (in the paper transport direction) is adjusted by changing the document transport speed.
(When the set value is changed by 1, the magnification ratio is changed by about 0.1%.)

Default: 50

(AR-501/505)

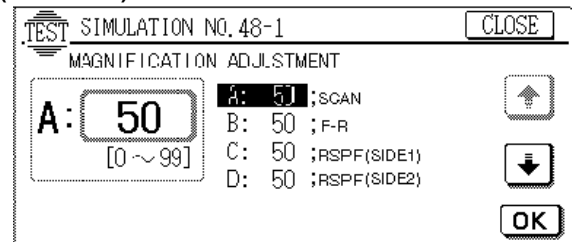

(Other models)

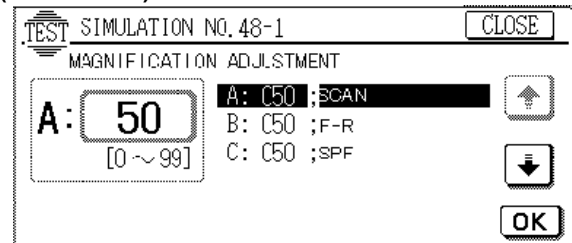
**50****50 - 1**

Purpose	Adjustment
Function (Purpose)	Used to adjust the copy image position and the void area (image loss) on the print paper in the copy mode. (The same adjustment can be made with SIM 50-2 (simple method).)
Item	Picture quality Image position
Operation/ Procedure	1. Select the adjustment item with [↑] [↓] keys. 2. Enter the adjustment value with the 10-key.

3. Press the [OK] key. (The adjustment value entered in procedure 2 is set.)

(RRC-A)

This set value is used to align the document image lead edge ad the scan image data lead edge in the document table scan mode.

After starting scanning, the image lead edge position is determined by using the scanner home position detection signal (MHPS) OFF timing as the reference.

RRC-A set value = Time (distance) from the output of the scanner home position detection signal (MHPS OFF) to the image lead edge position.

If this setting is not made properly, the image lead edge position (image loss) varies depending on the copy magnification ratio.

When the set value is increased, the image position is shifted in the advancing direction on the paper.

When the set value is changed by 1, the image lead edge position is varied.

(SPF)

This set value is used to align the document image lead edge position and the scan image data lead edge position in the SPF scan mode.

After starting scanning, the scan image lead edge position is determined by using the resist sensor detection signal (REGS ON) timing as the reference.

RRC-A set value = Time (distance) from the output (resist sensor detection signal (REGS ON) to the image lead edge position.

If this setting is not made properly, the image lead edge position (image loss) on the copy paper may vary depending on the copy magnification ratio.

When the set value is increased, the image position is shifted in the advancing direction of the copy paper.

When the set value is changed by 1, the image lead edge position is changed by about 0.1mm.

(RRC-B)

This set value is used to adjust the relative positions of the image position on the OPC drum and the copy paper.

This adjustment is made by adjusting the time from the output timing of the image lead edge signal (LD START signal) to RRC ON.

At the timing of LD START signal output, the print image is made on the OPC drum at an optional position with the laser beam.

Actually the RRC ON timing is determined as follows:

RRC ON timing = This set value (RRC-B) - Lead edge void set value (DEN-A)

When the set value is increased, the RRC ON timing is delayed, decreasing the lead edge void area.

When the set value is changed by 1, the lead edge void area is changed by about 0.17mm (about 0.21mm for AR-4XX series; about 0.24mm for AR-5XX series).

(Note)

The value of RRC-A must be properly set in advance to this adjustment.

(IMAGE LOSS)

This set value (timing adjustment value) is used to determine the lead edge image loss and the image lead edge reference position by using the scan image lead edge position set with RRC-A.

Effective print data is determined from the image lead edge position data scanned with this set value.

The image lead edge reference position on the document is at 2mm from the right of the document position alignment plate.

The effective image (effective image data) is determined by scanning the image.

When the set value is increased, the image loss becomes greater.

When the set value is changed by 1, the image loss is changed by about 0.1mm.

(DEN-A)

Used to set the timing for the RRC ON timing (paper timing) set with EEC-B.

RRC ON timing = (RRC-B) - Lead edge void set value (DEN-A)

When this adjustment value is changed, the print image position for the paper position is changed. As a result, the lead edge void area is also changed.

When the set value is increased, the RRC ON timing is advanced and the lead edge void area becomes greater.

When the set value is changed by 1, the lead edge void area is changed by about 0.1mm.

(DEN-B)

The rear edge void area is adjusted by controlling the effective print data length with the image lead edge signal (LD START signal) output from the ICU as the reference.

The effective image (effective image data) is determined when scanning the image.

When the set value is increased, the rear edge void area becomes great.

When the set value is changed by 1, the rear void area is changed by about 0.1mm.

(REAR LOSS (SPF))

Used to adjust the rear edge image loss in the SPF copy mode.

The greater the set value is, the greater the rear edge image loss is.

When the set value is changed by 1, the rear edge image loss is changed by about 1mm.

Adjust in the following sequence:

- 1) Set the image loss amount (IMAGE LOSS) and the paper lead edge void amount (DEN-A) to arbitrary values (20).
(0~99: 0.1mm/step)
- 2) Adjust the document scan start position (RRC-A) so that the actual copy image loss becomes the value set in procedure 1.
(0~99: 0.24mm/step) (0.29mm/step (AR-4XX/5XX series))
- 3) Adjust the resist roller clutch ON timing (RRC-B) so that the actual copy image loss becomes the value set in procedure 1.
(0~99: 0.17mm/step)
- 4) In the SPF copy mode, adjust the SPF image position (SPF) to the value set in procedure 1). (0~99, 0.1mm/step)
- 5) Adjust the rear edge image loss (REAR LOSS (SPF)) in the SPF copy mode. (0~20, 1mm/step) (AR-2X1/3X1/4XX/250/XX6 series only)
- 6) Adjust the rear edge void amount (DEN-B). (0~99: 0.1mm/step)

(AR-501/505)

TEST SIMULATION NO.50-1		CLOSE
LEAD EDGE ADJUSTMENT VALUE		
A: <input type="text" value="50"/>	A: 50 ; RRC-A	↑
[0 ~ 99]	B: 50 ; RRC-B	↓
	C: 30 ; DEN-B	
	D: 20 ; IMAGE LOSS	
	E: 50 ; DEN-A	OK

(Other models)

TEST SIMULATION NO.50-1		CLOSE
LEAD EDGE ADJUSTMENT VALUE		
A: <input type="text" value="50"/>	A: 50 ; RRC-A	↑
[0 ~ 99]	B: 50 ; RRC-B	↓
	C: 30 ; DEN-B	
	D: 50 ; SPF	
	E: 20 ; IMAGE LOSS	OK

TEST SIMULATION NO.50-1		CLOSE
LEAD EDGE ADJUSTMENT VALUE		
G: <input type="text" value="0"/>	C: 30 ; DEN-B	↑
[0 ~ 20]	D: 50 ; SPF	↓
	E: 20 ; IMAGE LOSS	
	F: 50 ; DEN-A	
	G: 0 ; REAR LOSS(SPF)	OK

50 - 2

Purpose	Adjustment
Function (Purpose)	Used to adjust the copy image position and the void area (image loss) on the print paper in the copy mode. (Simple adjustment) (This simulation allows the same simulation with SIM 50-1 more simply.)

Item	Picture quality	Image position
------	-----------------	----------------

Operation/Procedure	1. Select the adjustment item with [↑], [↓] keys. 2. Enter the adjustment value with the 10-key. 3. Press the [OK] key. (The value entered in procedure 2 is set.)
---------------------	--

IMAGE LOSS

DEN-A

DEN-B

} Same as SIM 50-1

This simulation is used to automatically adjust the image loss, the void area, and the image position by directly entering the paper lead edge and the image shift (in the unit of 0.1mm) in 400% (200% for the SPF) copy.

- Distance (Document table mode 400%) up to the scale of 10mm from the image lead edge a L3
- Distance from the paper lead edge to the image lead edge → L2
- Distance from the image lead edge to the scale of 10mm (SPF mode 200%) → L3

* The measurement value is multiplied with 10 to enter.

With the above procedure, the values of RRC-A and RRC-B in SIM 50-1 are automatically calculated and set. By directly setting the values (actual dimensions [mm] x 10) of IMAGE LOSS, DEN-A and DEN-B, the lead edge image loss, the lead edge void area, and the rear edge void area can be set.

By setting the image loss, DEN-A, DEN-B (actual dimension (mm) x 10) and REAR LOSS (SPF) (actual dimension (mm)) directly, the lead edge image loss, the lead edge void area, the rear edge void area and the rear edge image loss (SPF) can be set.

Code	Adjustment item	Adjustment value	Note
A	L1		When the image lead edge position varied depending on the copy magnification ratio, change the set value.
B	L2		
C	L3		When the image lead edge position varied depending on the copy magnification ratio, change the set value.
D	IMAGE LOSS	1.5 to 3.0mm	The greater the set value is, the greater the image loss is.
E	DEN-A	1.5 to 3.0mm	The greater the set value is, the greater the void area is.

Code	Adjustment item	Adjustment value	Note
F	DEN-B	1.5 to 3.0mm	The greater the set value is, the greater the void area is.
G	REAR LOSS (SPF)		The greater the set value is, the greater the image loss is. (AR-2X1/3X1/4XX/250/XX6 series only)

TEST SIMULATION NO. 50-2 CLOSE

LEAD EDGE ADJUSTMENT VALUE(CALC)

A: 320 [0~999]

B: 105 ;L2

C: 160 ;L3

D: 20 ;IMAGE LOSS

E: 20 ;DEN-A

OK

TEST SIMULATION NO. 50-2 CLOSE

LEAD EDGE ADJUSTMENT VALUE(CALC)

G: 0 [0~20]

C: 160 ;L3

D: 20 ;IMAGE LOSS

E: 20 ;DEN-A

F: 30 ;DEN-B

G: 0 ;REAR LOSS(SPF)

OK

50 - 5

Purpose	Adjustment	
Function (Purpose)	Used to adjust the print image position (top margin) on the print paper in the print mode.	
Item	Picture quality	Print area
Operation/Procedure	1. Enter the adjustment value with the 10-key. 2. Press the [EXECUTE] key to set the adjustment value entered in procedure 1.	

When the set value is increased, the top margin is increased.
When the set value is changed by 1, the top margin is changed by about 0.1mm.

Default: 50

TEST SIMULATION NO. 50-5 CLOSE

ADJUST PRINT EDGE POSITION

A: 50 [1~99]

A: 50 ;

B: 3 ; PAPER SELECT

EXECUTE

50 - 6

Purpose	Adjustment	
Function (Purpose)	Used to adjust the copy lead edge. (RSPF)	
Item	Picture quality	Print area
Operation/Procedure	1. Perform the 0C lead edge adjustment with SIM 60-1/2. (To use the 0C lead edge void quantity.)	

- Set the image loss quantity (LOSS (RSPF)) to a desired value. (0 - 99: 0.1 mm/step)
- Adjust the original scanning start position (RSPF (SIDE1)/RSPF (SIDE2)) so that the actual copy image loss quantity is as specified in procedure 2. (0 - 99: 0.1 mm/step)
- Adjust the rear edge void quantity (DEN-B). (0 - 99: 0.1 mm/step)
- Adjust the rear edge image loss quantity (REAR LOSS (SPF)) when the SPF is used. (0 - 20 mm/step)

There are five input items of the copy lead edge adjustment; LOSS (RSPF), RSPF (SIDE1), RSPF (SIDE 2), DEN-B, and REAR LOSS (RSPF). Select the desired item with [↑], [↓] keys to change the set value.

- Image loss quantity setup value (RSPF) --- (LOSS (RSPF))
Used to adjust the output timing of the image lead edge signal (SCAN signal) after starting scanning of the original. (0 - 99: Reference value 20)
- Original front surface scanning start position adjustment value -- (RSPF (SIDE1))
Used to set the time from the start of original feed to reaching at the exposure position. ([Front surface] (0 - 99: Reference value 50)
- Original back surface scanning start position adjustment value --- (RSPF (SIDE2))
Used to set the time from the start of original feed to reaching at the exposure position. [Back surface] (0 - 99: Reference value 50)
- Rear edge void quantity adjustment value --- (DEN-B)
Used to set the void quantity made at the rear edge of the original when the RSPF is used. (0 - 99: Reference value 30)
- Rear edge image loss quantity setup value --- (REAR LOSS (RSPF))
Used to set the image loss quantity at the rear edge when the RSPF is used. (0 - 20: Reference value 0)

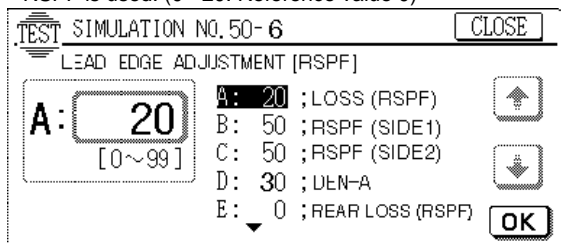

50 - 7

Purpose	Adjustment
Function (Purpose)	Used to adjust the copy lead edge (simple method). (RSPF)
Item	Picture quality Print area
Operation/ Procedure	1. Execute SIM 50-1/2 to adjust the 0C lead edge. (To adjust the 0C lead edge void quantity.) 2. Set the image loss quantity (LOSS (RSPF)) to the desired value. (0 - 99: 0.1 mm/step)

- Set all of L4/L5/L6 to 0.
- Make a 200% copy with the RSPF, and enter the shift quantity to L4/L5/L6. (0 - 999: 0.1 mm/step)
- Repeat procedure 4 until the paper rear edge void in an actual copy image becomes the value set in procedure 2.
- Adjust the rear edge image loss quantity (REAR LOSS (SPF)) when the SPF is used. (0 - 20: 1 mm/step)

There are five input items of the copy lead edge adjustment (simple method); L4, L5, L6, LOSS (RSPF), and REAR LOSS.

Select the desired item with [↑], [↓] keys in the touch panel to change the set value.

This simulation allows the lead edge adjustment by entering the lead edge shift at 200% directly.

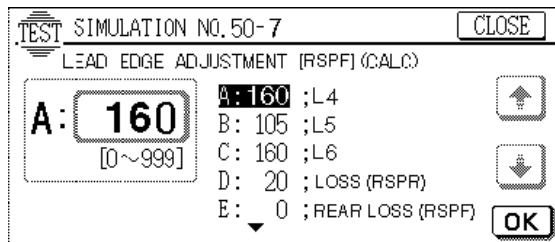

50 - 10

Purpose	Adjustment
Function (Purpose)	Used to adjust the print image center position. (Adjustment can be made for each paper feed section.)
Section	ICU
Item	Picture quality Image position
Operation/ Procedure	1. Select the adjustment item (paper feed section) with [↑], [↓] keys.

- Enter the adjustment value with the 10-key.
- Press the [OK] key to set the adjustment value entered in procedure 1.
When the set value is increased, shift is made forward. When decreased, backward.
When the set value is changed by 1, the shift is changed by about 0.1mm.

A, B, C, E, F, G, H : Default 50
D : Default 58

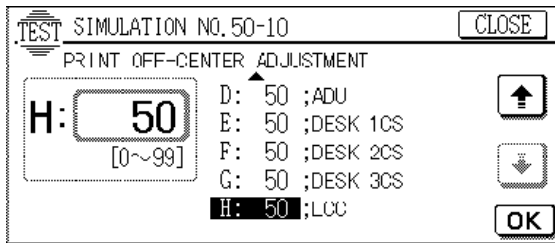
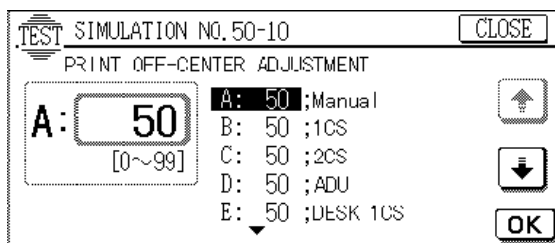

50 - 12

Purpose	Adjustment
Function (Purpose)	Used to adjust the print image center position. (Adjustment can be made for each document mode.)
Section	ICU
Item	Picture quality Image position
Operation/ Procedure	1. Select the adjustment item (paper feed section) with [↑], [↓] keys.

- Enter the adjustment value with the 10-key.
- Press the [OK] key to set the adjustment value entered in procedure 1.
When the set value is increased, shift is made forward. When decreased, backward.
When the set value is changed by 1, the shift is changed by about 0.1mm.

Default: 50

(AR-501/505)

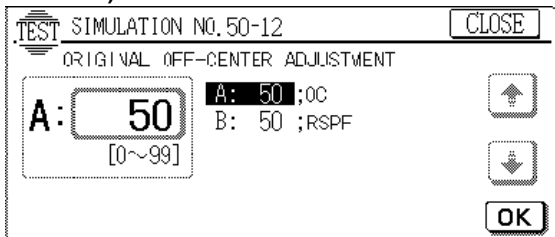

(Other models)

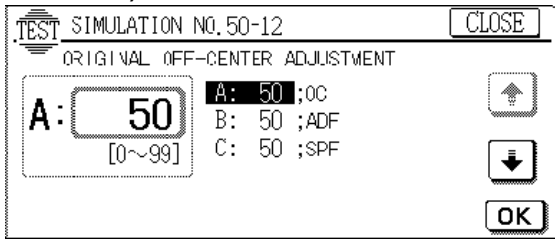

51

51 - 1

Purpose	Adjustment
Function (Purpose)	Used to adjust the OPC drum separation pawl ON timing.
Section	Image process (Photoconductor/Developping/Transfer/Cleaning)
Item	Operation
Operation/Procedure	1. Enter the adjustment value with the 10-key. 2. Press the [OK] key. (The value entered in procedure 1 is set.)

Time interval from the resist roller clutch (RRC) ON timing to the OPC drum separation pawl drive solenoid (PSPS) ON.
When the set value is increased, the timing is delayed. When the set value is changed by 1, the timing is changed by about 1.0msec.

(AR-250/280/281/285/286/335/336/405)

Default 310

(AR-501/505)

Default: 283

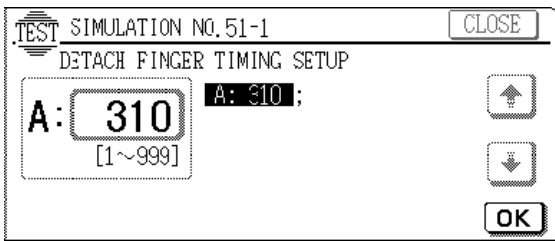

51 - 2

Purpose	Adjustment
Function (Purpose)	Used to adjust the contact pressure of paper onto the resist roller in each section (copier paper feed section, duplex paper feed section, SPF paper feed section). (When the print image position varies greatly for the paper or when a lot of paper jam troubles occur, the adjustment is required.)
Section	Paper transport (Discharge/Switchback/Transport)
Item	Operation
Operation/Procedure	1. Select the adjustment mode with [↑], [↓] keys. 2. Enter the adjustment value with the 10-key.

3. Press the [OK] key. (The value entered in procedure 2 is set.)

Used to set the resist roller clutch (RRC) ON timing.

When the set value is increased, the timing is delayed and the paper pressure onto the resist roller is increased. When the set value is changed by 1, the timing is changed by about 1.0msec.

- TRAY Copier and desk paper feed high speed transport resist amount adjustment (45) (Default)
- MANUAL Manual paper feed resist amount adjustment (31) (Default)
- LCC LCC paper feed high speed transport resist amount adjustment (45) (Default)
- ADU ADF paper feed resist amount adjustment (30) (Default)
- TRAY LOW Copier and desk feed low transport resist amount adjustment (35) (Default)
- LCC LOW LCC paper feed low transport resist amount adjustment (45) (Default)
- SPF SPF paper feed resist amount adjustment (50) (Default)
- RSPF (SIDE1) RSPF (SIDE1) paper feed resist amount adjustment
- RSPF (SIDE2) RSPF (SIDE2) paper feed resist amount adjustment

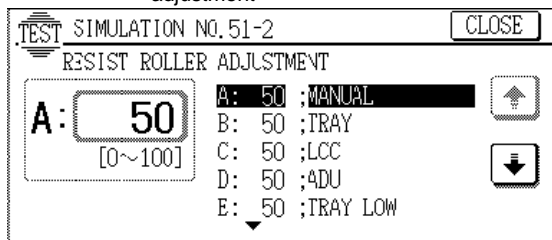

(AR-501/505 only)

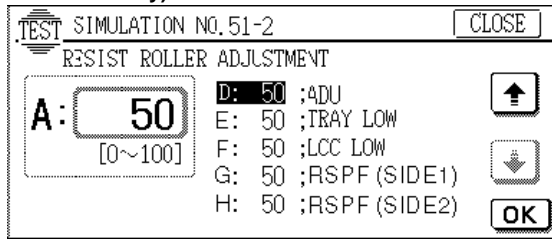

51 - 8

Purpose	Setting
Function (Purpose)	Used to set Enable/Disable of the drum separation pawl drive solenoid (PSPS) operation for each paper feed section (Manual paper feed, cassette 1, cassette 2, duplex module, desk cassette 1, desk cassette 2, desk cassette 3, LCC)
Section	Image process
Item	Operation
Operation/Procedure	1. When this simulation is executed, the current set value is displayed.

At that time, the item A-H can be selected with [↑], [↓] keys and the set value can be changed with the 10-key.

2. When [↑] and [↓] and OK keys are pressed, the currently set value is stored in the EEPROM.

			Default
A	Manual paper feed	0: Enable/1: Disable	0: Enable
B	Cassette 1	0: Enable/1: Disable	0: Enable
C	Cassette 2	0: Enable/1: Disable	0: Enable
D	Duplex module	0: Enable/1: Disable	0: Enable
E	Desk cassette 1	0: Enable/1: Disable	0: Enable
F	Desk cassette 2	0: Enable/1: Disable	0: Enable
G	Desk cassette 3	0: Enable/1: Disable	0: Enable
H	LCC	0: Enable/1: Disable	0: Enable

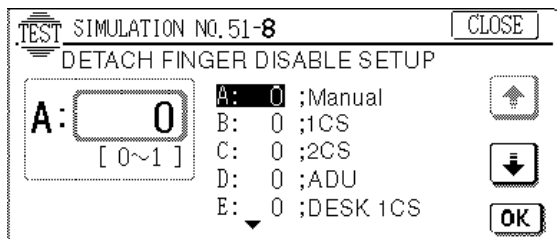
**52****52 - 1**

Purpose	Adjustment
Function (Purpose)	Used to adjust the duplex print mode stacking capability. (Used to adjust the stop position of the paper tray width direction alignment plate in the duplex unit. The adjustment is executed by changing the width direction alignment plate home position in the software.)
Section	Duplex
Item	Operation
Operation/Procedure	1. Select mode B with [↑], [↓] keys. 2. Select the paper feed mode with the 10-key.

3. Press the [EXECUTE] key.
4. Select mode A with [↑], [↓] keys.
5. Enter the adjustment value with the 10-key.
6. Press the [EXECUTE] key.

If there is no paper on the duplex tray, paper feed is performed in the paper feed mode selected in mode B and one sheet of paper is transported to the duplex tray. Then the value set in procedure 5 is set and the alignment plate is operated according to the home position corresponding to the set value.

When the set value is changed by "1", it is changed by about 0.2mm.

When the set value is increased, the alignment plate paper width is decreased.

The set value is in the range of ± 50 with 50 at the center.

Set item	A: Alignment plate adjustment value (Default: 50)
	B: Paper feed mode selection
	1: Manual
	2: Upper cassette
	3: Lower cassette
	4: Desk top cassette
	5: Desk middle cassette
	6: Desk bottom cassette
	7: LCC

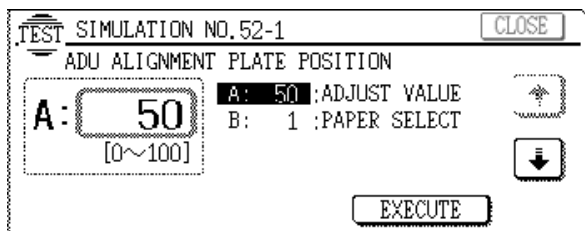
**53****53 - 1**

Purpose	Adjustment
Function (Purpose)	Used to adjust the document stop position in each operation mode of ADF/RADF. (Target model: AR-250/280/285/335/405)

Section	ADF/RADF
Item	Operation
Operation/Procedure	1. Select the adjustment mode with [↑], [↓] keys. 2. Enter the adjustment value with the 10-key.

3. Press the [OK] key.

The value entered in procedure 2 is set.

This is used to set the document transport belt stop timing.

NORMAL(S)	Normal paper front surface, stop position adjustment value
NORMAL(D)	Normal paper back surface, stop position adjustment value
THIN (S)	Thin paper front surface, stop position adjustment value
THIN (D)	Thin paper back surface, stop position adjustment value

Relations between the adjustment value and the document stop position (Varies depending on machines.)

08: ± 0.000 mm	00: - 8.000mm	09: + 1.000mm
	01: - 7.000mm	10: + 2.000mm
	02: - 6.000mm	11: + 3.000mm
	03: - 5.000mm	12: + 4.000mm
	04: - 4.000mm	13: + 5.000mm
	05: - 3.000mm	14: + 6.000mm
	06: - 2.000mm	15: + 7.000mm
	07: - 1.000mm	

Default: 8

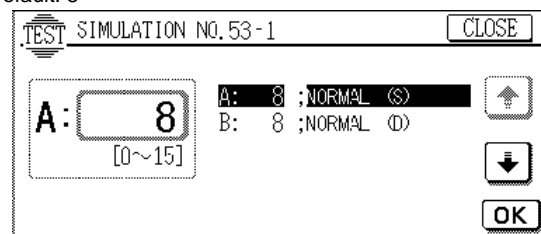
**53 - 2**

Purpose	Adjustment
Function (Purpose)	Used to adjust the optical sensor sensitivity in the ADF/RADF/RSPF.
Section	ADF/RADF/RSPF
Item	Operation
Operation/Procedure	1. The sensor names are displayed. Select the sensor to be adjusted with the key.

2. Press the [EXECUTE] key.

The adjustment of the sensor selected in procedure 1 is started. During execution of the adjustment, the [EXECUTE] key is highlighted. If the [EXECUTE] key is pressed under this state, the adjustment can be interrupted.

After completion of the adjustment, the COMPLETE display is shown.

(When AR-AF1/RF1 is installed)

REGIST (DFD) Resist sensor

TIMING (DTD) Timing sensor

REVERSE (RDD) Paper exit/reverse sensor

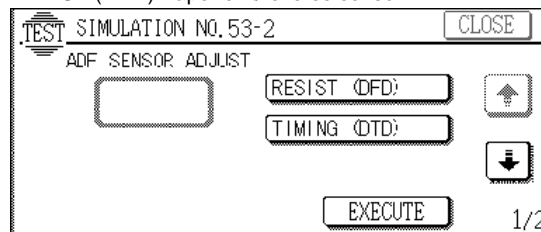

(When RSPF is installed)
 SEPARATE (SUNRIS) Post-separation sensor
 READ (RDS) Read sensor
 SWITCH (SBS) Switch-back sensor

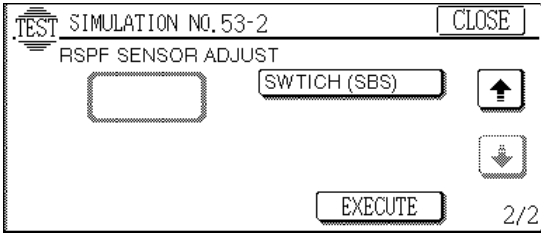
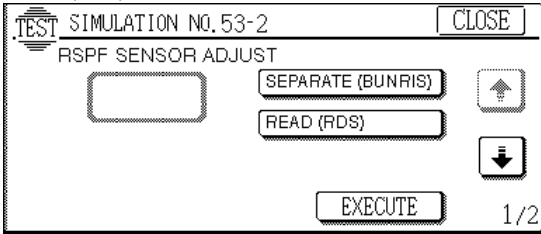

53 - 6

Purpose	Adjustment
Function (Purpose)	Used to adjust the RSPF width detection level. (AR-501/505 only)
Section	Image process
Item	Operation
Operation/ Procedure	1. Press "TRY VR (MIN)" key (touch panel) in Fig. 2 to close the RSPF tray guide to the minimum. Then Press the EXECUTE key to start the adjustment. During the adjustment, the EXECUTE key is highlighted. When the EXECUTE key is pressed under this state, the adjustment is interrupted.

When two or more operations are selected, the item which is displayed at the top is performed and the other items are canceled. The canceled items are returned to the normal display. After completion of the adjustment, the adjustment result is displayed with the adjustment item remained highlighted.

(Normal end)
 The menu of Fig. 4 is displayed for 3 sec, then the menu of Fig. 5 is displayed to complete the adjustment procedure. The adjustment result data is displayed with numerical figures.

(Abnormal end)
 The menu of Fig. 6 is displayed. IN this case, check the tray guide position again, and press the EXECUTE key to perform the sensor adjustment again.

2. Press "TRAY VR (MAX)" key (touch panel) to open the RSPF tray guide to the maximum. Then press the EXECUTE key to start the adjustment. During the adjustment, the EXECUTE key is highlighted. When the EXECUTE key is pressed under this state, the adjustment is interrupted.

When two or more operations are selected, the item which is displayed at the top is performed and the other items are canceled. The canceled items are returned to the normal display. After completion of the adjustment, the adjustment result is displayed with the adjustment item remained highlighted.

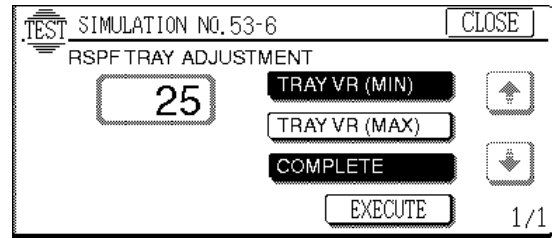
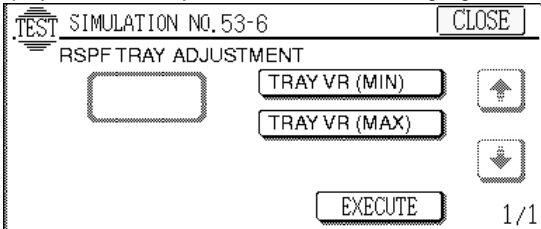

60

60 - 1

Purpose	Operation test/check
Function (Purpose)	Used to check the operation (read/write) of ICU (DRAM). (SIMM MEMORY/ONBOARD MEMORY)
Section	ICU
Item	Operation
Operation/ Procedure	1. Press the [EXECUTE] key to check the read/write operations.

2. After completion of the read/write operation check, the check result is displayed with OK or NG.

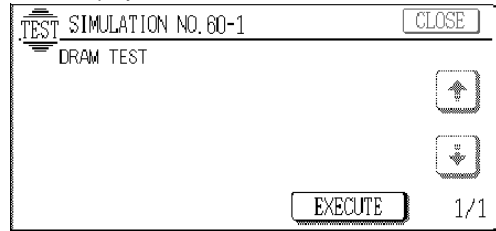

61

61 - 1

Purpose	Operation test/check
Function (Purpose)	Used to test the operation of the scanner (exposure) unit.
Section	Laser (Exposure)
Item	Operation
Operation/ Procedure	1. Press the [EXECUTE] key The scanner unit is started.

2. After completion of check operation, the result is displayed with OK or NG.

Used to check whether the sync signal (HSYNC/) is normally outputted or not by operating the laser (exposure) unit (laser motor rotation, laser emission).

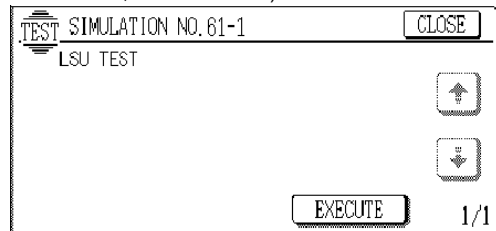

61 - 2

Purpose	Adjustment
Function (Purpose)	Used to adjust the scanner (exposure) laser power (absolute value) in the copy mode.
Section	Laser (Exposure)
Item	Operation
Operation/ Procedure	(AR-230/280/285/330/335 series) All must be set to "16."

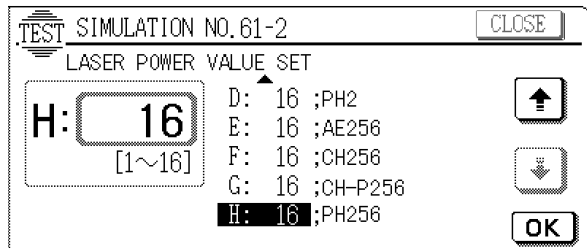
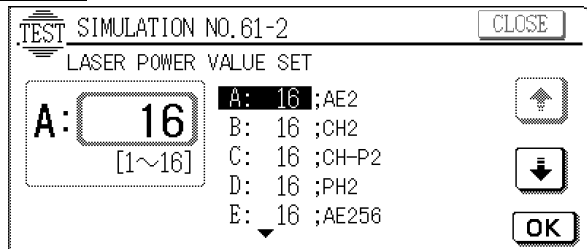

(AR-2X1/2X6/3X1/3X6 series)
Set all to "7" except for PH256.

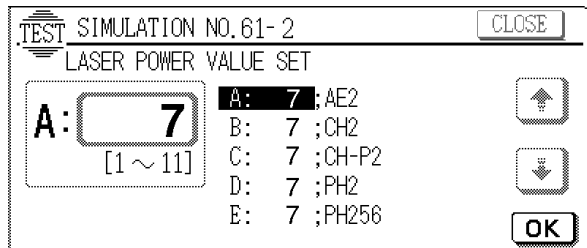

(AR-4XX series)
Set all to "5" except for PH256.

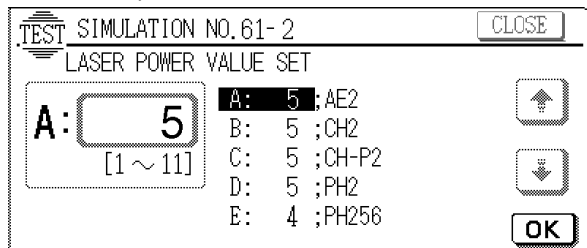

(AR-501/505)
All must be set to "5."

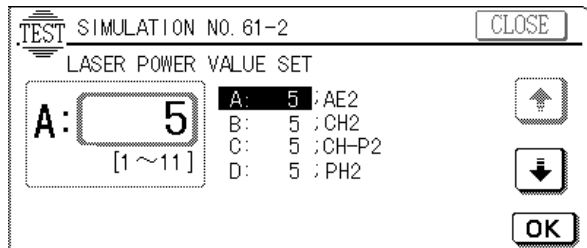

61 - 4

Purpose	Adjustment
Function (Purpose)	Used to adjust the scanner (exposure) laser power (absolute value) in the printer mode. (For Photoconductor type B)
Section	Laser (Exposure)
Item	Operation
Operation/ Procedure	(AR-230/280/285/330/335 series) Set all the values to the default value 16.

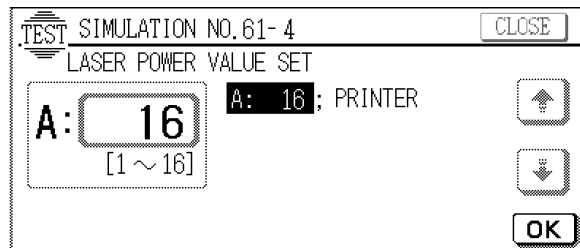

(AR-2X1/2X6/3X1/3X6)
Set all the values to the default value 7.
(AR-4XX/501/505 series)
Set all the values to the default value 5.

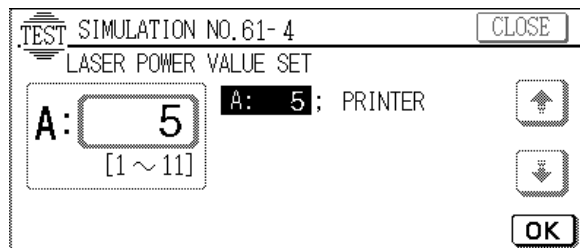

62

62 - 1

Purpose	Setting/Data clear
Function (Purpose)	Used to format the hard disk. (Target models: AR-250/280/285/335)(Models with the hard disk installed only)
Section	Memory
Item	Others
Operation/ Procedure	1. Press the [EXECUTE] key. The display for reconfirmation to clear or not is shown.

2. Select YES/NO to format.
YES: Formatting is performed.
NO: Formatting is not performed.
3. Press YES.
Formatting is performed. After completion, the result is shown with OK or NG.
This procedure is necessary when the hard disk is replaced. If NG is displayed, it means a hard disk trouble.

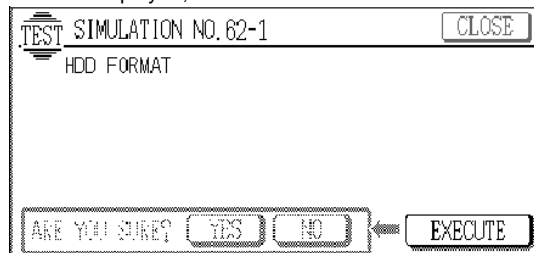

62 - 2

Purpose	Operation test/check
Function (Purpose)	Used to check the operation (read/write) of the hard disk. (Target models: AR-250/280/285/335)(Models with the hard disk installed only.) (Partial check)
Section	Memory
Item	Operation
Operation/ Procedure	1. Press the [EXECUTE] key to start the read/write operation check.

2. After completion of the read/write operation check, the result is displayed with OK or NG.
If NG is displayed, it means a hard disk trouble.

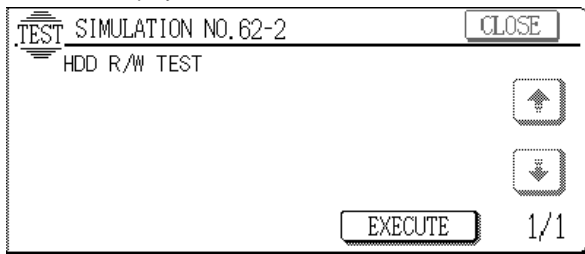

62 - 3

Purpose	Operation test/check
Function (Purpose)	Used to check the operation (read/write) of the hard disk. (Target models: AR-250/280/285/335) (Only the models with a hard disk) (All area check)
Section	Memory
Item	Operation
Operation/ Procedure	1. Press the [EXECUTE] key to start the read/write operation check.

2. After completion of the read/write operation check, the result is displayed with OK or NG.
If NG is displayed, it means a hard disk trouble.

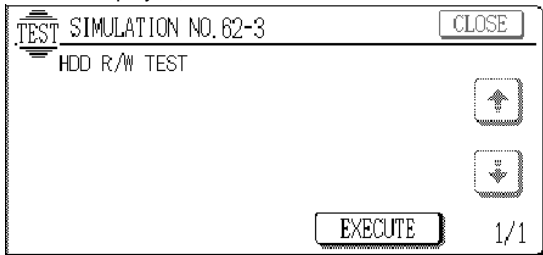

63

63 - 1

Purpose	Operation data output/Check (Display/Print)
Function (Purpose)	Used to check the result of shading correction. (The shading correction data are displayed.)
Section	Scanner (Exposure)
Item	Operation
Operation/ Procedure	Used to display the result of latest shading correction. The displayed page can be shifted with [↑], [↓] keys.

- ODD/EVEN OFFSET: Difference between the average detection level and the max. detection level
- BLACK OFFSET: Dark component (average level)

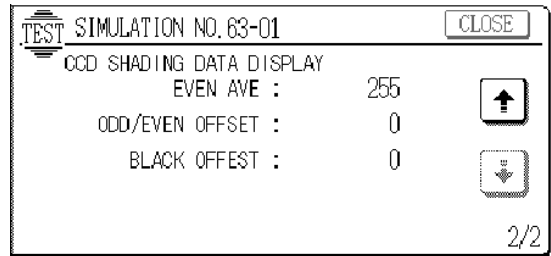
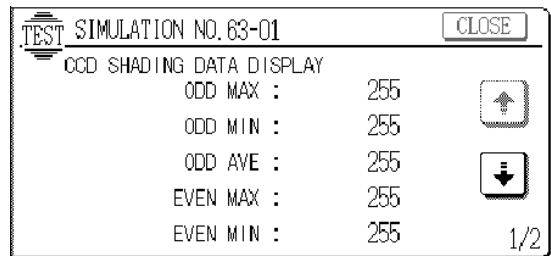

63 - 7

Purpose	Adjustment
Function (Purpose)	Used to adjust the white plate scanning start position in the shading white correction. (AR-501/505 only)
Section	Scanner
Item	Operation

1. When this simulation is executed, the currently set value is displayed.
At that time, the set value can be changed with the 10-key.
2. When the OK key is pressed, the currently set value is stored in the EEPROM.

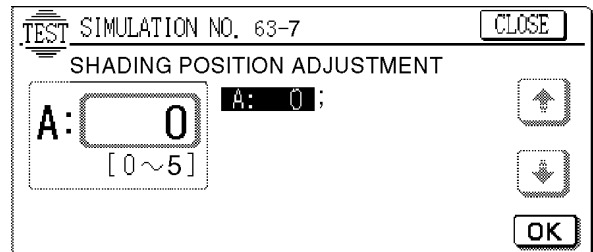

64

64 - 1

Purpose	Operation test/check
Function (Purpose)	Used to check the operation of the printer function (auto print operation). (Print pattern, paper feed mode, print mode, the number of sheets, and the density can be set to an arbitrary value.)
Section	Printer
Item	Operation

1. Select the item with [↑], [↓] keys.
2. Enter the print conditions with the 10-key. (There are 29 kinds of print patterns.)
3. Press the [EXECUTE] Key.
Printing is executed under the condition set with procedure 2.

- A: Self print pattern ----- 1.ALL 1BY1(V)
- B: Density level 2.ALL 1BY1(H)
- C: Self print number setting 3.ALL 1BY2(V)

- D: Picture quality mode
 - 1: Auto
 - 2: Character
 - 3: Character/Photo
 - 4: Photo
 - E: Paper feed source select
 - 1: Manual
 - 2: Upper cassette
 - 3: Lower cassette
 - 4: Desk top cassette
 - 5: Desk middle cassette
 - 6: Desk bottom cassette
 - 7: LCC
 - F: Duplex print select
 - 0: Single
 - 1: Duplex
- 4.ALL 1BY2(H)
 - 5.ALL 1BY3(V)
 - 6.ALL 1BY3(H)
 - 7.ALL 1BY4(V)
 - 8.ALL 1BY4(H)
 - 9.ALL 1BY5(V)
 - 10.ALL 1BY5(H)
 - 11.ALL 2BY2(V)
 - 12.ALL 2BY2(H)
 - 13.ALL 2BY3(V)
 - 14.ALL 2BY3(H)
 - 15.BLACK *1
 - 16.GRAY SCALE 120/4(V) *3 *4
 - 17.GRAY SCALE 120/4(H) *2 *4
 - 18.GRAY SCALE 250/8(V) *2
 - 19.GRAY SCALE 250/8(H) *2
 - 20.DOT PATTERN 250/2(V) *1
 - 21.GRAY SCALE 250/2(H) *3 *4
 - 22.SQUARE
 - 23.SLANT 45
 - 24.SLANT 26.6
 - 25.SLANT 63.4
 - 26.ID/BG
 - 27.DOT PATTERN 12.5%
 - 28.DOT PATTERN 25%
 - 29.DOT PATTERN 50%
 - 30.SMOOTHING CHECK PATTERN

- *1: In AR-2X1/3X1/4XX/250/XX6 series, only Japan specification model allows density change.
- *2: In AR-2X1/3X1/4XX/250/XX6 series, only Japan specification model works.
- *3: AR-2X1/3X1/4XX/250/XX6 series cannot work.
- *4: AR-501/505 cannot work.

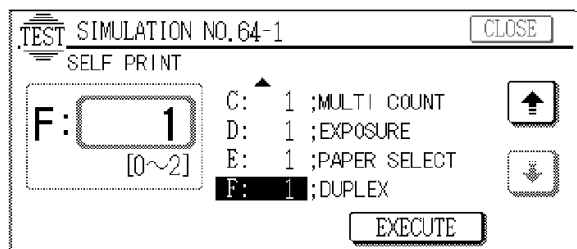
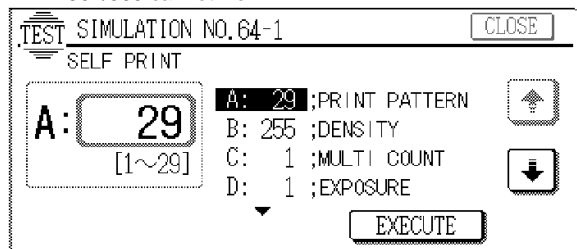

65

65 - 1

Purpose	Adjustment
Function (Purpose)	Used to adjust the touch panel (LCD display) detecting position.

Section	Operation (Display/Operation key)
Operation/ Procedure	Touch the four cross marks. The coordinates at the pressed point are set.

When the coordinates are properly set, the display turns to gray and returns to the simulation sub code entry screen.
In case of an abnormality, it returns to the input display.

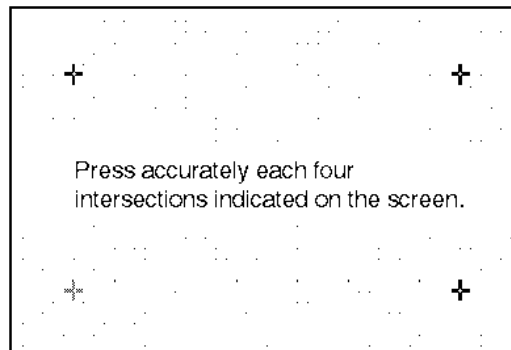

65 - 2

Purpose	Operation data output/Check (Display/Print)
Function (Purpose)	Used to check the result of the touch panel (LCD display) detecting position adjustment. (The coordinates are displayed.)
Section	Operation (Display/Operation key)
Operation/ Procedure	When the touch panel is pressed, the AD value in each of X and Y directions at that point and the coordinate values are displayed in () as well as the coordinate values of each point.

It is based on the coordinates set with SIM 65-1.

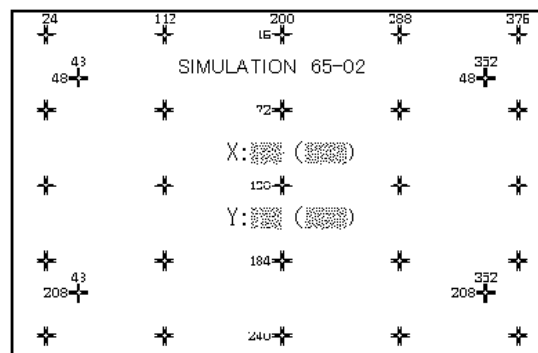

67

67 - 1

Purpose	Operation test/check
Function (Purpose)	Used to check the printer PWB memory operation (read/write). (When replacing the PWB with a new one, this check must be performed.)
Section	Printer
Item	Data
Operation/ Procedure	1. When SIM 67-1 menu is displayed, the operation check of all memory (DRAM, SIMM1, SIMM2) of the printer section is started.

2. For the RAM the operation check of which is started, "-----" display is changed to "CHECKING." When checking is completed, the check result is displayed with "OK" or "NG." When SIMM is inserted, the memory capacity is also displayed as "OK(16MB)."

TEST SIMULATION NO. 67-01		CLOSE
MEMORY R/W CHECK		
DRAM	:-----	↑
SIMM1	:-----	
SIMM2	:-----	↓
		1/1

TEST SIMULATION NO. 67-01		CLOSE
MEMORY R/W CHECK		
DRAM	:0K	↑
SIMM1	:0K(16MB)	
SIMM2	:CHECKING	↓
		1/1

67 - 2

Purpose	Operation test/check
Function (Purpose)	Used to check the printer parallel I/F operation. (This simulation is used only for production, and a special tool is required. Not available in the market.)
Section	Printer
Item	Operation Interface/Communication
Operation/Procedure	

TEST SIMULATION NO. 67-02		CLOSE
CENTRO PORT CHECK		
CENTRO PORT	:READY	
		EXECUTE

67 - 3

Purpose	Adjustment
Function (Purpose)	Used to adjust the printer parallel I/F ACK signal width.
Section	Printer
Item	Operation Interface/Communication
Operation/Procedure	1. Enter the ACK signal width of parallel I/F with the 10-key.

* Set range: 0 ~ 255 (*50ns)
Default: 10

2. When the [OK] key is pressed, the value set in procedure 1) is set.

TEST SIMULATION NO. 67-03		CLOSE
CENTRO ACK WIDTH ADJUSTING		
A:	0	↑
	[0~255]	
		↓
		OK

67 - 11

Purpose	Adjustment
Function (Purpose)	Used to set YES/NO of the printer parallel I/F SELECT IN signal.
Section	Printer
Item	Operation Interface/Communication
Operation/Procedure	1. Set ON/OFF of the SELECT IN signal ON/OFF of parallel I/F with the 10-key.

* Set range: 0 ~ 1 (0: ON, 1: OFF)
Default: 0/LI

2. When the [ON] key is pressed, the set value set in procedure 1) is set.

TEST SIMULATION NO. 67-11		CLOSE
SELECT-IN SETTING (0: ON 1: OFF)		
A:	0	↑
	[0~1]	
		↓
		OK

67 - 12

Purpose	Data transfer/Copy
Function (Purpose)	Used to write data into the printer flash memory.
Section	Printer
Item	Picture quality
Operation/Procedure	1. With the power OFF, change the printer PWB jumper connection to allow writing into the flash memory.

2. Enter SIM 67-12 mode, and wait until "-----" display is changed to "READY."
3. Send data from PC.
- 1) The display of the item to be rewritten is changed in the sequence of "RECEIVE," "SUM," "ERASE," "BLANK," and "WRITE" and rewriting is performed.
 - 2) The result of rewriting is displayed with "OK" or "NG."
- (Note) In case of an error, "ERROR!!! Exit sub Menu" is displayed.
In that case, press the interrupt key to exit from SIM 67-12 mode. If the machine still waits for data from PC, stop data sending.

4. Change the jumper connection of the printer PWB again to disable writing to the flash memory.

TEST SIMULATION NO. 67-12		CLOSE
FLASH MEMORY WRITING		
PS KANJI FONT	:READY	↑
ESC/P KANJI FONT	:READY	
BOOT ROM	:READY	↓
PROGRAM & FONT	:READY	
		1/1

67 - 13

Purpose	Data transfer/Copy
Function (Purpose)	Used to check the printer flash memory data.
Section	Printer

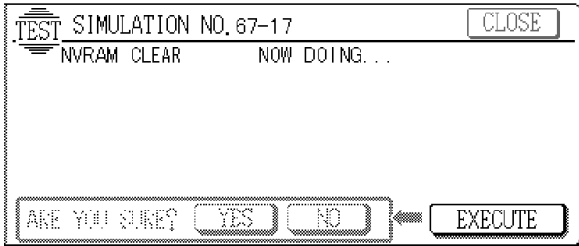
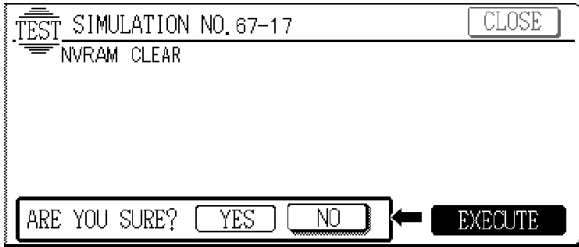
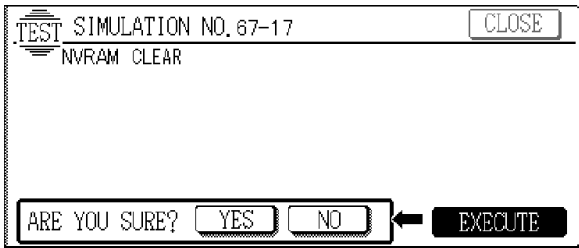

68

68 - 1

Purpose	Operation test/check
Function (Purpose)	Used to check the operation of infrared communication I/F (Zaurus link) and the related circuit. (Target models: AR-F230/S280/F280S/F280R/S330)(Japan models only)
Section	Interface
Item	Operation
Operation/Procedure	Press the [EXECUTE] key. The following checks are performed sequentially.

1. ASK/IrDA modulation LSI oscillation test
2. ASK modulation /IrDA modulation select test
3. ASK9600bps send/receive test
4. ASK19200bps send/receive test
5. IrDA9600bps send/receive test
6. IrDA115Kbps send/receive test

After completion of checking, if there is no abnormality, OK is displayed. If there is any abnormality, NG is displayed.

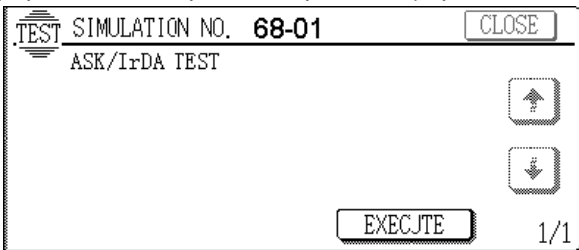

Note Japan only

69

69 - 1

Purpose	Check
Function (Purpose)	Used to check the input/output by connecting channels A and B of SCSI with the SCSI cable.
Section	Interface
Item	Operation
Operation/Procedure	1. When the EXECUTE key is pressed, the SCSI input/output check is performed.

2. After checking the SCSI input/output, the results are shown as shown in Fig. 3 and Fig. 4.

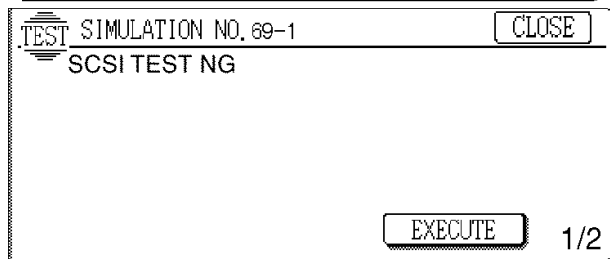
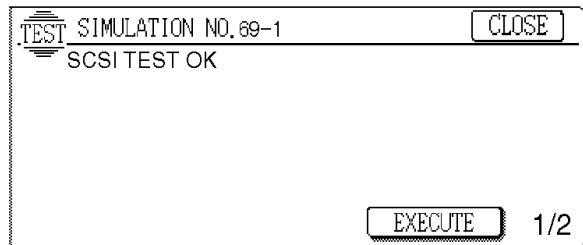
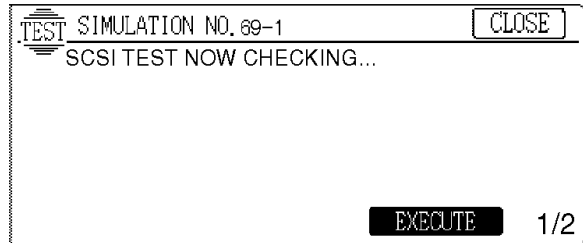
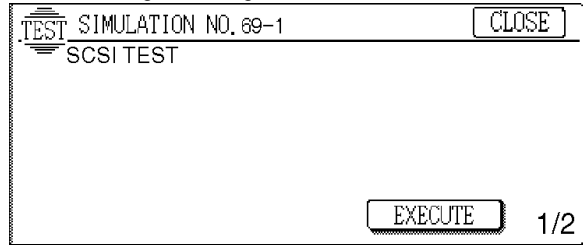

[8] DISASSEMBLY, ASSEMBLY, MAINTENANCE

1 Maintenance table

A. AR-250/280/281/285/286/335/336

5 Check (Check, clean, replace or adjust according to necessity.)

○ Cleaning ▲ Change △ Adjustment ☆ Lubrication □ Installing position change

Unit/Option name	Part name	Call	80K	160K	240K	320K	Remark	
Drum section	OPC Drum	Drum		×	▲	×	▲	To be factory attached
	Drum	Cleaner Blade		▲	▲	▲	▲	
		Drum mark sensor		○	○	○	○	
		Drum destiny sensor		○	○	○	○	
		Drum separation pawl		▲□	▲	▲□	▲	Change the installing position at every 80 K
		Toner reception seal		▲	▲	▲	▲	
		Toner reception auxiliary blade		○	○	○	○	
	TC / AC	Charger wire	(○)×	▲	▲	▲	▲	
		Charger case	○	○	○	○	○	
		Discharge Lamp	Discharge Lamp	○	○	○	○	
	Main charger	Charging plate (Saw blade)	○	▲	▲	▲	▲	
		Screen grid	(○)×	▲	▲	▲	▲	
Developing section	Developer Box	DV seal		×	▲	×	▲	
		DSD collar		○	○	○	○	
		DV side seal F		×	▲	×	▲	
		DV side seal R		×	▲	×	▲	
	Developer	Developer		▲	▲	▲	▲	To be charged at the time of installation
	Toner cartridge	Toner cartridge						To be charged at the time of installation / To be replaced by user about 17.5 K
	Waste toner bottle	Waste toner bottle	×					To be replaced by user about every 40 K
Optical section	Mirror base unit	Mirror	○	○	○	○	○	
		Pulley		×	×	×	×	
	Copy lamp unit	Reflector	○	○	○	○	○	
		Mirror	○	○	○	○	○	
	Rail	Rail		☆	☆	☆	☆	
	Glass	Table glass	○	○	○	○	○	
		Dust proof glass	○	○	○	○	○	
		White reference glass	○	○	○	○	○	
	Scanner	Lens	○	○	○	○	○	
		Sensors	○	○	○	○	○	
		Drive belt		×	×	×	×	
		Drive wire		×	×	×	×	
	OC	OC	○	○	○	○	○	
Paper feed section	Manual feed tray	Rollers	(○)×	×	×	×	×	[Note 1]
		Torque limiter	×	×	×	×	×	[Note 1]
	Paper tray	Rollers	(○)×	×	×	×	×	[Note 1]
		Brake spring	×	☆	☆	☆	☆	
		Torque limiter	×	×	○☆	×	○☆	
Transport section	Transport	Transport rollers	(○)×	○	○	○	○	
		Resist roller	(○)×	○	○	○	○	
Suction	Suction belt	(○)×	○	○	○	○		
Fusing section	Fusing unit 1	Upper heat roller	(○)×	(○)×	▲	(○)×	▲	
		Lower heat roller	(○)×	(○)×	▲	(○)×	▲	
		Upper separation pawl	(○)×	▲	▲	▲	▲	
		Lower separation pawl	(○)×	▲	▲	▲	▲	
		Insulation bush		×	×	×	×	
	Fusing unit 2	Thermistor		×	×	×	×	
		Upper heat roller gear		☆	▲	☆	▲	
Paper exit section	2 Tray paper exit unit	Gears		☆	☆	☆	☆	
		Paper exit follower roller	×	☆	☆	☆	☆	
Drive section		Transport rollers	(○)×	○	○	○	○	
		Gears	☆	☆	☆	☆	☆	(Specified positions)
Filters	Print Quality	Belts				×		
				▲	▲	▲	▲	
		×	×	×	×	×		

[Note 1] Rough guide of replacement intervals

The rollers should be replaced, using the values indicated by the counter of each paper feed port as a rough guide.

- 500-sheets cassette: 80 K or 2 years (this also applies to built-in 500-sheets container.)
- Manual feed tray: 40 K or 2 years
- Torque limiter of Manual feed tray: 120 K or 2 years

B. AR-405

5 Check (Check, clean, replace or adjust according to necessity.)

○ Cleaning ▲ Change △ Adjustment ☆ Lubrication □ Installing position change

Unit/Option name	Part name	Call	90K	180K	270K	360K	Remark	
Drum section	OPC Drum	Drum	×	▲	×	▲	To be factory attached	
	Drum	Cleaner Blade		▲	▲	▲	▲	
		Drum mark sensor		○	○	○	○	
		Drum destiny sensor		○	○	○	○	
		Drum separation pawl		▲□	▲	▲□	▲	Change the installing position at every 90 K
		Toner reception seal		▲	▲	▲	▲	
		Toner reception auxiliary blade		○	○	○	○	
		Cleaner side seal F/R	×	×	×	×	×	
	TC / AC	Charger wire	(○)×	▲	▲	▲	▲	
		Charger case	○	○	○	○	○	
	Discharge Lamp	Discharge Lamp		○	○	○	○	
	Main charger	Charging plate (Saw blade)	○	▲	▲	▲	▲	
		Screen grid	(○)×	▲	▲	▲	▲	
	Developing section	Developer Box	DV seal		×	▲	×	▲
DSD collar				○	○	○	○	
DV side seal F				×	▲	×	▲	
DV side seal R				×	▲	×	▲	
Developer		Developer		▲	▲	▲	▲	To be charged at the time of installation
Toner cartridge		Toner cartridge						To be charged at the time of installation / To be replaced by user about 22 K
Waste toner bottle		Waste toner bottle	×					To be replaced by user about every 40 K
Optical section	Mirror base unit	Mirror	○	○	○	○	○	
		Pulley		×	×	×	×	
	Copy lamp unit	Refractor	○	○	○	○	○	
		Mirror	○	○	○	○	○	
		Rail		☆	☆	☆	☆	
	Glass	Table glass	○	○	○	○	○	
		Dust proof glass	○	○	○	○	○	
		White reference glass	○	○	○	○	○	
	Scanner	Lens	○	○	○	○	○	
		Sensors	○	○	○	○	○	
		Drive belt		×	×	×	×	
		Drive wire		×	×	×	×	
OC	OC	○	○	○	○	○		
Paper feed section	Manual feed tray	Rollers	(○)×	×	×	×	×	[Note 1]
		Torque limiter	×	×	×	×	×	[Note 1]
	Paper tray	Rollers	(○)×	×	×	×	×	[Note 1]
		Brake spring	×	☆	☆	☆	☆	
	Torque limiter	×	×	○☆	×	○☆		
Transport section	Transport	Transport rollers	(○)×	○	○	○	○	
		Resist roller	(○)×	○	○	○	○	
	Suction	Suction belt	(○)×	○	○	○	○	
Fusing section	Fusing unit 1	Upper heat roller	(○)×	(○)×	▲	(○)×	▲	
		Lower heat roller	(○)×	(○)×	▲	(○)×	▲	
		Upper separation pawl	(○)×	▲	▲	▲	▲	
		Lower separation pawl	(○)×	▲	▲	▲	▲	
		Insulation bush		×	×	×	×	
	Fusing unit 2	Thermistor		×	×	×	×	
		Upper heat roller gear		☆	▲	☆	▲	
	Gears		☆	☆	☆	☆		
Paper exit section	1 Tray paper exit unit	Paper exit follower roller	×	☆	☆	☆	☆	
		Transport rollers	(○)×	○	○	○	○	
			(○)×	○	○	○	○	
Drive section		Gears	☆	☆	☆	☆	(Specified positions)	
		Belts				×		
Filters			▲	▲	▲	▲		
TC		×	×	×	×	×		
Print Quality		×	×	×	×	×		

[Note 1] Rough guide of replacement intervals

The rollers should be replaced, using the values indicated by the counter of each paper feed port as a rough guide.

- 500-sheets cassette: 80 K or 2 years (this also applies to built-in 500-sheets container.)
- Manual feed tray: 40 K or 2 years
- Torque limiter of Manual feed tray: 120 K or 2 years

C. AR-501/505

5 Check (Check, clean, replace or adjust according to necessity.)

○ Cleaning ▲ Change △ Adjustment ☆ Lubrication □ Installing position change

Unit/Option name	Part name	When calling	125K	250K	375K	500K	Remark	
Drum peripheral	Drum		×	▲	×	▲	Installed when shipping (Alldestinations)	
	Cleaner blade		▲	▲	▲	▲		
	Toner reception seal		▲	▲	▲	▲		
	Cleaner side seal F/R		×	×	×	×		
	Charger wire (TC/AC)	(○)×	▲	▲	▲	▲		
	Screen grid	(○)×	▲	▲	▲	▲		
	Drum separation pawl unit		▲□	▲	▲□	▲		Change the installing position at every 125K. (To prevent against scratches on the drum)
	Waste toner bottle	×						Replace at every 40K. (By the user)
	D. L.		○	○	○	○		
	Charger case (MC/TC/AC)	○	○	○	○	○		
	Charging plate (Saw teeth)	○	▲	▲	▲	▲		
	Drum density sensor		○	○	○	○		
	Drum mark sensor		○	○	○	○		
	Developing section	Developer		×	▲	×		▲
DV seal			×	▲	×	▲		
DSD collar			○	○	○	○		
DV side seal F			×	▲	×	▲		
DV side seal R			×	▲	×	▲		
MG bearing			×	×	×	×		
Toner cartridge							Attach when installing. EX Japan: Supply toner every 25K with 700g. (User replacement)	
Fusing section		Upper heat roller	(○)×	○	▲	○	▲	Clean and remove paper dust.
	Lower heat roller	(○)×	○	▲	○	▲		
	Upper separation pawl	(○)×	▲	▲	▲	▲		
	Lower separation pawl	(○)×	▲□	▲	▲□	▲		
	Thermistor		○	○	○	○		
	Upper heat roller gear		☆	▲	☆	▲		
	Paper guides	○	○	○	○	○		
	Gears		☆	☆	☆	☆		
	Insulation bush		×	×	×	×		
	Cleaning roller		▲	▲	▲	▲		
	Optical section	Mirror/Lens/Reflector/Sensors	○	○	○	○	○	
Table glass/Dust-proof glass/OC		○	○	○	○	○		
RSPF glass		○	○	○	○	○		
Rails			☆	☆	☆	☆		
Drive belt/Drive wire/Pulley			×	×	×	×		
Filters		▲	▲	▲	▲			
Paper feed section	Paper feed rollers (manual/550 cassette)	(○)×	×	×	×	×	[Note 1]	
	500 cassette brake spring	×	☆	☆	☆	☆		
	Torque limiter (500 cassette)	×	×	○☆	×	○☆		
	Torque limiter (manual)	×	×	×	×	×	[Note 1]	
TC	TC paper guide unit	×	×	×	×	×		
Suction	Suction belt	(○)×	○	○	○	○	Newly provided.	
	Separation lamp	×	×	×	×	×		
Transport section	PS follower roller	(○)×	○	○	○	○		
Paper exit reverse section	Transport rollers	(○)×	○	○	○	○		
	Paper exit follower roller (inside)	×	☆	☆	☆	☆		
	Curl correction roller	×	×	▲	×	▲		
	Transport paper guides	(○)×	○	○	○	○		
Drive section	Gears	☆	☆	☆	☆	☆	(Specified position)	
	Belts			×		×		
Copy quality		×	×	×	×	×		
Others	Sensors		×	×	×	×		
RSPF	Paper feed section	Pickup roller	(○)×	×	×	×	×	[Note 2]
		Separation pad	(○)×	×	×	×	×	[Note 2]
		Paper feed roller	(○)×	×	×	×	×	[Note 2]
		Resist roller	(○)×	○	○	○	○	
	Transport section	Transport roller	(○)×	○	○	○	○	
		Exposure section	○	○	○	○	○	
	Paper exit section	Paper exit roller	(○)×	○	○	○	○	Wipe with alcohol for cleaning.
	Others	Sensors		○	○	○	○	Blow air for cleaning. [Note 3]

[Note 1] Replacement reference: Replace according to the counter value of each paper feed port.

- 500-sheet cassette paper feed roller and related parts: 80K or 2 years
- Manual paper feed roller and related parts: 40K or 2 years
- Manual feed torque limiter: 120K or 2 years

[Note 2] Replacement reference: Replace according to the counter value of the document feed unit. : 80K or 2 years

[Note 3] Clean according to the above descriptions or the counter value of the document feed unit: 50K

2. List of disassembly and assembly

Unit	Parts
A. Developing unit	(1) Toner hopper
	(2) Developing side seal (F/R)
B. Drum unit	(1) OPC drum
	(2) Drum separation pawl
	(3) Cleaner blade
	(4) Toner reception seal
	(5) Main charger
	(6) Transfer/separation charger
C. Discharge lamp	(1) Discharge lamp
D. Scanner unit	(1) Table glass
	(2) White reference glass (SPF/RSPF scanning glass)
	(3) CCD unit
	(4) Copy lamp
	(5) Mirror base unit
	(6) Copy lamp unit
	(7) Rails
	(8) Glass section
	(9) Scanner section
E. ICU peripheral	(1) HD unit
	(2) ICU PWB
	(3) SCSI PWB (AR-501/505)
F. Laser unit	(1) Laser scan unit

Unit	Parts
G. Manual paper feed unit	(1) Manual paper feed sensor
	(2) Rollers/torque limiters
H. 500 tray paper unit	(1) Tray unit
	(2) Tray paper feed unit
I. Paper transport unit	(1) Paper transport section
J. Suction unit	(1) Suction unit
K. Fusing unit	(1) Thermistor
	(2) Upper fusing separation pawl
	(3) Lower fusing separation pawl
	(4) Lower heat roller
	(5) Upper heat roller
	(6) Upper heat roller gear
L. Two-tray paper exit unit	(1) Paper exit/transport roller
M. One-tray paper unit	(1) Paper exit roller
	(2) Paper exit/transport roller
N. PCU/AC power/High voltage power/Main motor	(1) PCU/AC power/High voltage power/Main motor
O. Major drive unit	(1) Major drive unit
P. Lift-up unit	(1) Lift-up unit
O. RSPF	(1) Paper feed section
	(2) Transport section
	(3) Paper exit section
	(4) Others

3. Counter clear

Maintenance cycle setting	SIM21-01	
Maintenance counter clear	SIM24-04	At drum replacement
Developing counter clear	SIM24-05	At developer replacement
OPC drum membrane decrease correction counter clear	SIM24-07	At drum replacement
Jam/trouble counter clear	SIM24-01	
Paper feed counter clear	SIM24-02	At maintenance
DF/Scan/Stapler counter clear	SIM24-03	At maintenance
Printer, other counter clear	SIM24-09	

A. Developing unit

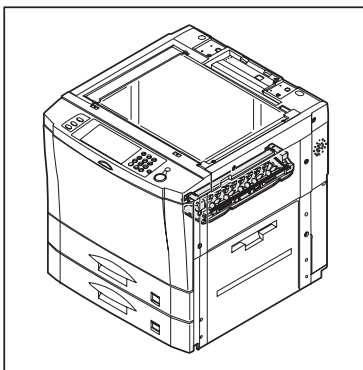

* After replacing developer, execute SIM 24-5 to clear the developer (copy quantity) counter.

(1) Toner hopper

AR-250/280/281/285/286/335/336/405

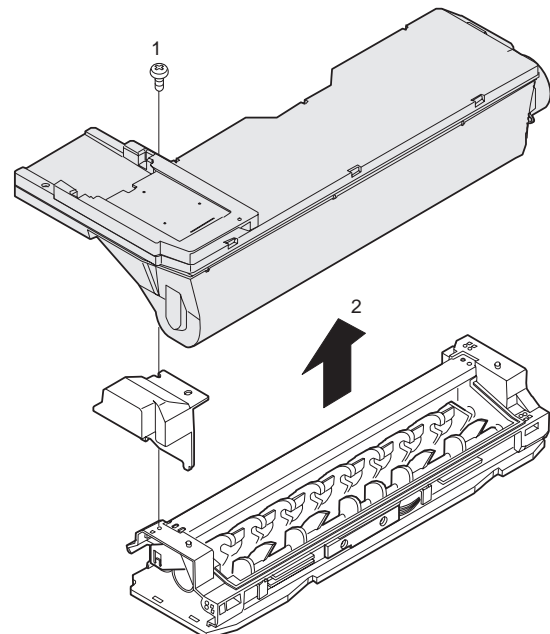

AR-501/505

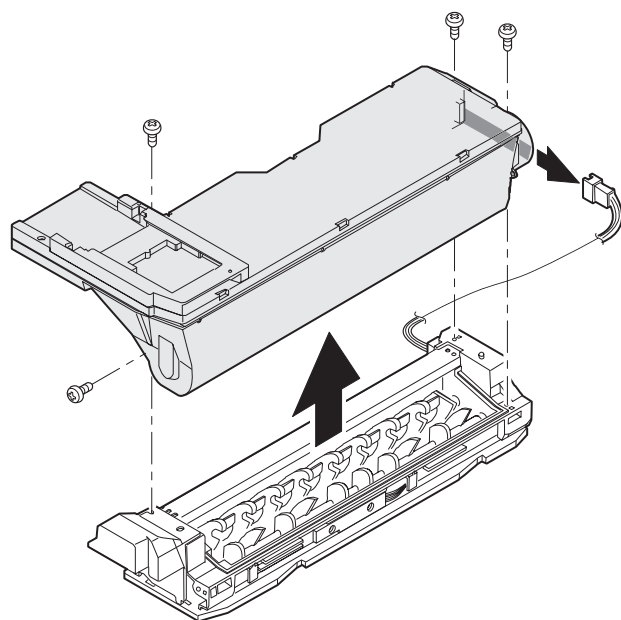

(2) Developing side seal

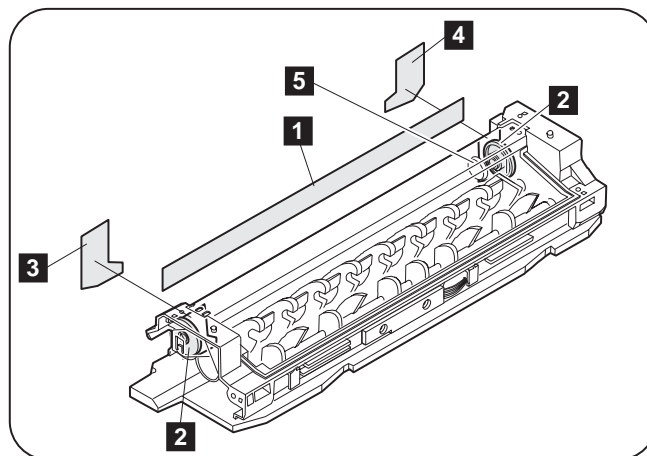
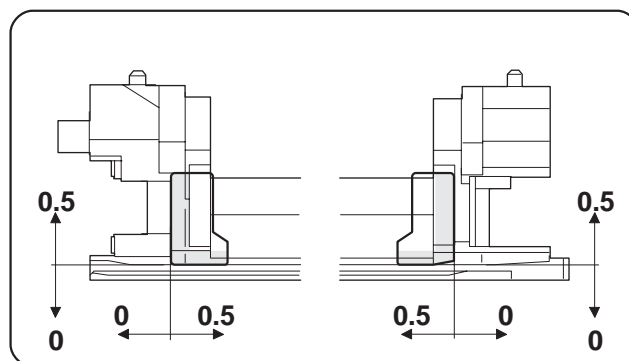

* Attache the developing side seals to the dimensions specified above.

No.	Name	Work item	Cycle			Remark
			AR-250/280/281/ 285/286/335/336	AR-405	AR-501/505	
1	DV seal	Check	80 K	90 K	125K	For attachment position, refer to DISASSEMBLY AND ASSEMBLY.
		Replace	160 K	180 K	250K	For attachment position, refer to DISASSEMBLY AND ASSEMBLY.
2	DSD collar	Clean	80 K	90 K	125K	
3	DV side seal F	Check	80 K	90 K	125K	
		Replace	160 K	180 K	250K	For attachment position, refer to DISASSEMBLY AND ASSEMBLY.
4	DV side seal R	Check	80 K	90 K	125K	
		Replace	160 K	180 K	250K	For attachment position, refer to DISASSEMBLY AND ASSEMBLY.
5	MG bearing	Check	—	—	125K	

B. Drum unit

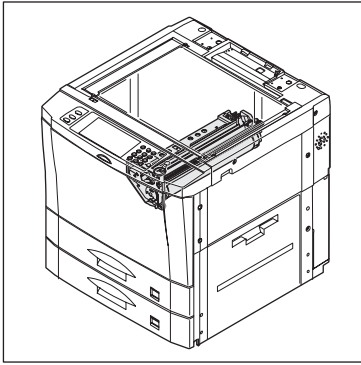

AR-280/285/335

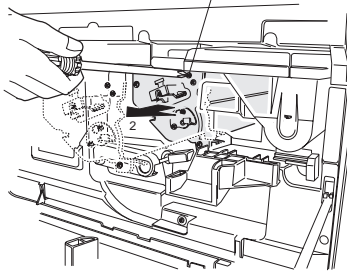
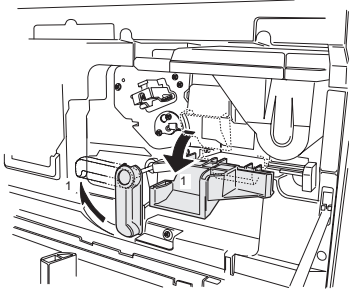

AR-250/281/286/336/405/501/505

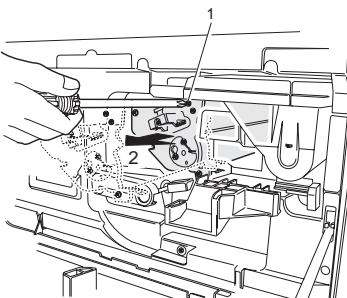
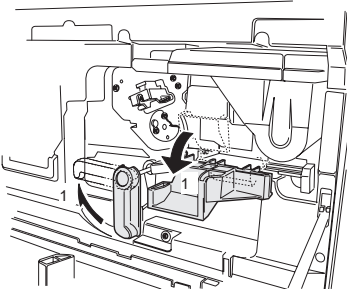

**(1) OPC drum
AR-280/285/335**

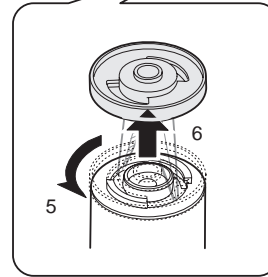
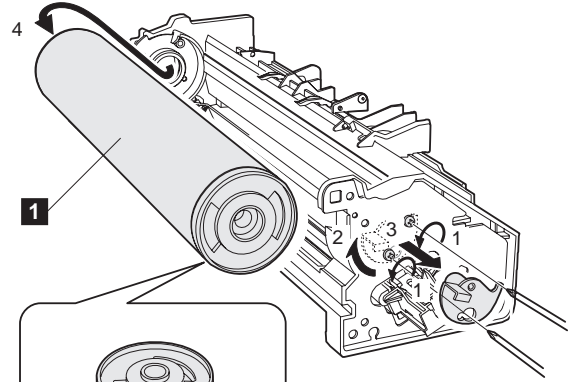

AR-250/281/286/336/405/501/505

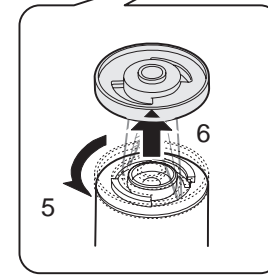
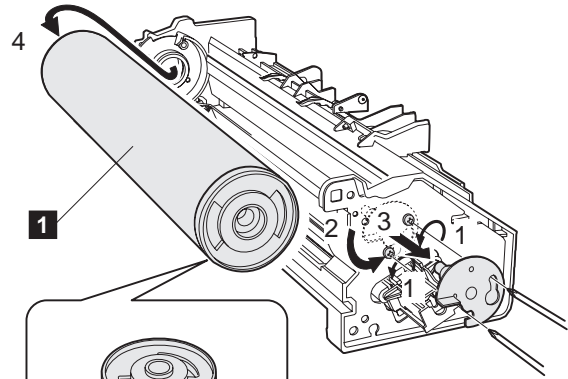

No.	Name	Work item	Cycle			Remark
			AR-250/280/281/ 285/286/335/336	AR-405	AR-501/505	
1	Drum	Check	80 K	90 K	125K	Installed when shipping (Alldestinations)
		Replace	160 K	180 K	250K	Execute SIM 24-7 after replacement.

* After replacing the OPC drum, execute SIM 24-7 to clear the counter.

* When installing the OPC drum, apply starting powder(UKOG-0088CSZZ).

(2) Drum separation pawl

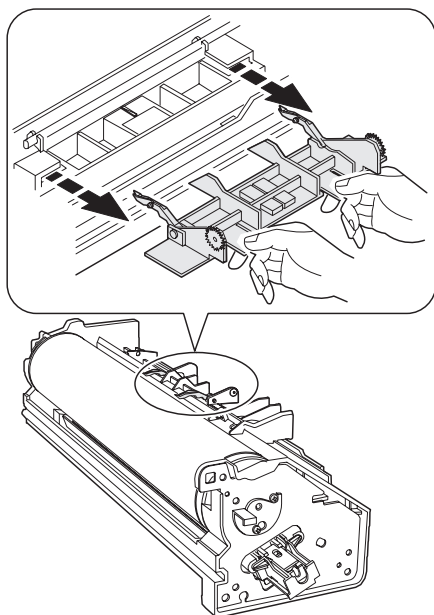

(The illustrations are the same as those of the AR-335.)

* Be careful to clean the pawl lead edge (the contact section with the drum) and keep it from foreign materials.

(3) Cleaner blade

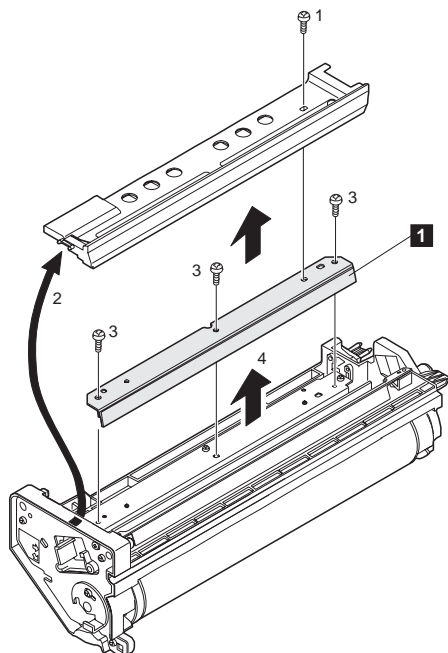

(The illustrations are the same as those of the AR-335.)

* Do not touch the blade and the rubber section.

* When installing, apply starting powder (UKOG-0088CSZZ).

(4) Toner reception seal

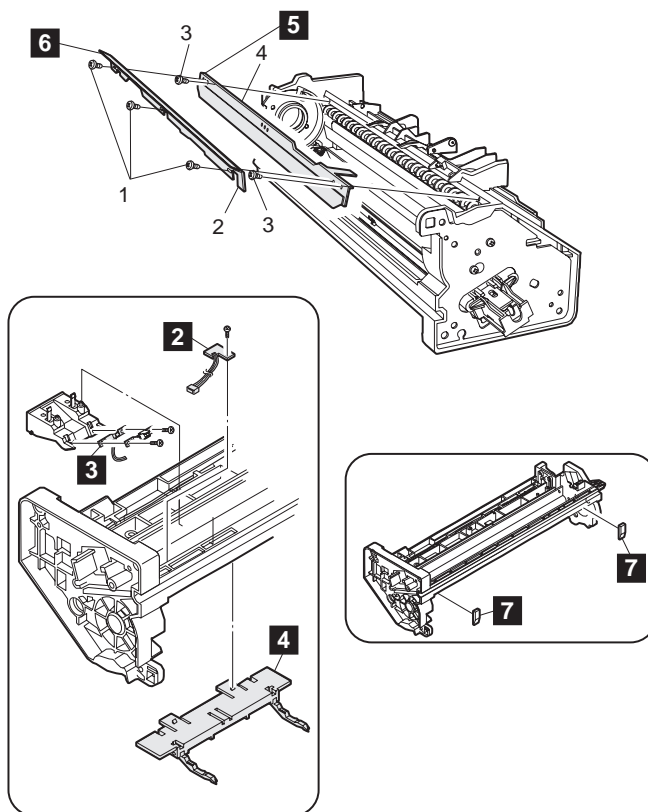

* Do not touch the seat section.

No.	Name	Work item	Cycle			Remark
			AR-250/280/281/ 285/286/335/336	AR-405	AR-501/ 505	
1	Cleaner blade	Replace	80 K	90 K	125K	
2	Drum mark sensor	Clean	80 K	90 K	125K	After cleaning, perform SIM 44-2.
3	Drum density sensor	Clean	80 K	90 K	125K	After cleaning, perform SIM 44-2.
4	Drum separation pawl unit	Replace	80 K	90 K	125K	Change the installing position at every 80 K
5	Toner reception seal	Replace	80 K	90 K	125K	
6	Toner reception auxiliary blade	Clean	80 K	90 K	125K	
7	Cleaner side seal F/R	Check	—	90K	125K	

(5) Main charger

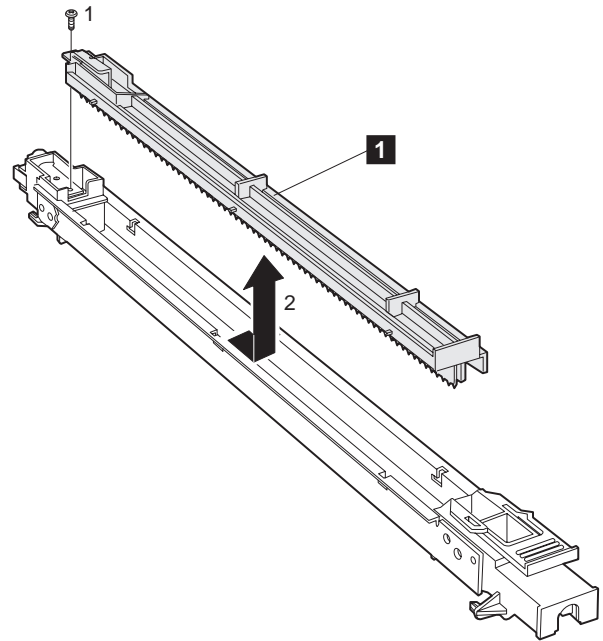
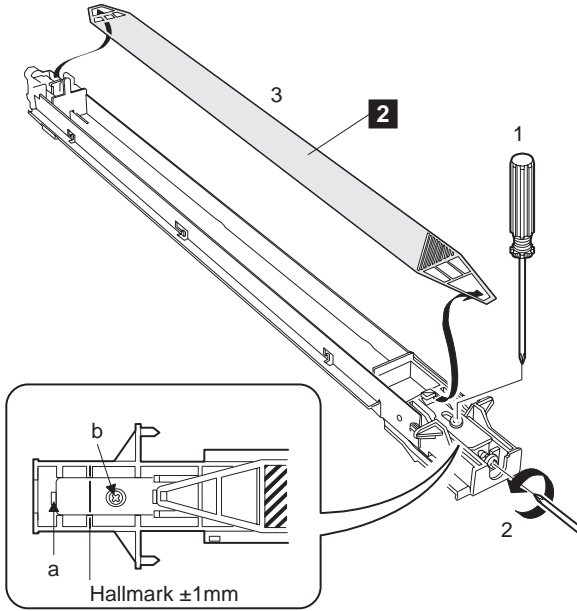
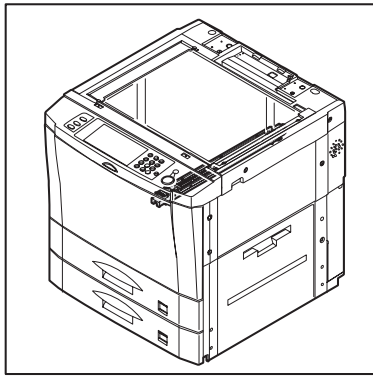

* Adjust the screen grid tension so that the marking on the screen holder and the marking on the MC holder come on a same line. Tighten screw a, then tighten screw b.

No.	Name	Work item	Cycle			Remark
			AR-250/280/281/ 285/286/335/336	AR-405	AR-501/505	
1	Charging plate (Saw tooth)	Replace	80 K	90 K	125K	
2	Screen grid	Replace	80 K	90 K	125K	

(6) Transfer/separation charger

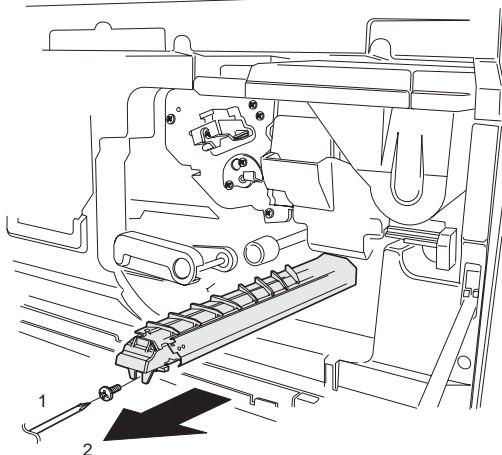
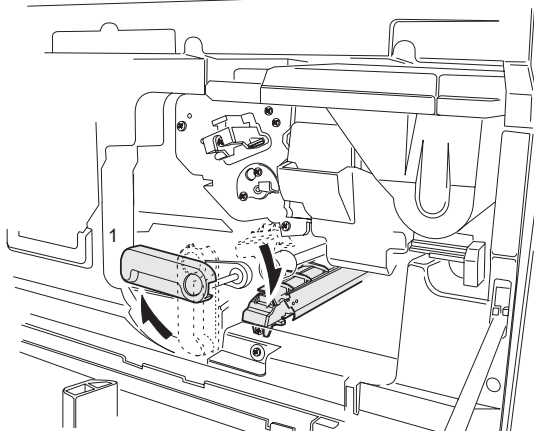
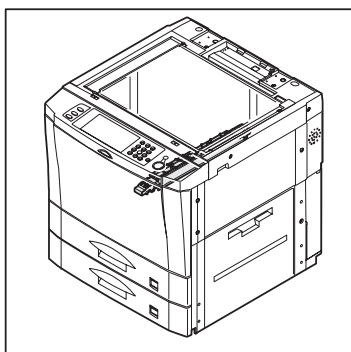

(The illustrations are the same as those of the AR-335.)

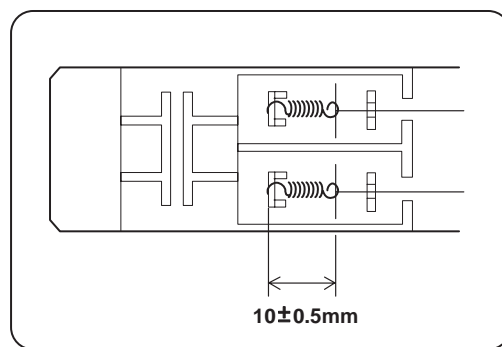
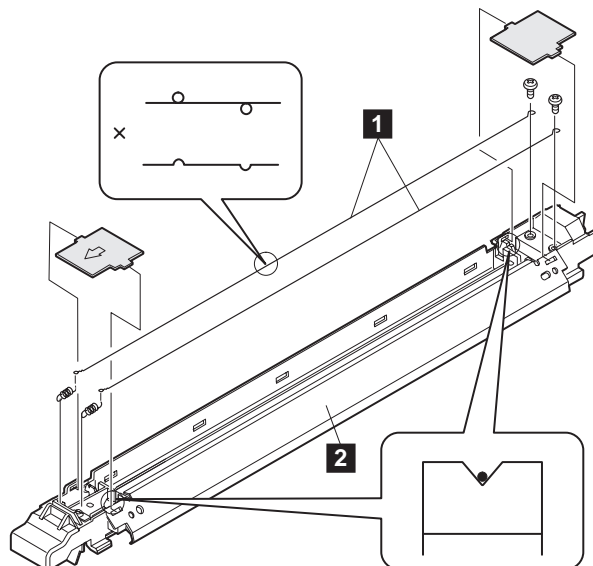
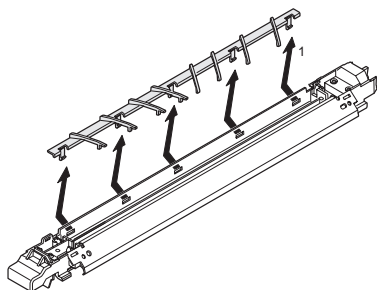

- * When replacing the charger wire:
- Be careful not to twist or bend the wire.
 - Stretch the wire so that the tension spring length is as shown above.
 - Securely put the charger wire in the groove.

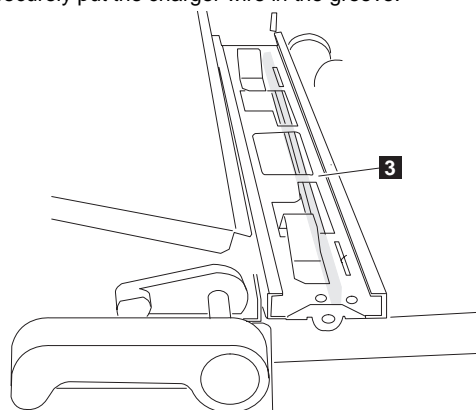

No.	Name	Work item	Cycle			Remark
			AR-250/280/281/ 285/286/335/336	AR-405	AR-501/ 505	
1	Charger wire (TC/AC)	Replace	80 K	90 K	125K	
2	Charger case (MC/TC/AC)	Clean	80 K	90 K	125K	
3	Separation lamp	Clean	—	—	125K	

C. Discharge lamp

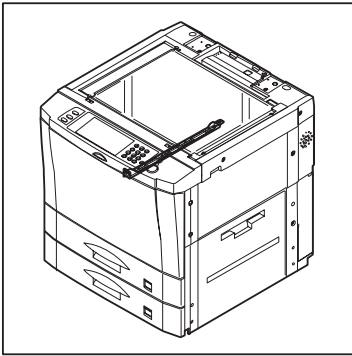

(1) Discharge lamp

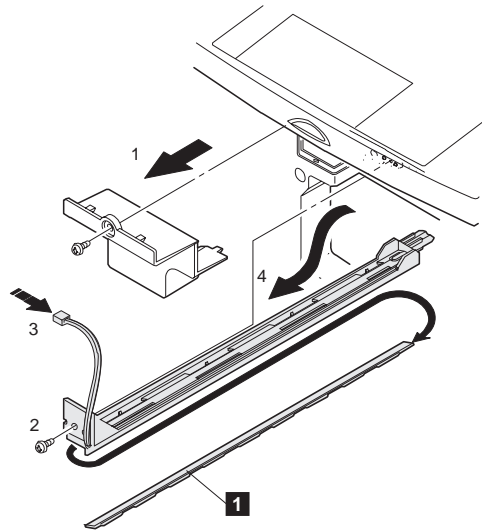

No.	Name	Work item	Cycle			Remark
			AR-250/280/281/ 285/286/335/336	AR-405	AR-501/ 505	
1	Discharge lamp	Clean	80 K	90 K	125K	

D. Scanner unit (Optical system)

(1) Table glass

AR-250/280/281/285/286/335/336/405

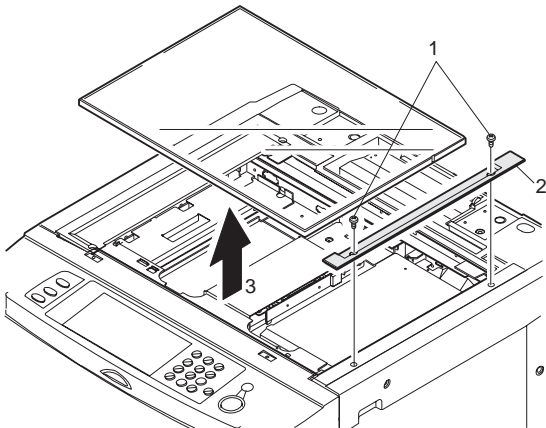

AR-501/505

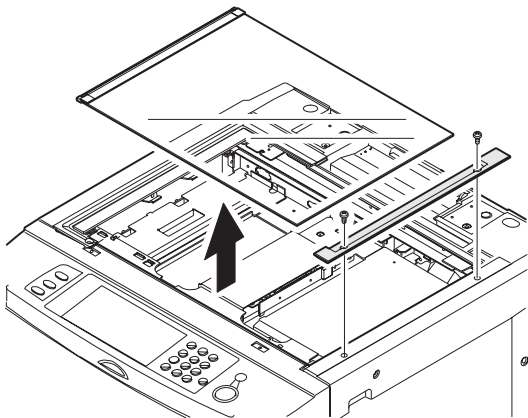

(2) White reference glass (SPF/RSPF scan glass)

AR-250/280/281/285/286/335/336/405

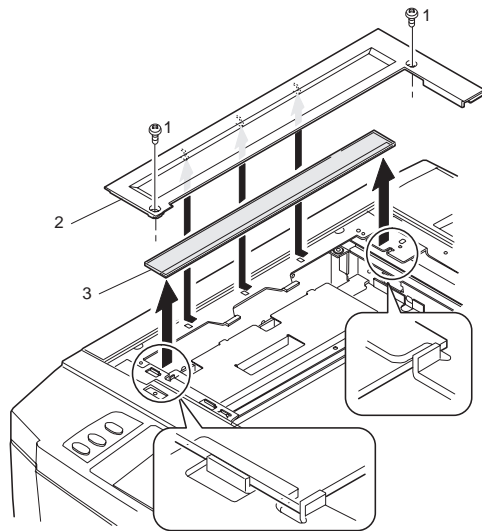

AR-501/505

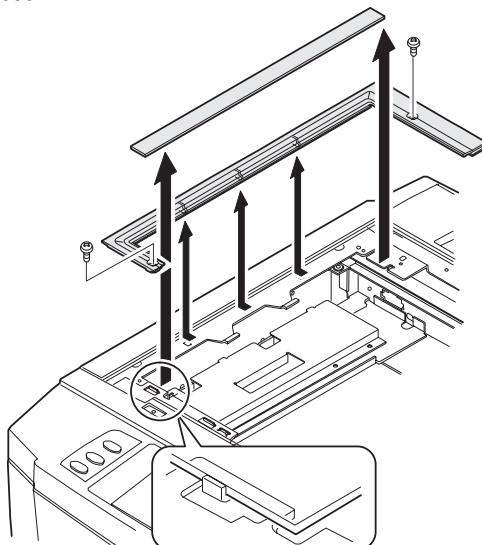

* Table glass installing direction

- Install the table glass so that the white marking on the glass is in the paper feed direction rear side.

- * The shape of the glass holder differs depending on the model.

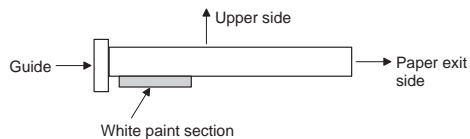

- * Attach the glass along the guide so that the white paint section of the white reference glass faces downward as shown above.
- * When handling the white reference glass, be careful not to scratch the white paint section and keep it from dirt or dust.

(3) CCD unit

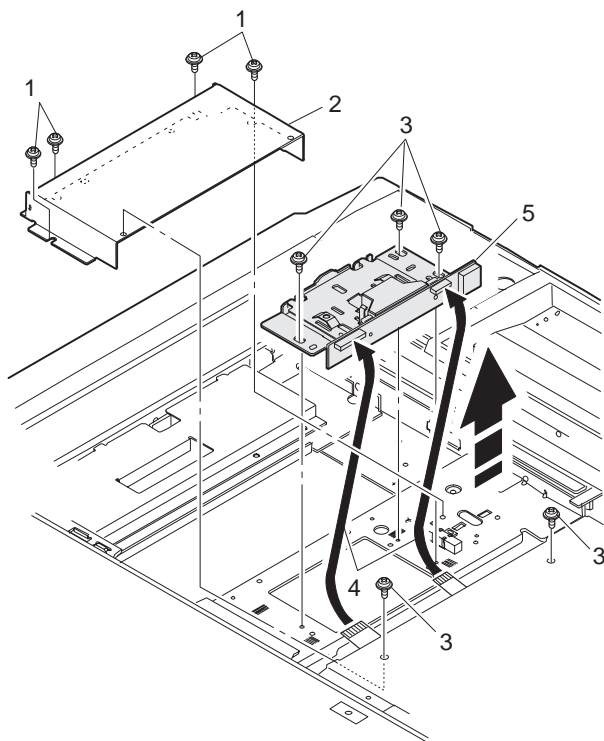

- * Never loosen the screws other than those which are shown in the above figure. If loosened, the adjustment cannot be made in the market.
- * When removing the CCD unit, mark the installing position.
- * When installing again, perform the main scanning direction magnification ratio adjustment (CCD unit installing position adjustment) described above.

(4) Copy lamp

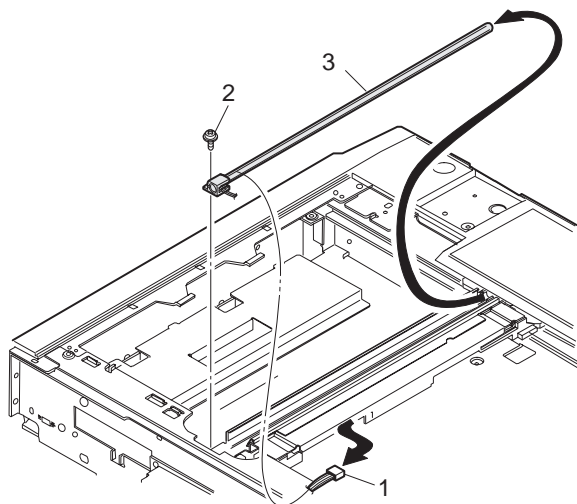

- * Note for assembling the copy lamp unit

Shift the copy lamp unit to the paper exit side, and fix it with the harness guide so that the distance from the lower frame is about 24 ± 2 mm, (25 ~ 30mm) with the copy lamp harness extended.

If the copy lamp harness is loosely fixed, the copy lamp unit may jump up when reading, resulting in abnormal reading.

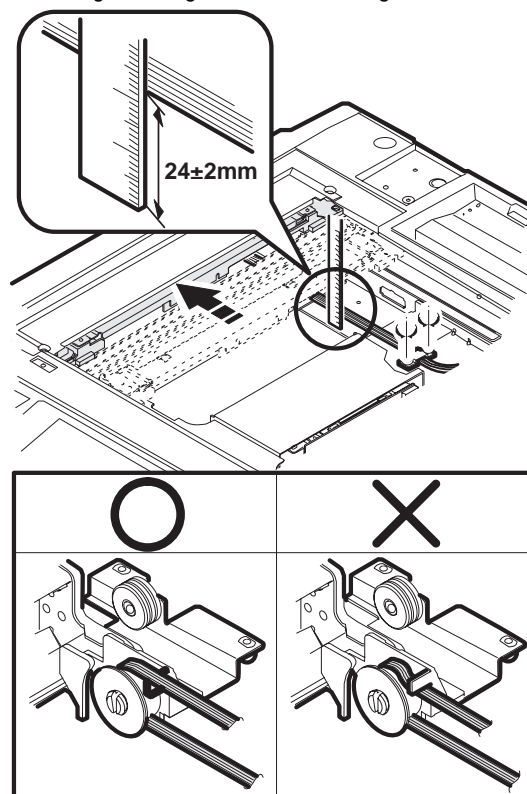

(5) Mirror base unit

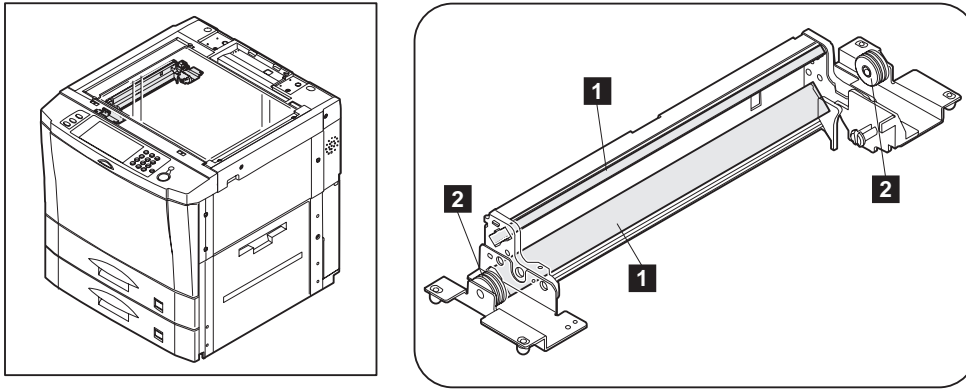

No.	Name	Work item	Cycle			Remark
			AR-250/280/281/ 285/286/335/336	AR-405	AR-501/505	
1	Mirror	Clean	80 K	90 K	125K	
2	Pulley	Check	80 K	90 K	125K	

(6) Copy lamp unit

AR-280/285/335

AR-250/281/286/336/405/501/505

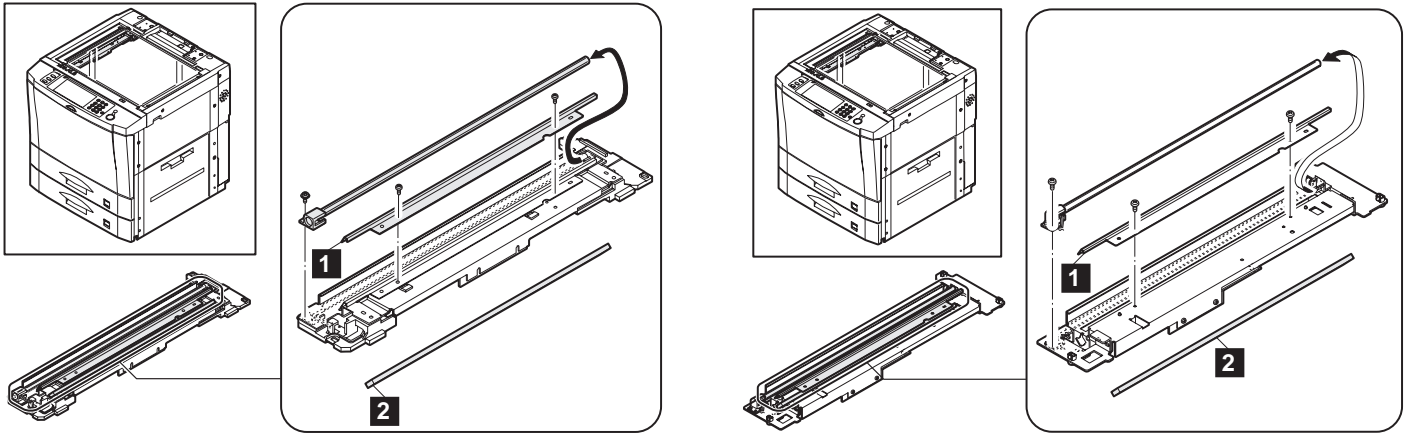

No.	Name	Work item	Cycle			Remark
			AR-250/280/281/ 285/286/335/336	AR-405	AR-501/505	
1	Reflector	Clean	80 K	90 K	125K	
2	Mirror	Clean	80 K	90 K	125K	

(7) Rails

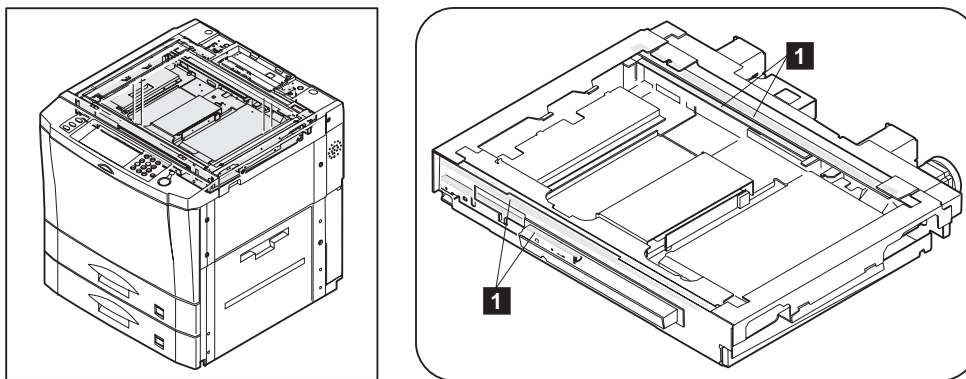

No.	Name	Work item	Cycle			Remark
			AR-250/280/281/ 285/286/335/336	AR-405	AR-501/505	
1	Rails	Lubricate	80 K	90 K	125K	

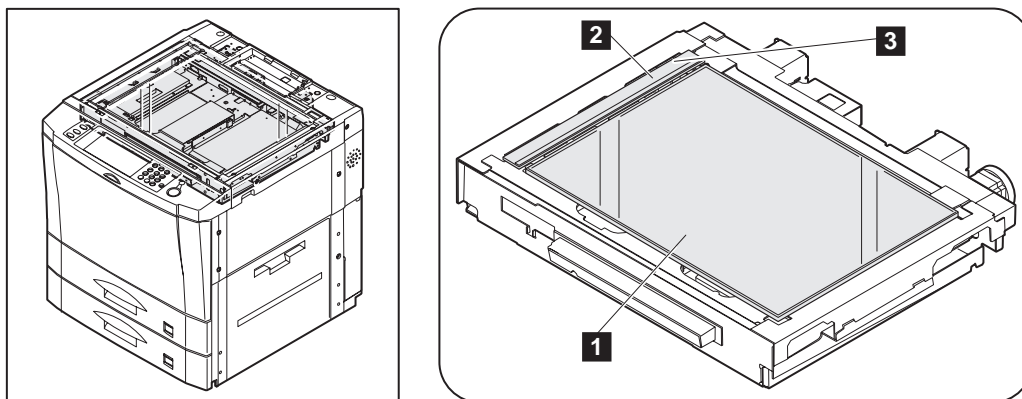
(8) Glass section

No.	Name	Work item	Cycle			Remark
			AR-250/280/281/ 285/286/335/336	AR-405	AR-501/505	
1	Table glass	Clean	80 K	90 K	125K	
2	White reference glass (OC)	Clean	80 K	90 K	125K	
3	RSPF glass	Clean	—	—	125K	

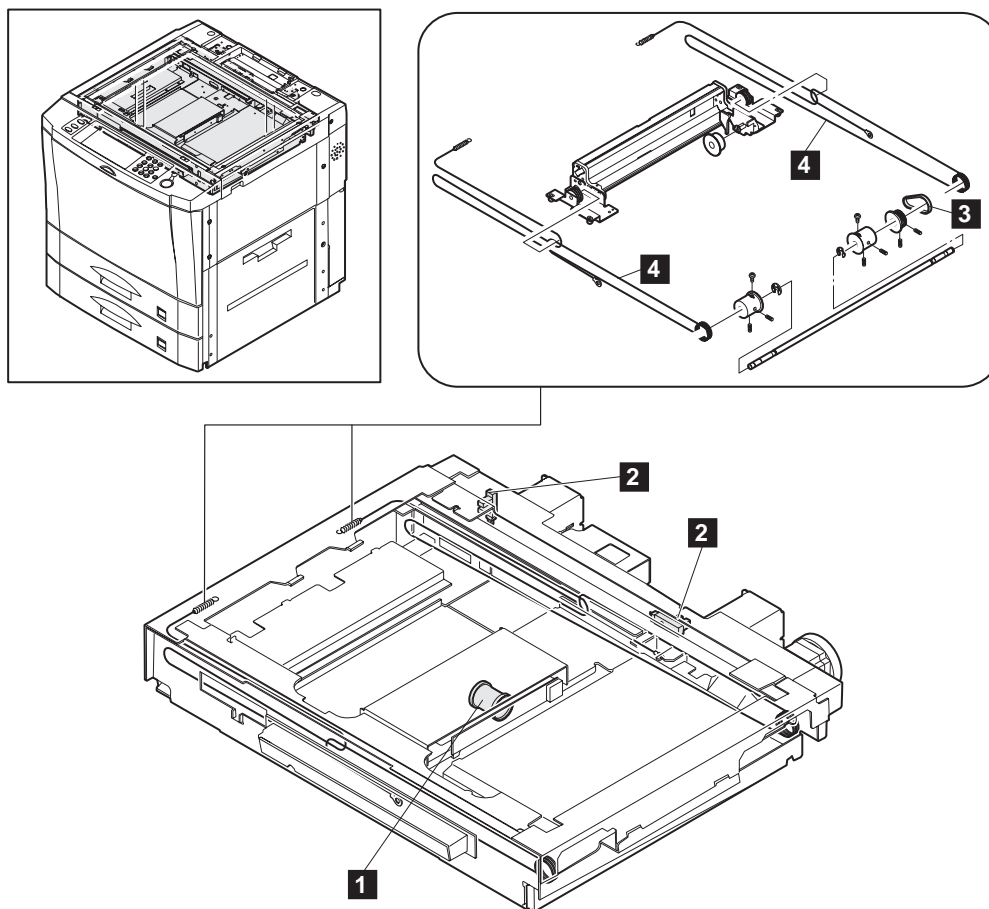
(9) Scanner section

No.	Name	Work item	Cycle			Remark
			AR-250/280/281/ 285/286/335/336	AR-405	AR-501/505	
1	Lens	Clean	80 K	90 K	125K	Do not use screws.
2	Sensors	Clean	80 K	90 K	125K	
3	Drive belt	Check	80 K	90 K	125K	
4	Drive wire	Check	80 K	90 K	125K	

E. ICU peripheral

AR-250/280/281/285/286/335/336/405

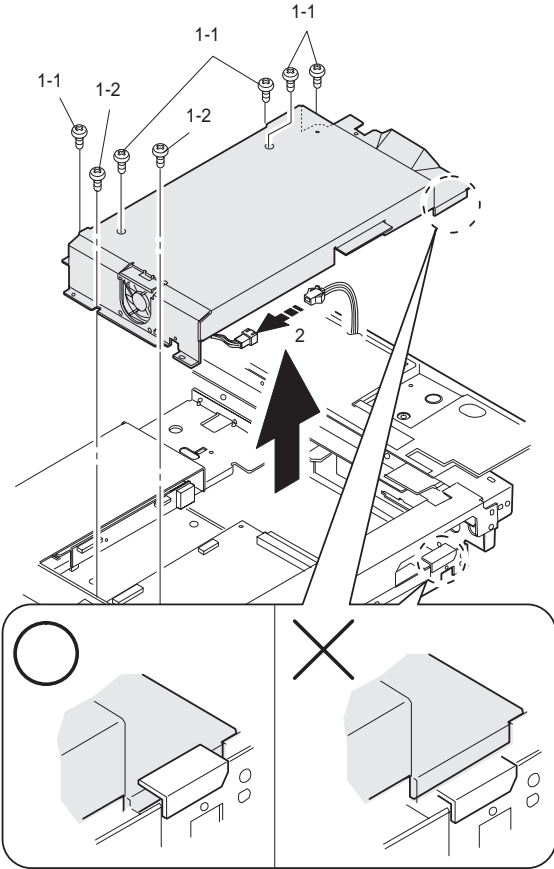

AR-501/505

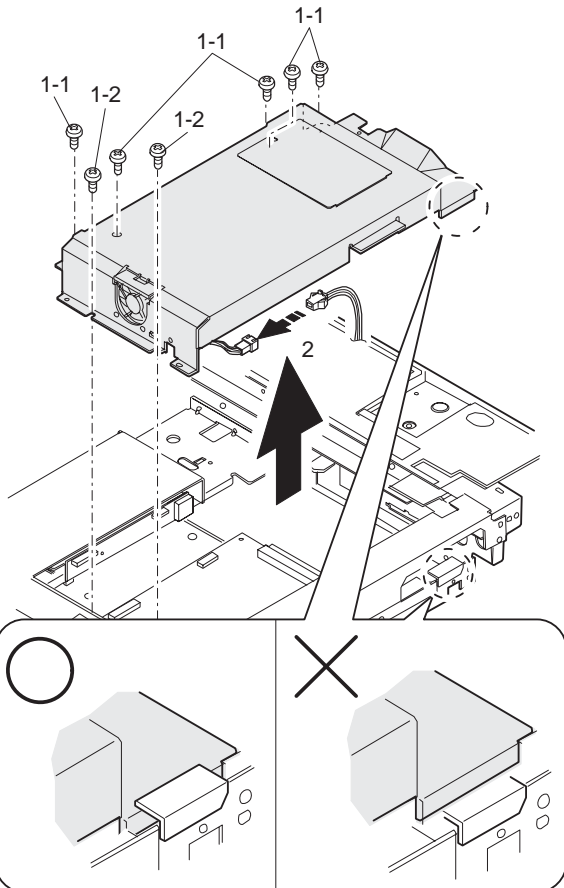

* Screw of 1)-1 and that of 1)-2 are different from each other.

(1) HD unit

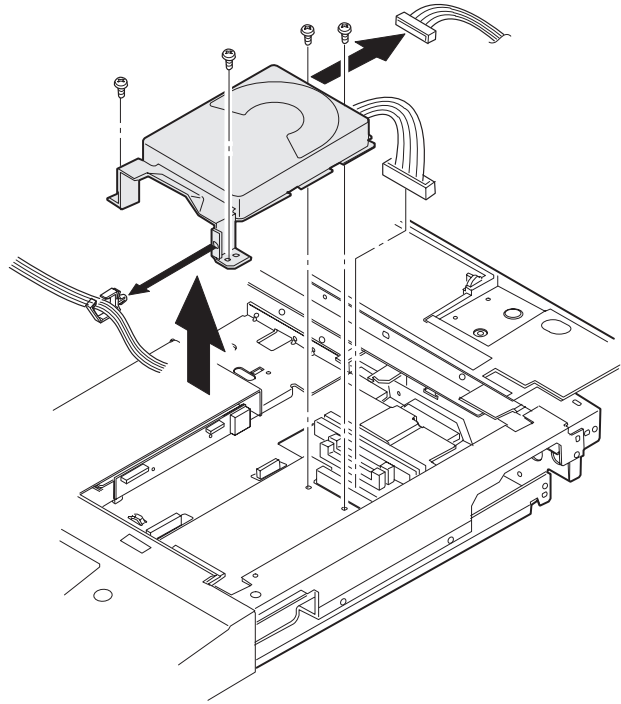

(2) ICU PWB

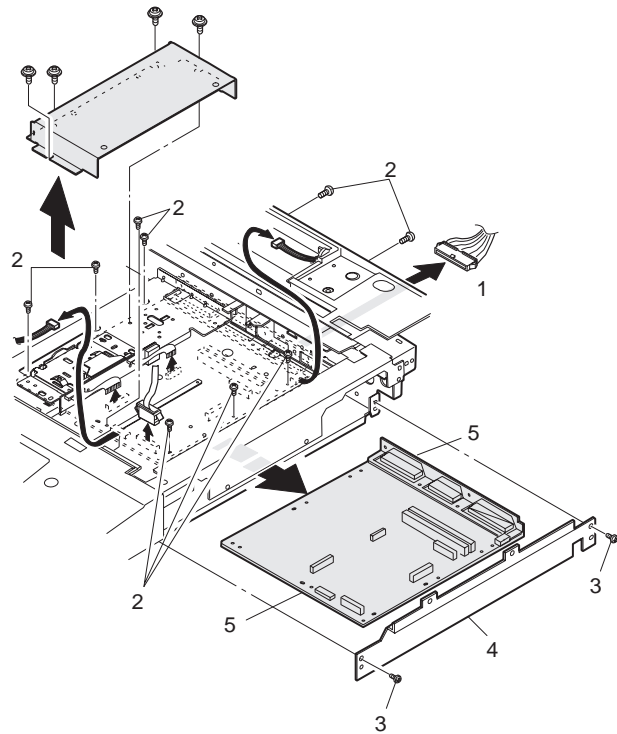

(3) SCSI PWB (AR-501/505)

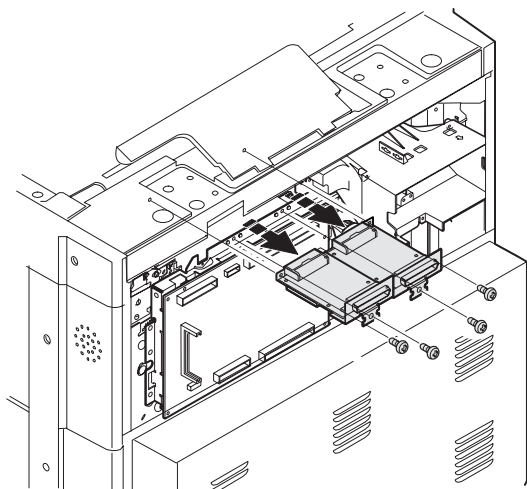

(1) Laser scanner unit

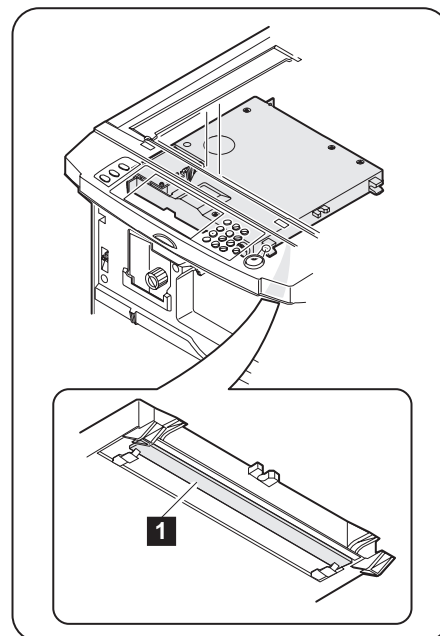
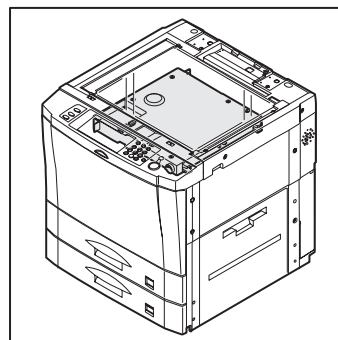

F. Laser unit

* Never let the laser beam directly come into your eyes, or you may go blind.

AR-250/280/281/285/335/336

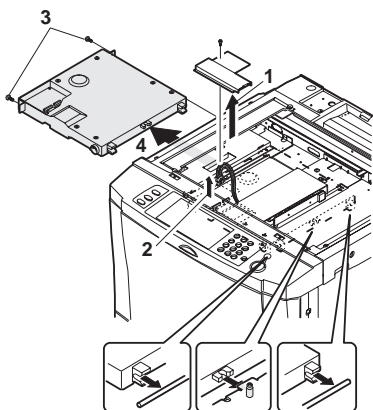

AR-405/501/505

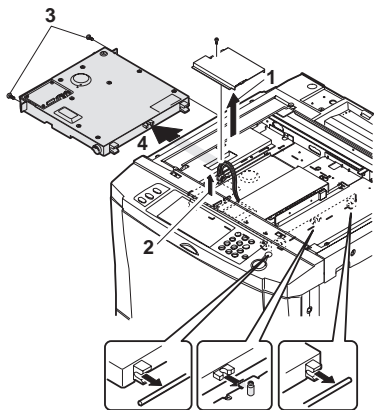

- * When installing the laser unit, check that the three points a, b, and c are securely in positions. If not, printing errors may occur.
- * Do not open the LSU cover (top plate).

No.	Name	Work item	Cycle			Remark
			AR-250/280/281/ 285/286/335/336	AR-405	AR-501/505	
1	Dust-proof glass	Clean	80 K	90 K	125K	

G. Manual paper feed tray unit

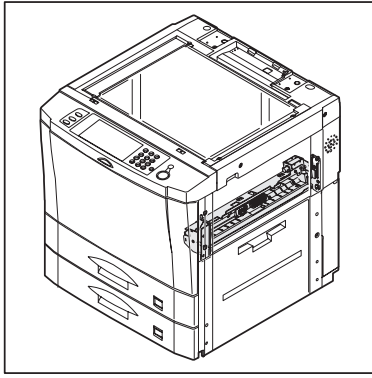

(2) Rollers/torque limiters

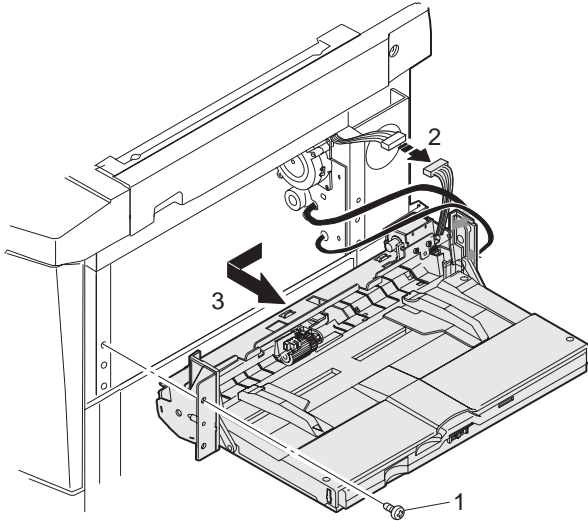
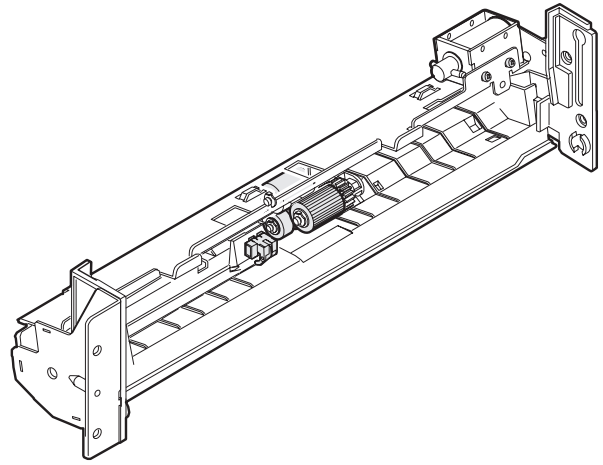

(1) Manual feed paper sensor

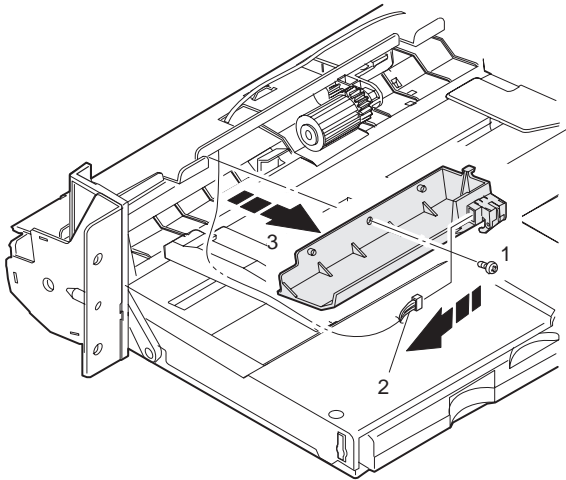
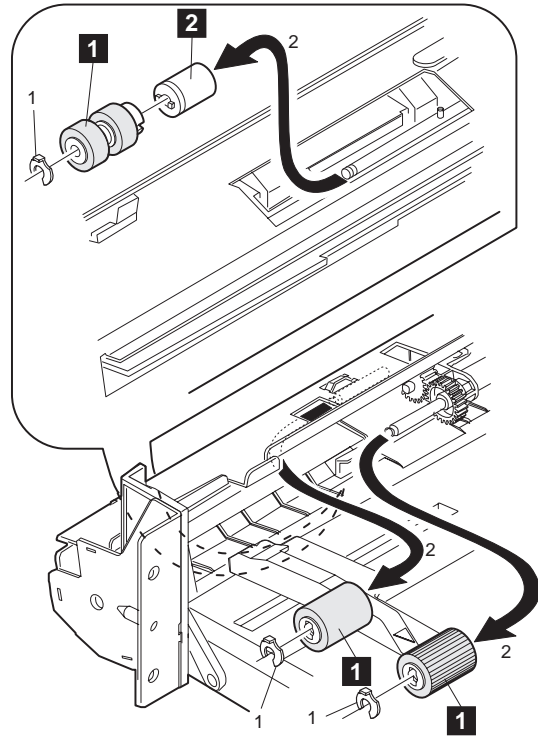

No.	Name	Work item	Cycle			Remark
			AR-250/280/281/ 285/286/335/336	AR-405	AR-501/505	
1	Rollers	Clean	80 K	90 K	125K	
		Check	80 K	90 K	125K	
		Replace	40 K or 2 years	40 K or 2 years	40K or 2 years	Reference: manual paper feed port counter
2	Torque limiter	Check	80 K	90 K	125K	
		Replace	120 K or 2 years	120 K or 2 years	120K or 2 years	Reference: manual paper feed port counter

H. 500 tray paper unit

(1) Tray unit

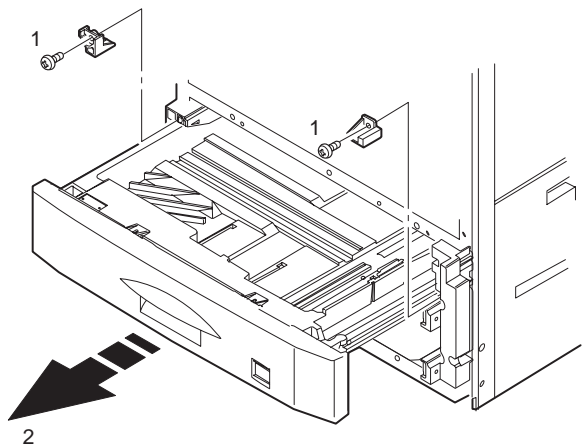
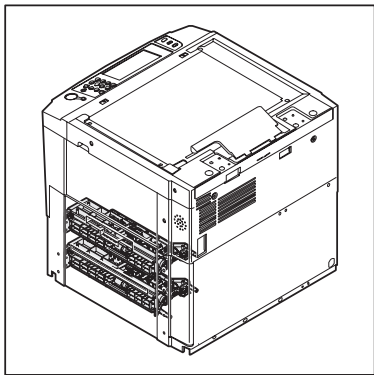

(2) Tray paper feed unit

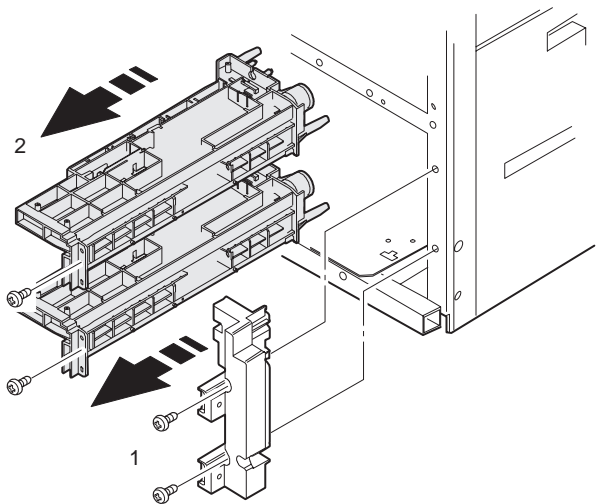

AR-250/280/281/285/286/335/336/405

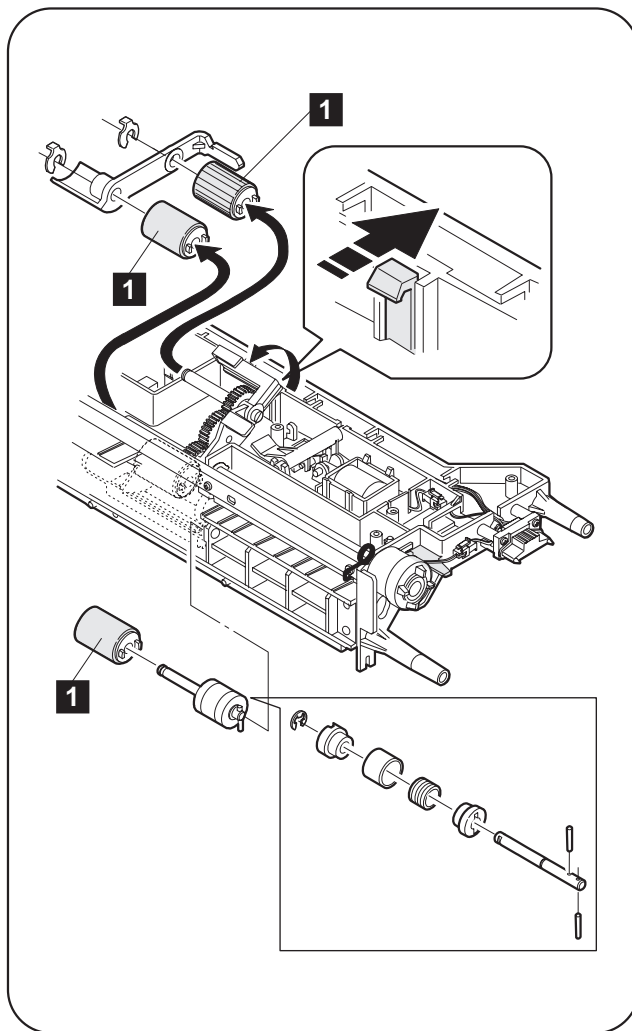

AR-501/505

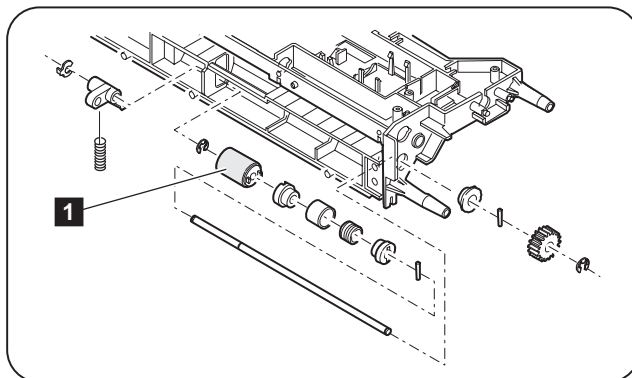

No.	Name	Work item	Cycle			Remark
			AR-250/280/281/ 285/286/335/336	AR-405	AR-501/505	
1	Rollers	Clean	80 K	90 K	125K	Reference: paper fed port counter
		Check	80 K	90 K	125K	
		Replace	80 K or 2 years	80 K or 2 years	80K or 2 years	

I. Paper transport section

(1) Paper transport section

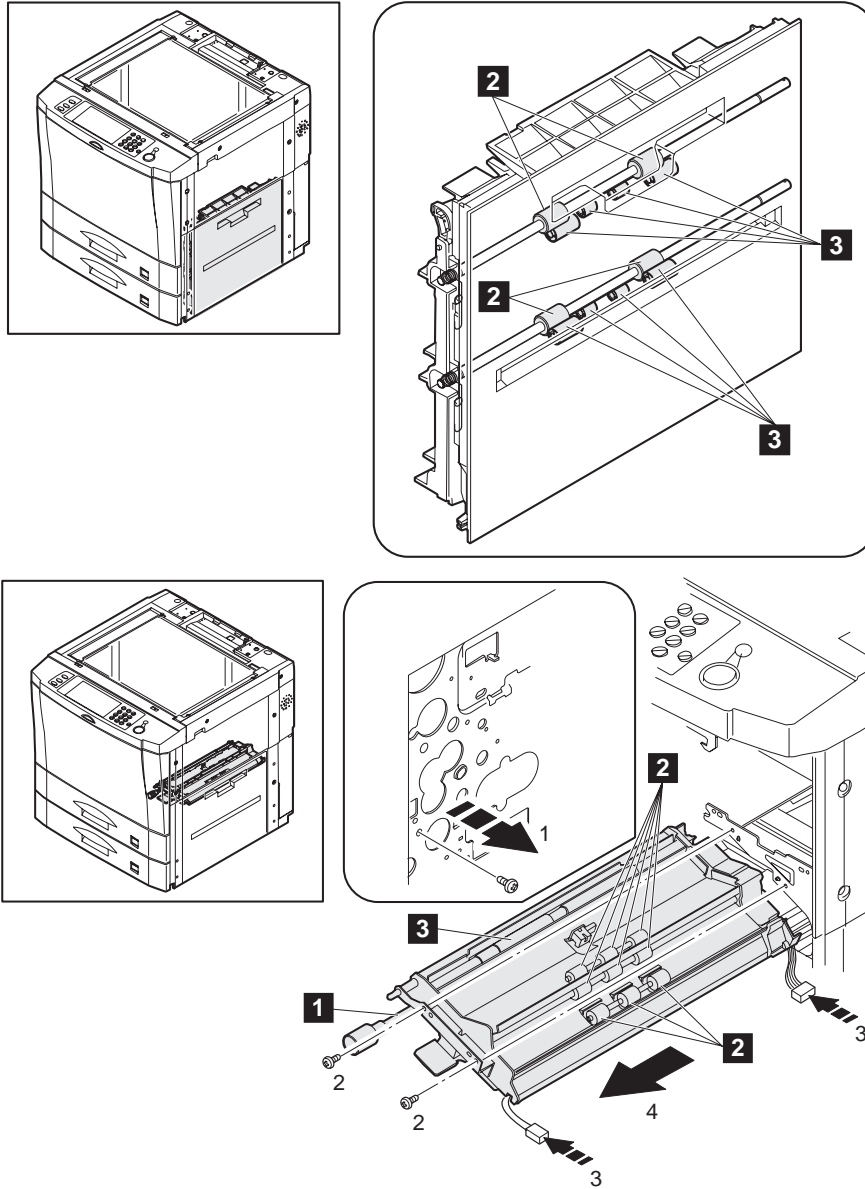

No.	Name	Work item	Cycle			Remark
			AR-250/280/281/ 285/286/335/336	AR-405	AR-501/505	
1	Resist roller	Clean	80 K	90 K	125 K	
2	Transport rollers	Clean	80 K	90 K	125 K	
3	Rollers	Clean	80 K	90 K	125 K	

J. Suction unit

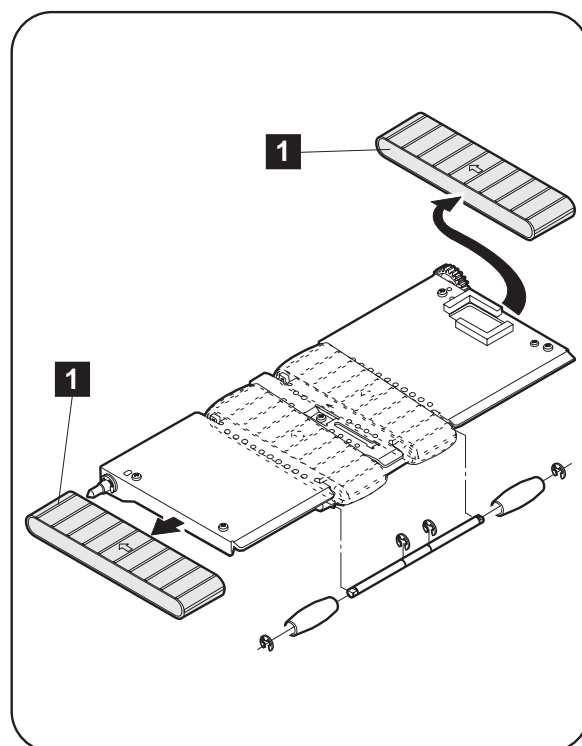
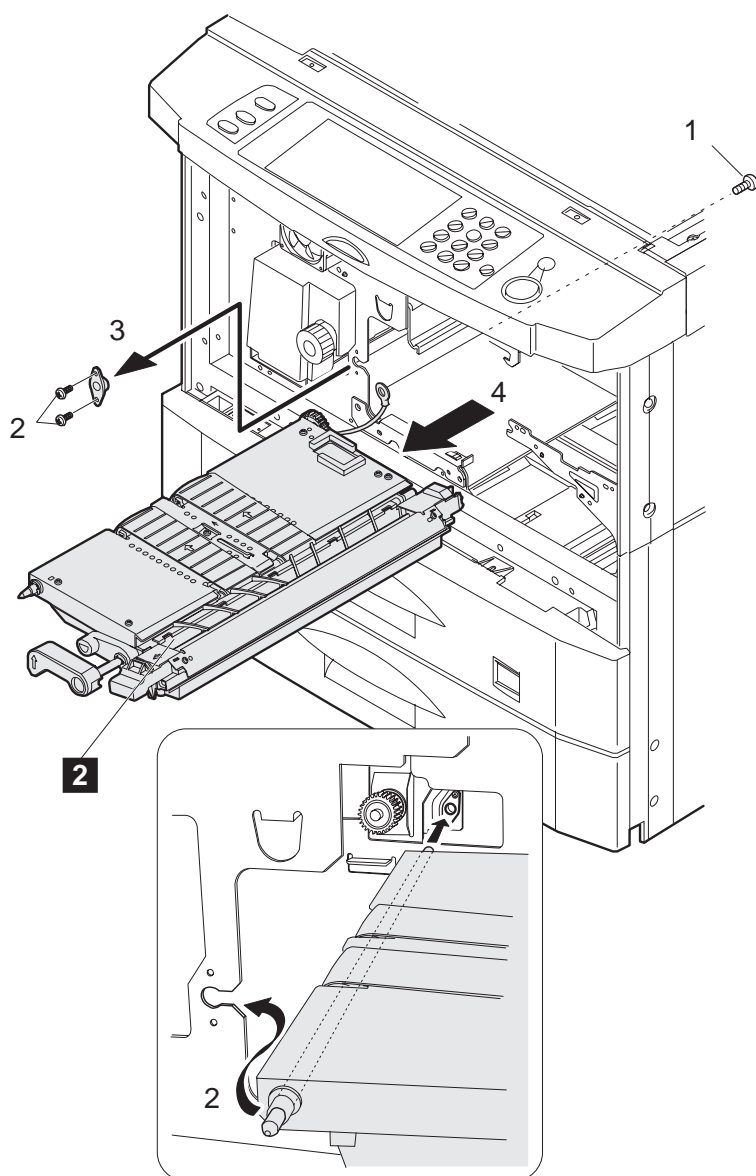
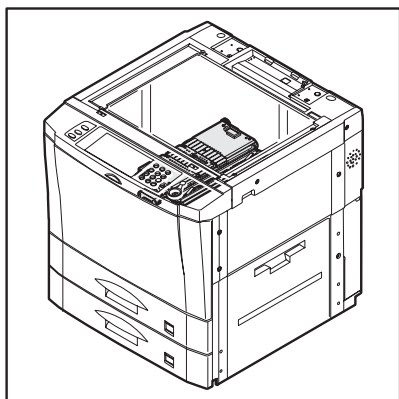

* When assembling, be sure to connect the earth line.

* When installing the belt, install so that the arrow mark on the belt faces in the paper feed direction.

No.	Name	Work item	Cycle			Remark
			AR-250/280/281/ 285/286/335/336	AR-405	AR-501/505	
1	Suction belt	Clean	80 K	90 K	125K	
2	Separation lamp	Check	—	—	125K	

K. Fusing unit

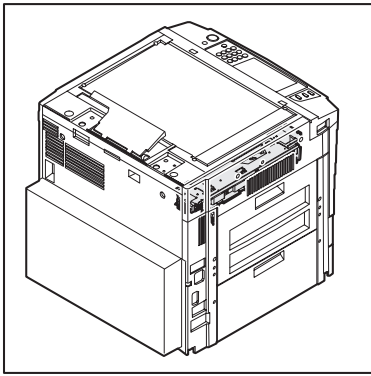

* The fusing unit is heated to a very high temperature. When handling it, be careful of burning.

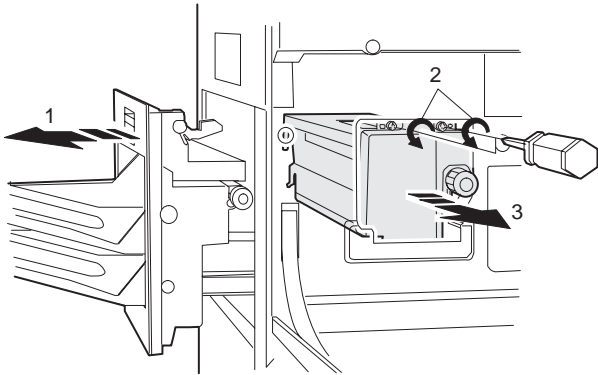

(1) Thermistor

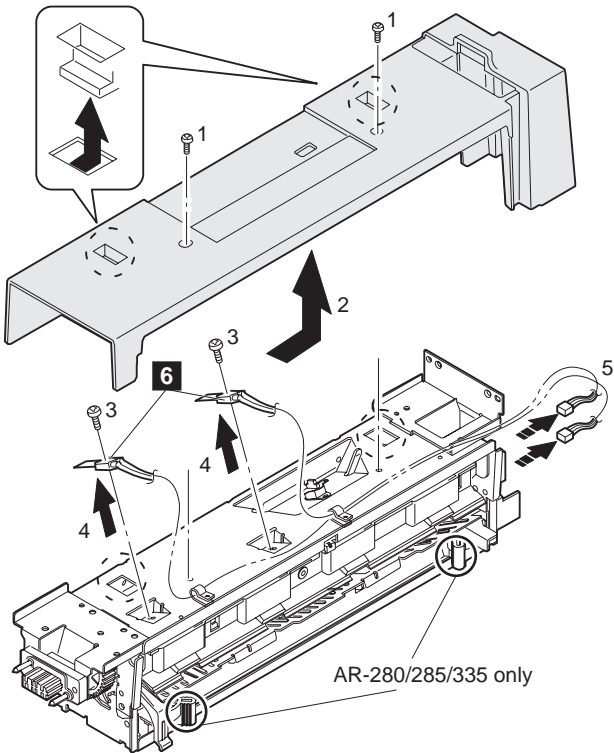

(2) Upper fusing separation pawl

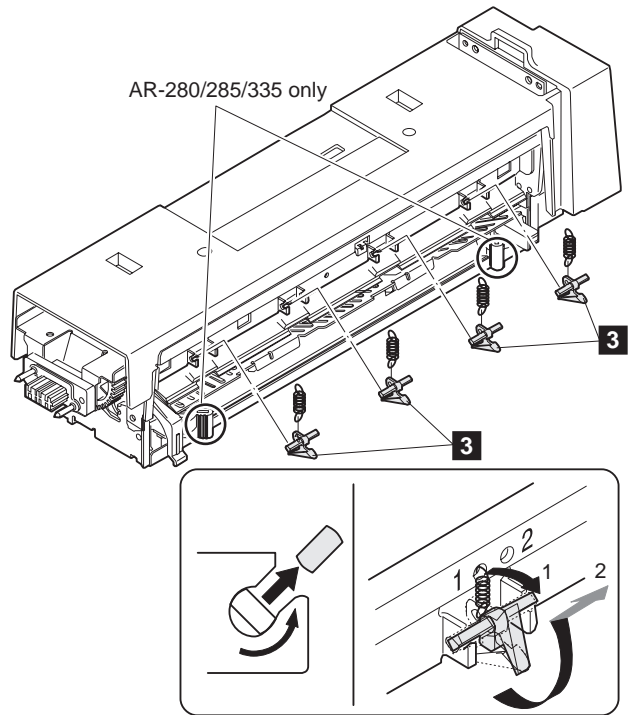
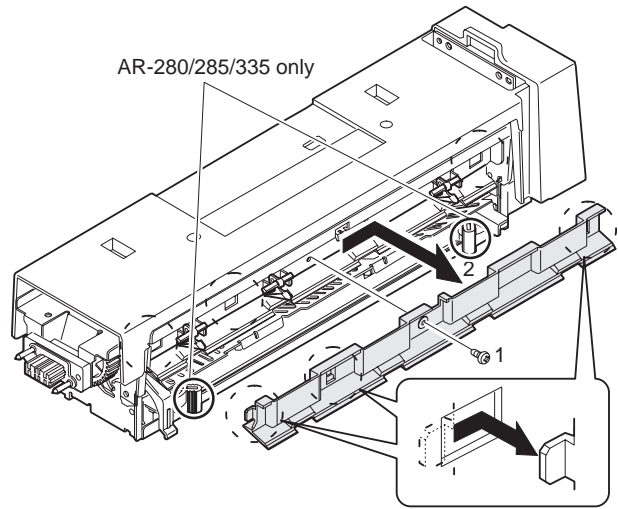

* Put the spring on the side of "1".

(3) Lower fusing separation pawl

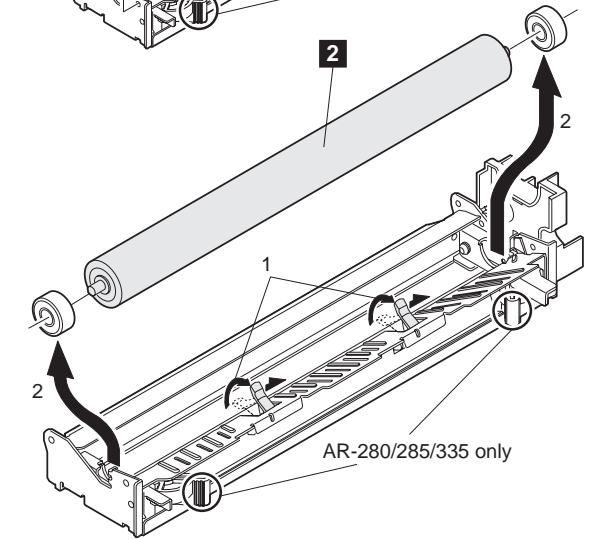
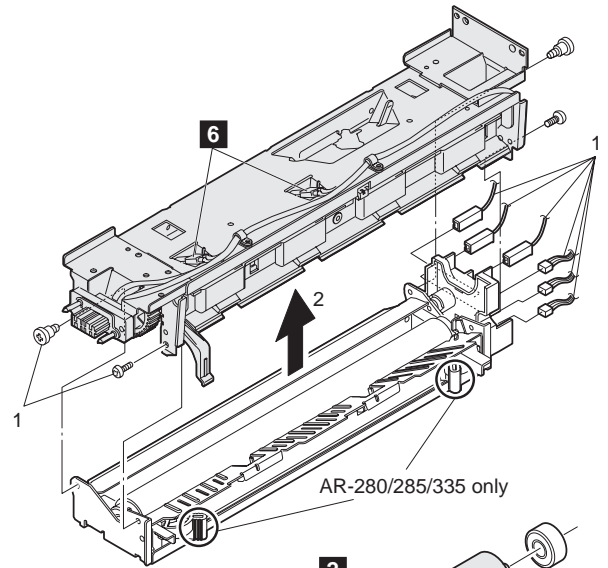
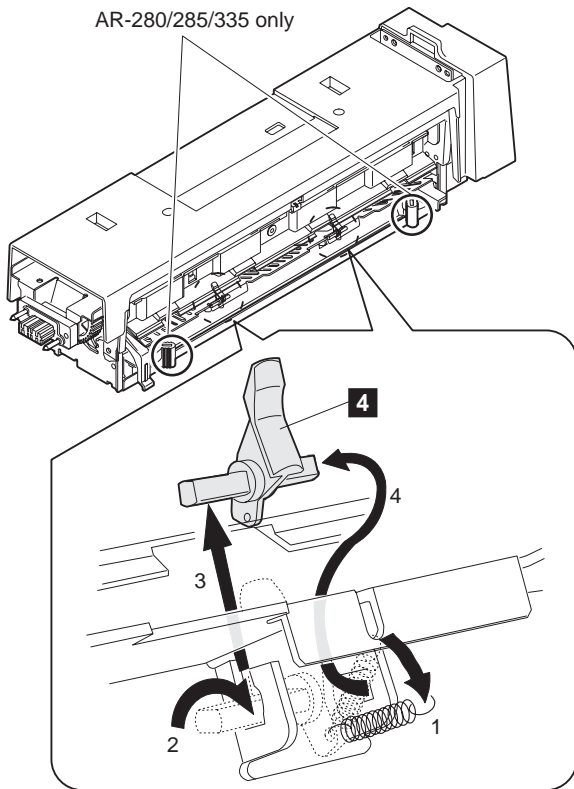

(4) Lower heat roller

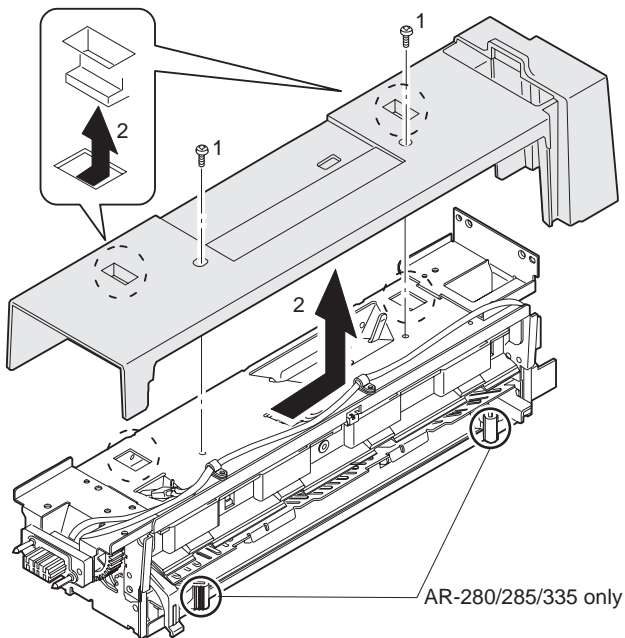

(5) Upper heat roller

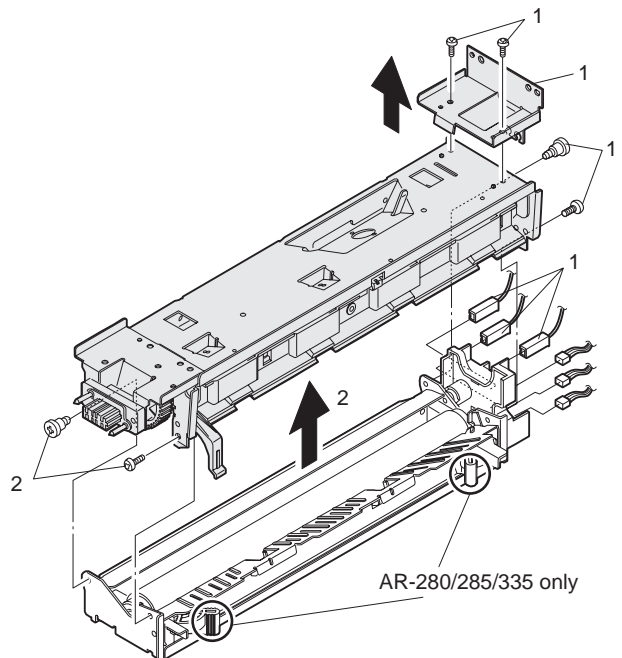

(6) Upper heat roller gear

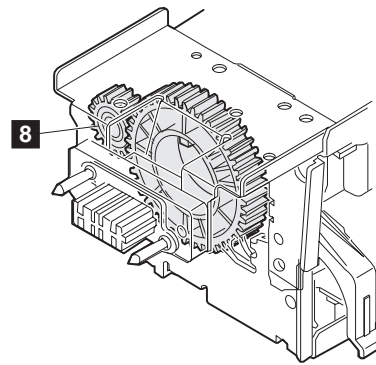
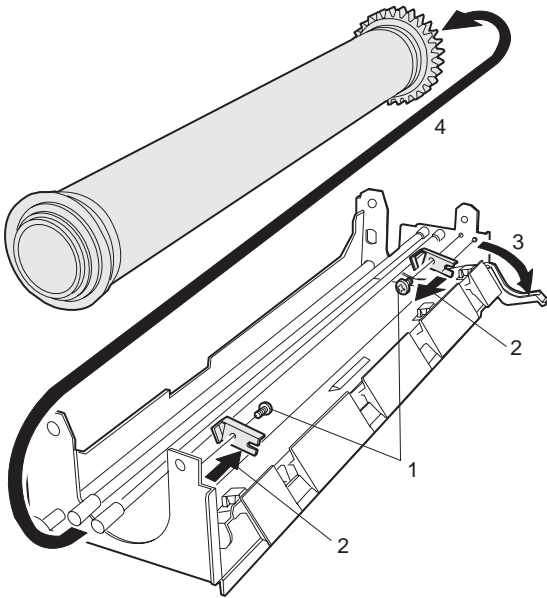
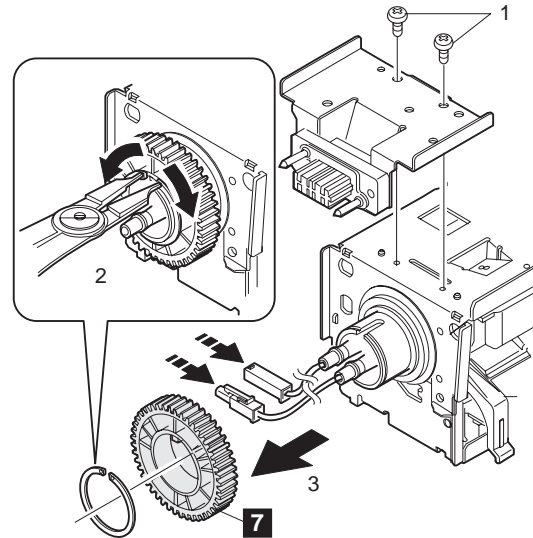
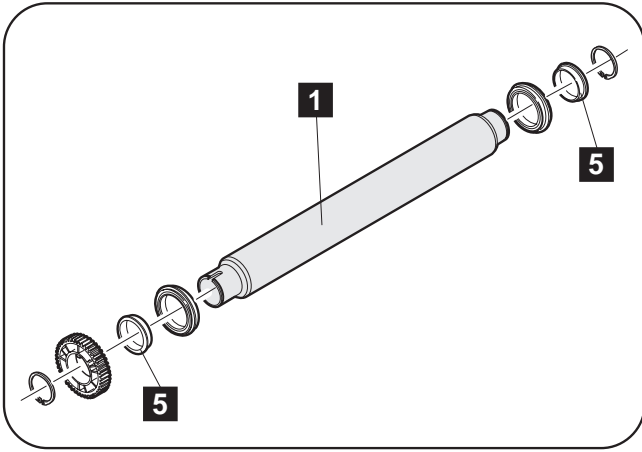

* When assembling, install so that the bearing notches come to the outside of the frame both in the front and the rear sides.

No.	Name	Work item	Cycle			Remark
			AR-250/280/281/ 285/286/335/336	AR-405	AR-501/505	
1	Upper heat roller	Clean	80 K	90 K	125K	
		Replace	160 K	180 K	250K	
2	Lower heat roller	Clean	80 K	90 K	125K	
		Replace	160 K	180 K	250K	
3	Upper separation pawl	Replace	80 K	90 K	125K	
4	Lower separation pawl	Replace	80 K	90 K	125K	
5	Insulation bush	Check	80 K	90 K	125K	
6	Thermistor	Check	80 K	90 K	—	
		Clean	—	—	125K	
7	Upper heat roller gear	Lubricate	80 K	90 K	125K	
		Replace	160 K	180 K	250K	
8	Gears	Lubricate	80K	90 K	125K	

* When assembling the upper frame and the lower frame, press the upper frame securely to the lower frame and fix with the screw. If the frames are fixed loosely, defective fusing and paper wrinkles may occur.

L. Two-tray paper exit unit

(1) Paper exit/transport roller

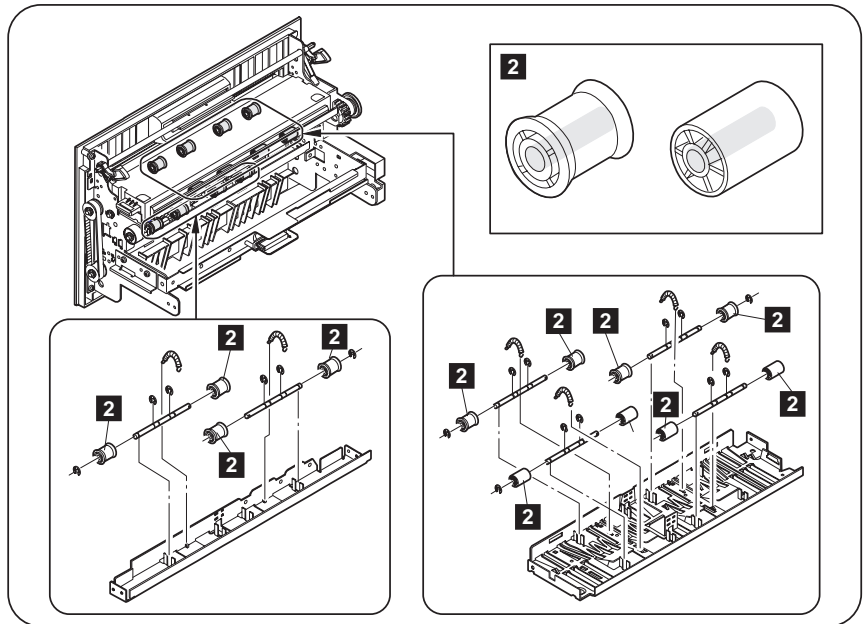
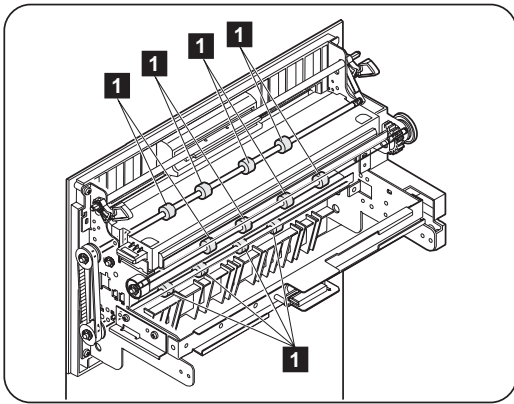
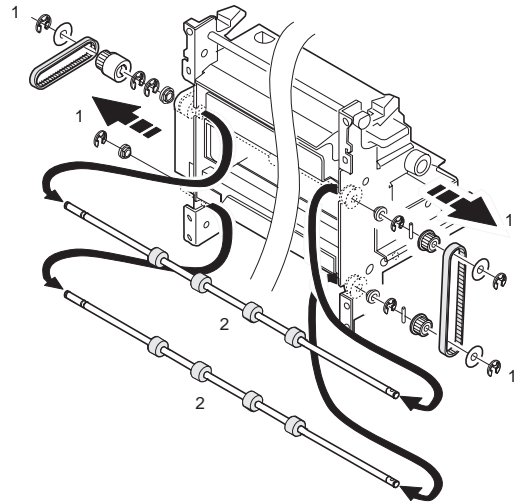
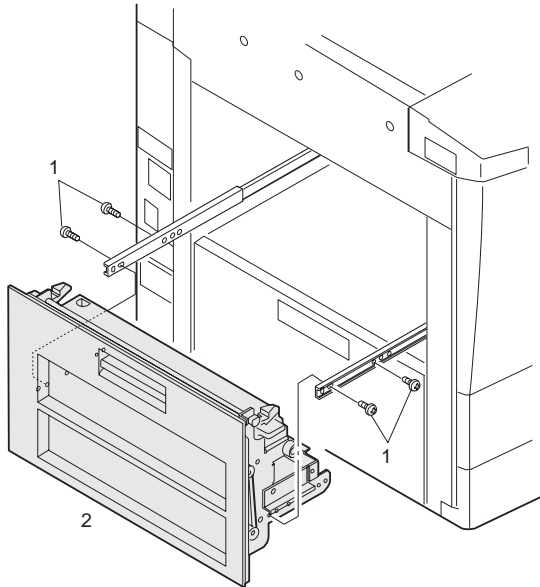
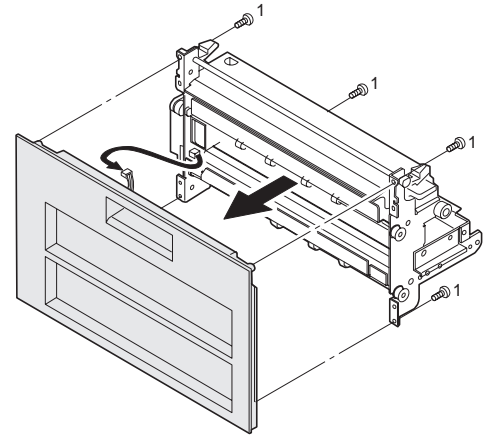
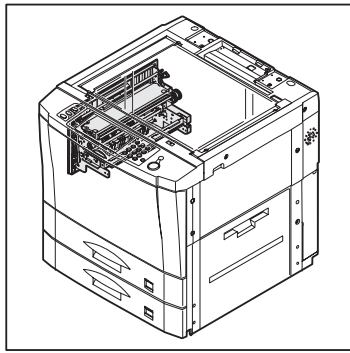

No.	Name	Work item	Cycle	Remark
1	Transport rollers	Clean	80 K	
2	Paper exit follower roller (inner surface)	Lubricate	80 K	

M. One-tray paper unit

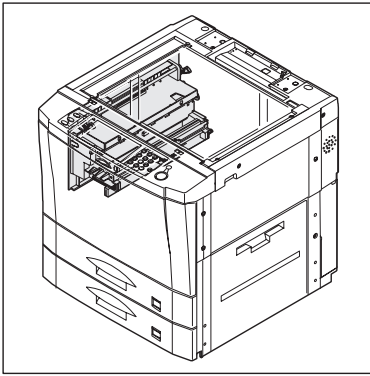

AR-501/505

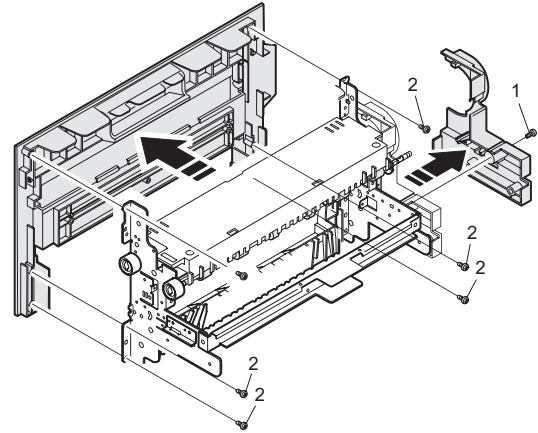
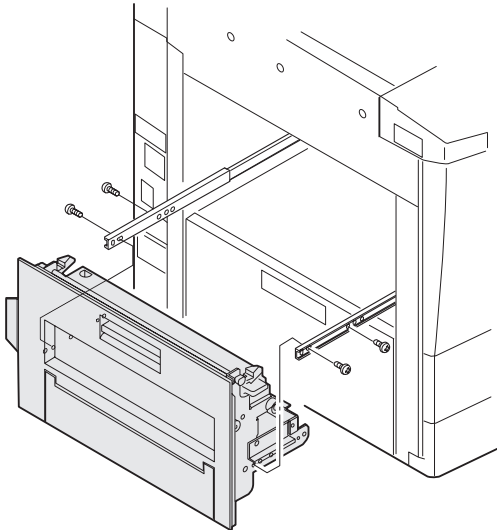
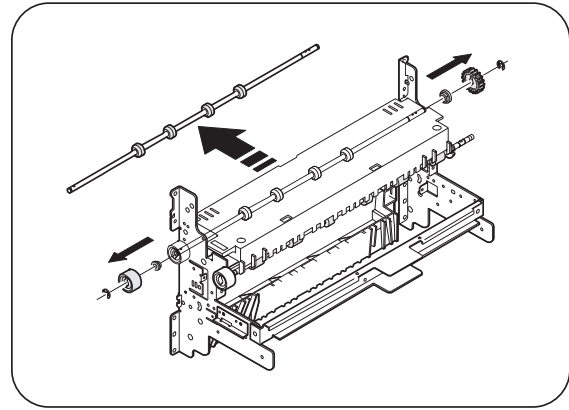

(1) Paper exit roller

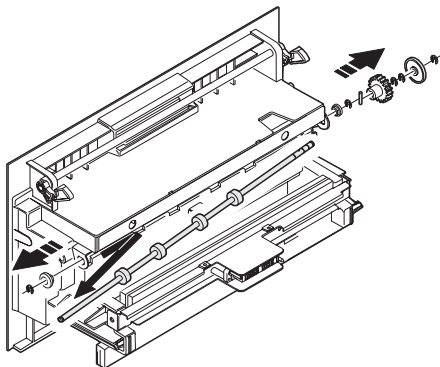

(2) Paper exit/transport roller

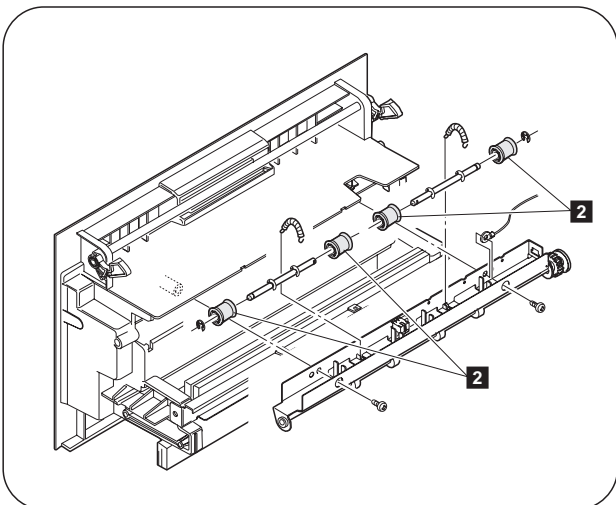
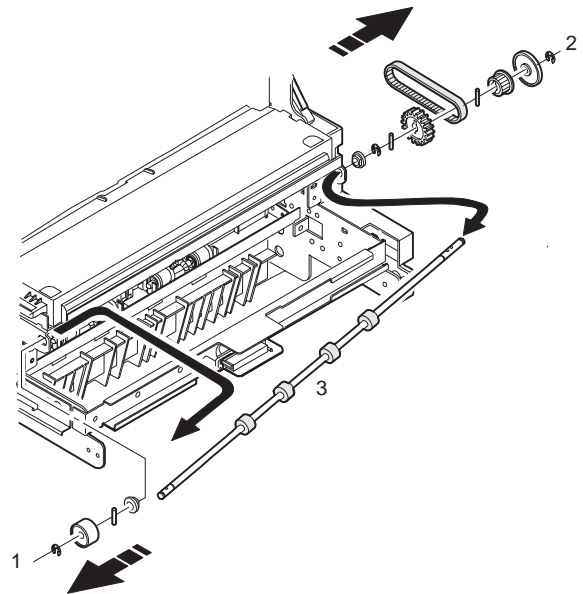

AR-501/505

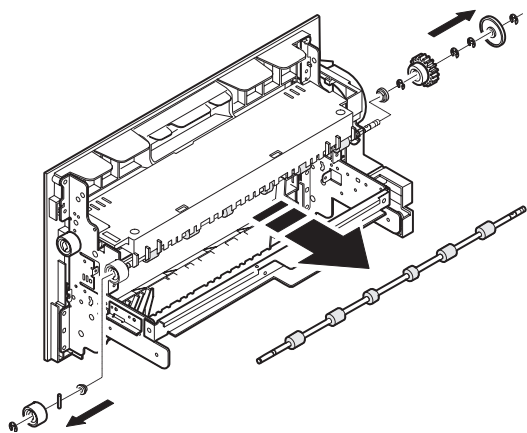

No.	Name	Work item	Cycle			Remark
			AR-280/285/335	AR-405	AR-501/505	
1	Transport rollers	Clean	80 K	90 K	125K	
2	Paper exit follower roller (inner surface)	Lubricate	80 K	90 K	—	
	Paper exit follower roller (inside)	Lubricate	—	—	125K	
3	Curl correction roller	Check	—	—	125K	
		Change	—	—	250K	
4	Transport paper guides	Clean	—	—	125K	

N. PCU/AC power/High voltage power/Main motor

* Do not turn the flywheel manually. Otherwise, the gear may be broken.

(1) PCU/AC power/High voltage power/Main motor

AR-250/280/281/285/286/335/336/405

AR-501/505

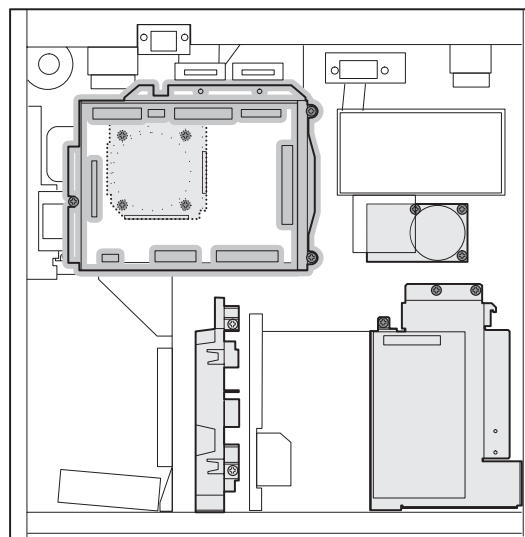
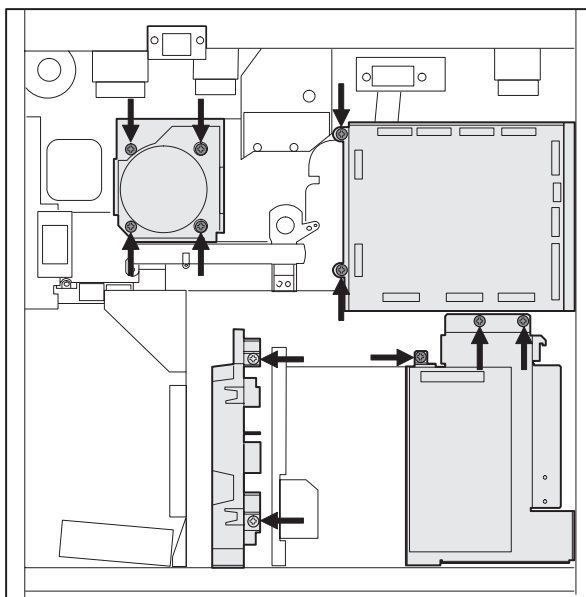

* The PCU, AC power, the high voltage power, and the main motor can be removed by removing the screw shown with arrows.

O. Major drive unit

AR-250/280/281/285/286/335/336/405

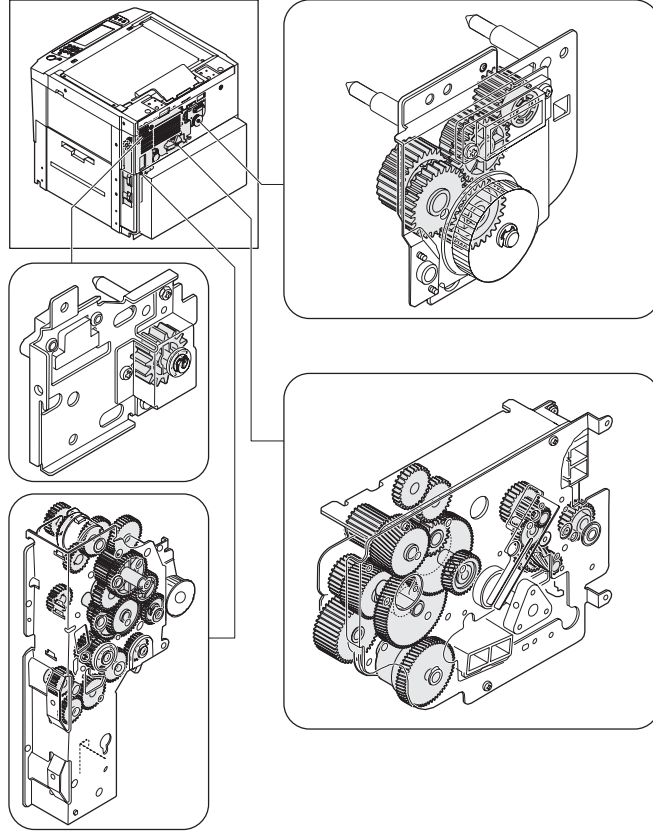

AR-501/505

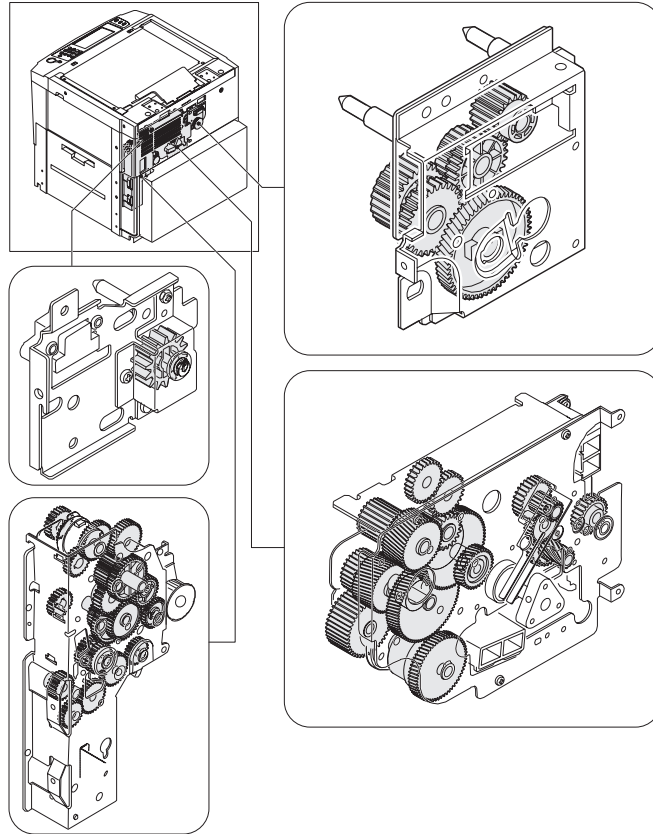

No.	Name	Work item	Cycle			Remark
			AR-250/280/281/ 285/286/335/336	AR-405	AR-501/505	
	Gears	Lubricate	80 K	90 K	125K	
	Belts	Check	240 K	270 K	250K	

AR-250/280/281/285/286/335/336/405

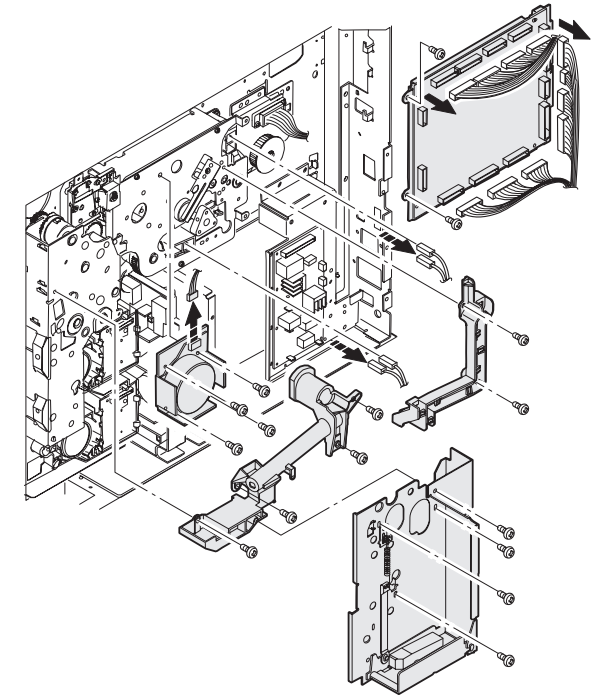

AR-501/505

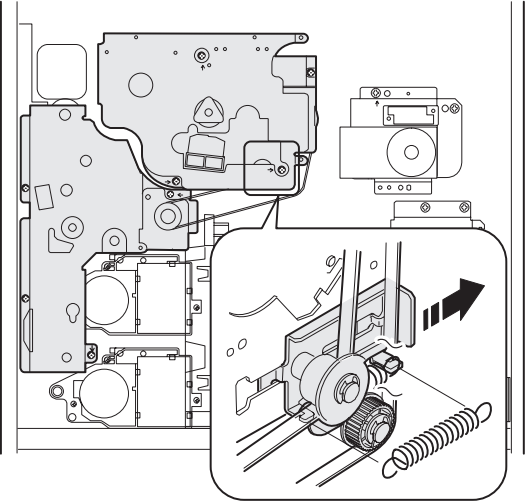
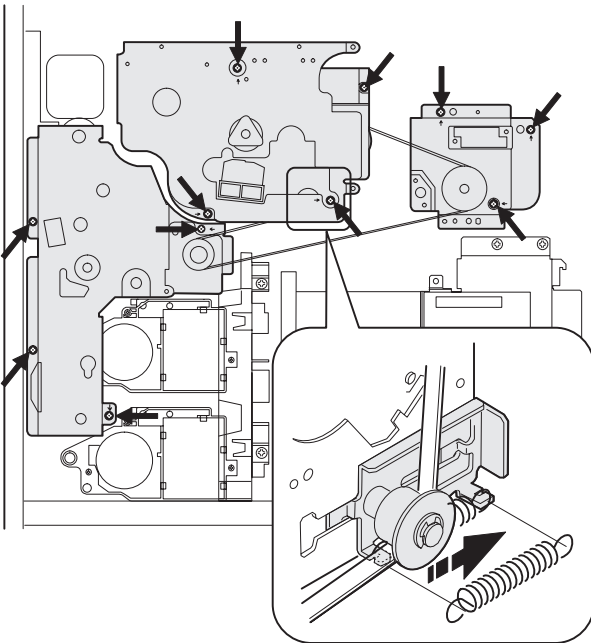
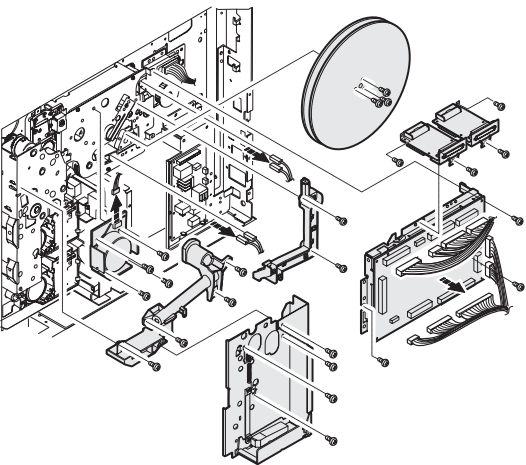

* Each drive unit can be removed by removing the screw shown with the arrow.

Q. RSPF

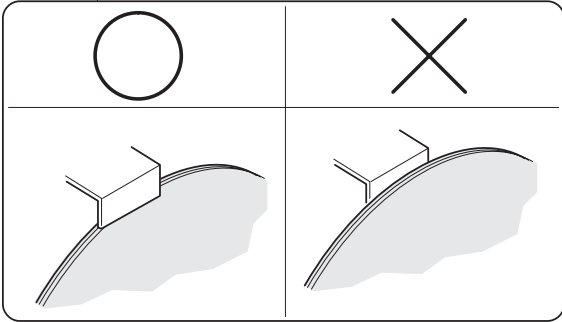
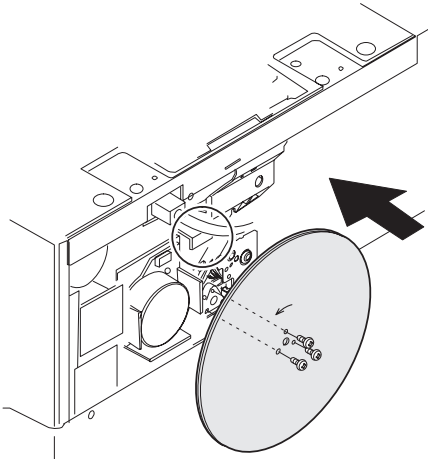

* Note for assembly

- Be sure to attach the flywheel to inside of the guide.
- Attach so that the arrow faces the rotating direction.

P. Lift-up unit

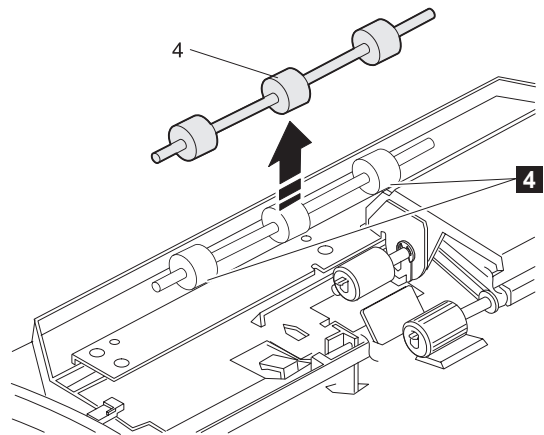
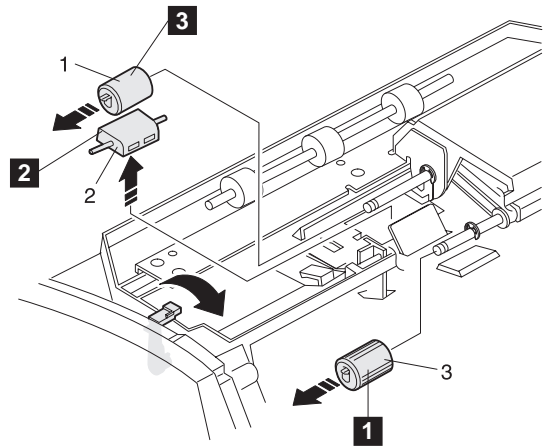
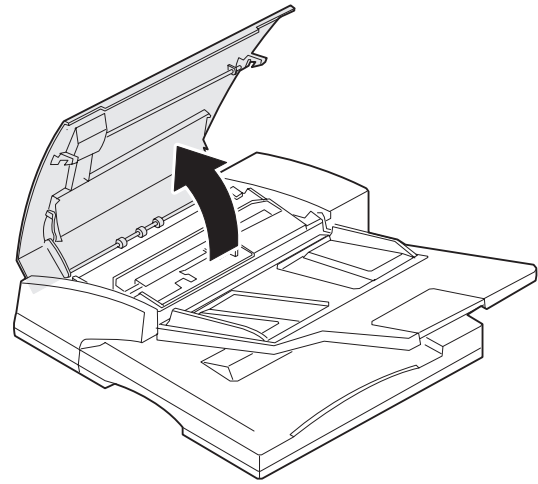
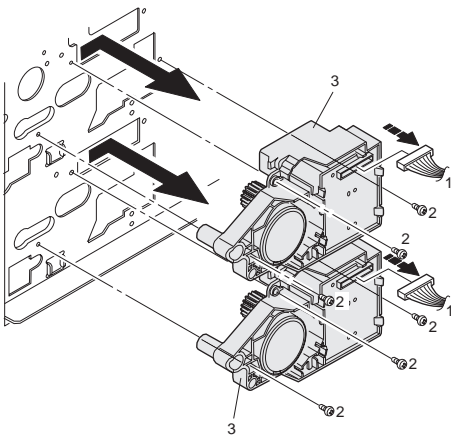
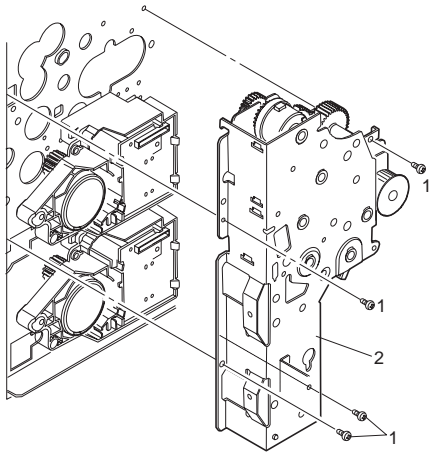

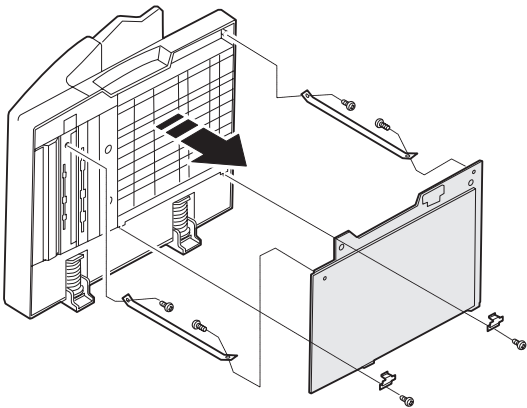
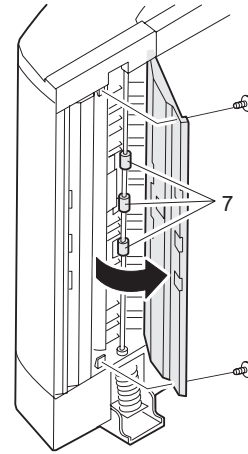
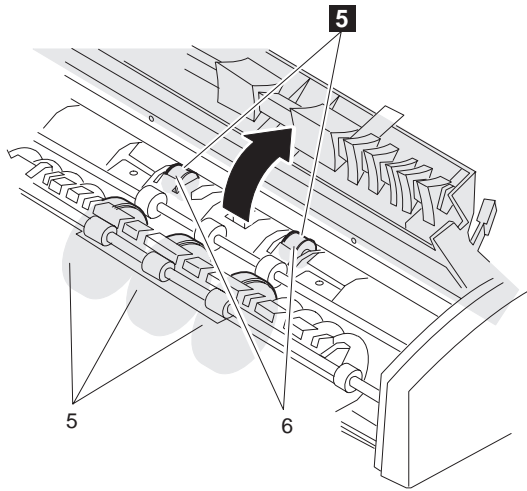

No.	Name	Work item	Cycle			Remark
			AR-335	AR-405	AR-501/505	
1	Pickup roller	Check	—	—	125 K	
2	Separation pad	Check	—	—	125 K	
3	Paper feed roller	Check	—	—	125 K	
4	Resist roller	Clean	—	—	125 K	
5	Paper exit roller	Clean	—	—	125 K	Wipe with alcohol for cleaning.
6	Transport roller	Clean	—	—	125 K	
7	Exposure section	Clean	—	—	125 K	
	Sensors	Clean	—	—	125 K	Blow air for cleaning.

[9] TROUBLE CODE LIST

1. Trouble code

Trouble code	Content of trouble	Remark	Trouble detection
C1	00 MC trouble		PCU
C2	00 TC trouble		PCU
E7	00 ICU communication trouble		ICU
	01 Image data memory trouble		ICU
	02 Laser trouble		ICU
	03 HDD trouble		ICU
	10 Shading trouble (Black correction)		ICU
	11 Shading trouble (White correction)		ICU
	13 CCD light quantity check error		ICU
	90 ICU communication trouble		PCU
F1	00 Finisher communication trouble		PCU
	01 Finisher 1 jogger shift trouble / Finisher 2 alignment section abnormality		FIN
	02 Finisher transport motor abnormality		FIN
	03 Sorter guide bar oscillation motor trouble		SOT
	04 Finisher 1 elevator lower limit detection / Finisher 2 stack tray lower limit detection		FIN
	05 Finisher 1 elevator home / Finisher 2 stack tray sensor abnormality		FIN
	06 Finisher shift motor abnormality		FIN
	08 Finisher staple shift motor trouble		FIN
	10 Finisher staple unit operation trouble		FIN
	11 Finisher 1 pusher motor trouble / Finisher 2 boomerang rotation abnormality		FIN
	14 Finisher 2 stack tray abnormality		FIN
	15 Finisher 1 elevator motor trouble / Finisher 2 stack tray motor lock		FIN
	16 Staple sorter holding moter trouble		SOT
	17 ST paper exit roller pressure release trouble		FIN
	18 Tray 3 paper exit paddler operation trouble		FIN
	50 Non-suport trouble in automatic detection of option connection (Sorter, finisher)		PCU
	80 Finisher power not supplied		FIN
	F2	00 Toner control sensor open	
02 Toner motor connector unconnected			PCU
31 Process control trouble (OPC drum surface reflection rate abnormality)			PCU
32 Process control trouble (Drum marking scanning trouble)			PCU
37 Drum marking sensor gain adjustment error			PCU
39 Process thermistor breakdown			PCU
F3	12 Copier top stage CS lift up trouble		PCU
	22 Copier bottom stage CS lift up trouble		PCU
F9	00 Printer communication trouble		ICU
	01 PRT DRAM trouble		PRT
	02 PRT Centroport check error		PRT
	03 Network card trouble		
	04 Printer program error		
	10 PRT SCSI LSI abnormality		ICU
90 Printer communication trouble		PRT	
H2	00 Thermistor open (HL1)		PCU
	01 Thermistor open (HL2)		PCU
H3	00 Heat roller high temperature detection (HL1)		PCU
	01 Heat roller high temperature detection (HL2)		PCU
H4	00 Heat roller low temperature detection (HL1)		PCU
	01 Heat roller low temperature detection (HL2)		PCU

Trouble code	Content of trouble	Remark	Trouble detection	
H5	01 3 continuous POD1 not-reaching JAM detection		PCU	
	02 Fusing thermistor abnormality		PCU	
L1	00 Scanner feed trouble		PCU	
L3	00 Scanner return trouble		PCU	
L4	01 Main motor lock detection		PCU	
L6	10 Polygon motor lock detection		ICU	
L8	01 No full-wave signal		PCU	
	02 Full-wave signal width abnormality		PCU	
U2	00 EEPROM read/write error		ICU	
	11 Counter check sum error (EEPROM)		ICU	
	12 Adjustment value check sum error (EEPROM)		ICU	
U4	02 ADU alignment plate operation abnormality		PCU	
	03 ADU rear edge plate operation abnormality		PCU	
U5	00 RADF/SPF/RSPF communication trouble		PCU	
	01 RADF resist sensor trouble		RADF	
	02 RADF eject/inversion sensor trouble		RADF	
	03 RADF timing sensor trouble		RADF	
	06 RSPF post-separation sensor trouble		RSPF	
	07 RSPF read sensor trouble		RSPF	
	08 RSPF SB sensor trouble		RSPF	
	11 RADF paper feed motor operation abnormality		RADF	
	16 RSPF fan motor operation abnormality		RSPF	
	U6	00 Desk communication trouble		PCU
		01 Desk 1 CS lift up trouble		Desk
02 Desk 2 CS lift up trouble			Desk	
03 Desk 3 CS lift up trouble			Desk	
08 Desk 24V power abnormality			Desk	
09 LCC lift motor trouble			LCC	
10 Desk transport motor trouble			Desk	
20 LCC communication trouble			PCU	
21 LCC transport motor trouble			LCC	
22 LCC 24V power abnormality			LCC	
50 Non-suport trouble in automatic detection of option connection (Desk unit)			PCU	
51 Non-suport trouble in automatic detection of option connection (LCC unit)			PCU	
U7	00 RIC communication trouble		PCU	
U9	00 Operation control communication trouble		ICU	
	90 Operation control communication trouble		OPE	
EE	EL Auto developing adjustment trouble (Overtoner)	In SIM only	PCU	
	EU Auto developing adjustment trouble (Undertoner)	In SIM only	PCU	
FC	00 ASK/IrDA modulation LSI reset error			
	01 ASK/IrDA switch error			
PC	Personal counter not installed		ICU	
PF	RIC copy inhibit command reception		ICU	
--	Auditor not ready		ICU	

2. Self diagnostics

Trouble code		Description	
Main code	Sub code		
C1	00	Content	MC trouble
		Detail	Main charger output error (output released) Trouble signal from high-voltage transformer
		Cause	Main charger improperly installed Main charger improperly assembled High-voltage transformer connector removed High-voltage harness removed or wire broken
		Check and remedy	Check main charger output with SIM8-2. Check main charger connector for disconnection. Replace high-voltage unit.
C2	00	Content	TC trouble
		Detail	Transfer charger output error (output short-circuiting) Trouble signal from high-voltage transformer
		Cause	Transfer charger contaminated with foreign matter Transfer charger wire broken High-voltage transformer connector disconnected
		Check and remedy	Check transfer charger output with SIM8-6. Replace high-voltage unit.
E7	00	Content	ICU communication trouble (ICU detection)
		Detail	Communication setup error, framing/parity/protocol error
		Cause	Slave unit PWB connector improper connection Slave unit PWB – ICU PWB harness trouble Connector pin breakage of the motor PWB of the slave unit PWB Slave unit ROM trouble. no ROM, ROM reverse insertion, ROM pin breakage
		Check and remedy	Connect the connector of the slave unit PWB and the ICU PWB. Check the connection and the harness. Check the grounding of the copier. Check the ROM of the slave unit PWB.
	01	Content	Image data memory trouble
		Detail	The ICU image data memory (SIMM) is detected only as 8MB or less. The SIMM capacity is insufficient for the model.
		Cause	The ICU PWB SIMM is not installed. The ICU PWB SIMM does not work properly. The ICU PWB SIMM is not installed properly. ICU PWB abnormality
		Check and remedy	Check installation of the ICU PWB SIMM. Check the SIMM capacity with SIM 22-10. Replace the ICU PWB SIMM.

Trouble code		Description	
Main code	Sub code		
E7	02	Content	Laser trouble
		Detail	BD signal from LSU kept at OFF or ON
		Cause	Connector to LSU or harness inside LSU disconnected or wire broken Polygon motor improperly rotating Laser home position sensor improperly positioned inside LSU Laser power supply line does not have proper voltage Laser LED improperly lighting ICU PWB error
		Check and remedy	Check LSU connector for disconnection. Check LSU operation with SIM61-1. Check polygon motor for rotation. Check laser LED for lighting. Replace LSU unit. Replace ICU PWB.
	03	Content	HDD trouble
		Detail	HDD is not recognized in the model with HDD installed.
		Cause	The HDD is not installed to the ICU PWB. The HDD does not work properly in the ICU PWB. The HDD is not installed to the ICU PWB properly. ICU PWB abnormality
		Check and remedy	Check installation of the HDD to the ICU PWB. Check connection of the HDD harness to the ICU. Replace the HDD. Replace the ICU PWB.
	10	Content	Shading trouble (black correction)
		Detail	Improper CCD black reading level for copy lamp going out
		Cause	Improper installation of flat cable to CCD unit CCD unit error ICU PWB error
		Check and remedy	Check flat cable to CCD unit for installation. Check CCD unit. Check ICU PWB.
11	Content	Shading trouble (white correction)	
	Detail	Improper CCD white reference plate reading level for copy lamp lighting	
	Cause	Improper installation of flat cable to CCD unit Mirror, lens or reference white plate contaminated Copy lamp operation error Improperly installed CCD unit CCD unit error ICD PWB error	
	Check and remedy	Clean mirror, lens, or reference white plate. Check copy lamp for light amount (SIM5-3) and lighting. Check CCD unit. Check ICU PWB.	

Trouble code		Description		
Main code	Sub code			
E7	13	Content	CCD light quantity check error	
		Detail	Copy lamp light amount adjustment in shading cannot be made	
		Cause	Copy lamp does not light (broken wire, improper installation) Improper installation of flat cable to CCD unit Improper connection of copy lamp CL lead wire Mirror, lens, or reference white plate Dirt or dew Improper output of copy lamp power supply Improper installation of CCD unit CCD unit error ICU PWB error	
		Check and remedy	Clean mirror, lens, reference white plate. Check copy lamp for light amount (SIM5-3) and lighting. Check CCD unit. Check ICU PWB.	
	90	Content	ICU communication trouble (PCU detection)	
		Detail	Communication setup error/framing/parity/protocol error	
		Cause	Slave unit PWB connector improper connection Slave unit PWB – ICU PWB harness trouble Slave unit PWB mother board connector pin breakage	
		Check and remedy	Check the slave unit PWB and the ICU PWB connector connection. Check the copier earth.	
	F1	00	Content	Finisher communication trouble
			Detail	Communication line test error occurs when power is turned on or after the exit of a simulation mode. Improper communication with sorter
Cause			Improper connection or broken wire of connector or harness between copier and sorter Finisher control PWB defective Control PWB (PCU) defective Malfunction due to noise	
Check and remedy			Clear by turning the power supply OFF/ON. Check communication line connector and harness. Replace Finisher control PWB or PCU PWB.	
01		Content	Finisher1 jogger shift trouble / Finisher 2 alignment section abnormality	
		Detail	Jogger shift trouble / Alignment plate shift trouble	
		Cause	Motor lock Motor rpm abnormality Motor overcurrent Finisher control PWB trouble	
		Check and remedy	Check the jogger motor operation with SIM 3-3.	

Trouble code		Description	
Main code	Sub code		
F1	02	Content	Finisher transport motor abnormality
		Detail	Transport motor drive trouble
		Cause	Motor lock
		Check and remedy	Check transport motor operation with SIM3-3.
	03	Content	Sorter guide bar oscillation motor trouble
		Detail	Sorter guide bar oscillation motor drive abnormality
		Cause	Motor lock. Motor rotation abnormality. Overcurrent to motor Sorter control PWB abnormality
		Check and remedy	Check the guide bar motor operation with SIM3-3.
	04	Content	Finisher 1 elevator lower limit detection/ Finisher 2 stack tray lower limit detection
		Detail	When the bin is shifted, the upper limit or the lower limit sensor is detected. / The elevator exceeds the lower limit.
		Cause	Sensor defective Sorter/finisher control PWB abnormality
		Check and remedy	Check sensor with SIM3-2.
	05	Content	Finisher 1 elevator home / Finisher 2 stack tray sensor abnormality
		Detail	The elevator does not detect the home position. / Stack tray sensors are turned on in the abnormal combination.
		Cause	Sensor defective Sorter/finisher control PWB abnormality
		Check and remedy	Check sensor with SIM3-2.
06	Content	Finisher shift motor abnormality	
	Detail	1) Bin shift is not completed within 2.5 seconds after bin shift request	
	Cause	Motor lock Improper motor speed Overcurrent to motor Finisher control PWB defective	
	Check and remedy	Check bin shift motor operation with SIM3-4.	
08	Content	Finisher staple shift motor trouble	
	Detail	Staple motor drive trouble	
	Cause	Motor lock Motor rpm abnormality Overcurrent to motor Finisher control PWB trouble	
10	Content	Finisher staple unit operation trouble	
	Detail	Staple operation trouble	
	Cause	Motor lock Motor rpm abnormality Motor overcurrent Finisher control PWB trouble	
	Check and remedy	Check the staple motor operation with SIM 3-3.	

Trouble code		Description	
Main code	Sub code	Description	
F1	11	Content	Finisher 1 pusher motor trouble / Finisher 2 boomerang rotation abnormality
		Detail	Pusher motor trouble / Paddle solenoid abnormality
		Cause	Motor lock / paddle solenoid operation abnormality / boomerang rotation sensor abnormality Motor rpm abnormality Motor overcurrent Finisher control PWB abnormality
		Check and remedy	Check the finisher motor operation, the paddle solenoid operation with SIM 3-3 or check the boomerang rotation sensor with SIM 3-2.
		14	Content
	Detail	Stack tray control sensor abnormality	
	Cause	The paper surface sensor and the full stack sensor do not turn on even when a certain time is passed after starting the tray.	
	Check and remedy	Check the sensor operation with SIM 3-2.	
	15	Content	Finisher 1 elevator motor trouble / Finisher 2 stack tray motor lock
	Detail	Elevator motor trouble	
	Cause	Motor lock Motor rpm abnormality Motor overcurrent Finisher control PWB trouble	
	Check and remedy	Check the elevator motor operation with SIM 3-3.	
	16	Content	Staple sorter holding motor trouble
	Detail	During rotation of the holding motor, the rotation pulse is not detected for 0.05sec or more.	
	Cause	Motor lock. Motor rotation abnormality. Overcurrent to motor Sorter control PWB abnormality	
	Check and remedy	Check the holding motor operation with SIM3-3.	
	17	Content	ST pressure release HP trouble
	Detail	ST paper exit roller pressure release trouble when turning on the power/initializing	
	Cause	ST paper exit roller pressure release clutch abnormality ST paper exit roller pressure release clutch HP sensor abnormality	
	Check and remedy	Stop the transport motor in SIM 3-3, turn on the STORCL to check that the pressure release roller operates. Check the STORHP sensor with SIM 3-2.	
18	Content	Tray 3 paper exit paddler operation trouble	
Detail	Tray 3 paper exit paddler operation trouble when turning on the power/initializing		
Cause	Tray 3 paper exit paddler solenoid abnormality Tray 3 paper exit paddler HP sensor abnormality Finisher control PWB trouble		
Check and remedy	Operate the transport motor with SIM 3-3 and turn on T3PDSL to check that tray 3 paddler operates. Check T3PDHP sensor with SIM 3-2.		

Trouble code		Description		
Main code	Sub code	Description		
F1	50	Content	Non-support trouble in automatic detection of option connection (Sorter, finisher)	
		Detail	In automatic detection of option connection, a non-support finisher or a sorter is detected.	
		Cause	A non-support finisher or a sorter is connected to the copier.	
		Check and remedy	Check the finisher or the sorter.	
		80	Content	Finisher power not supplied
	Detail	24V power is not supplied to the finisher PWB.		
	Cause	Connector harness improper connection or disconnection Finisher control PWB trouble Power unit trouble		
	Check and remedy	Check the sensor operation with SIM 3-2.		
	F2	00	Content	Toner control sensor open
			Detail	Toner control sensor output open
Cause			Connector harness trouble Connector unconnected.	
Check and remedy			Check connection of the toner control sensor. Check connection of the connector harness with the main PWB. Check for disconnection of the harness.	
02		Content	Toner motor connector unconnected	
		Detail	Connection detection signal with toner motor is OFF	
		Cause	Connector harness defective Connector disconnected	
Check and remedy		Check toner motor connector for connection. Check connector harness to main PWB for connection. Check harness for broken wire.		
31		Content	Process control trouble (OPC drum surface reflection rate abnormality)	
		Detail	Usually the sensor gain is adjusted so that the output is a certain value, by reading the drum base surface with the image density sensor before starting process control. However, a certain output is not obtained by adjusting the sensor gain.	
	Cause	Image density sensor defective		
	Check and remedy	Check process control sensor output with SIM44-2. (Do not adjust) If the result is far different from the specified value, it suggests the sensor is defective. Check the sensor and harness. If the deviation is relatively small, check the sensor and drum surface for contamination.		

Trouble code		Description	
Main code	Sub code		
F2	32	Content	Process control trouble (Drum marking scanning trouble)
		Detail	Usually the sensor gain is adjusted so that the output is a certain value, by reading the drum base surface with the drum marking sensor before starting process control. However, a certain output is not obtained by adjusting the sensor gain.
		Cause	Drum marking sensor defective Improper connection of harness between PCU PWB and drum marking sensor Drum marking sensor contaminated OPC drum cleaning improper Charging voltage improper
		Check and remedy	Check process control output with SIM44-02. (Do not adjust.) If the result is far different from the specified value, it suggests the sensor is defective. Check the sensor and harness. If the deviation is relatively small, check the sensor and drum surface for contamination.
	37	Content	Drum marking sensor gain adjustment error
		Detail	When the drum marking area surface is scanned with the drum marking sensor before starting process control and the sensor gain is adjusted until a constant output is provided, the output is not constant though the sensor gain is changed.
		Cause	Drum marking sensor trouble Improper connection between PCU PWB and drum marking sensor Drum marking sensor is dirty OPC drum cleaning trouble
		Check and remedy	Perform the gain adjustment of process control sensor with SIM 44-2. If ERROR is displayed, it may be a breakdown. Check the sensor and the harness. When the adjustment is completed, check the drum surface conditions.
	39	Content	Process thermistor breakdown
		Detail	The process thermistor is open.
		Cause	Process thermistor abnormality Improper connection of the process thermistor bar PCU PWB abnormality
		Check and remedy	Check connection of the process thermistor harness and connector. Check the PCU PWB.
F3	12	Content	Copier top stage CS lift up trouble
		Detail	UPED does not turn on within the specified time. ULUD does not turn on within the specified time.
		Cause	UPED or ULUD defective Upper cassette lift-up motor defective Improper connection of harness between PCU PWB, lift-up unit, and paper feed unit.
		Check and remedy	Check UPED, ULUD and their harness and connector. Check lift-up unit.

Trouble code		Description		
Main code	Sub code			
F3	22	Content	Copier bottom stage CS lift up trouble	
		Detail	LPED does not turn on within the specified time. LLUD does not turn on within the specified time.	
		Cause	LPED or LLUD defective Lower cassette lift-up motor defective Improper connection of harness between PCU PWB, lift-up unit, and paper feed unit.	
		Check and remedy	Check LPED, LLUD, their harnesses and connectors. Check lift-up unit.	
	F9	00	Content	Printer communication trouble (ICU detection)
			Detail	Communication setup error, framing/parity/protocol error
			Cause	Slave unit PWB connector improper connection Slave unit PWB – ICU PWB harness trouble Connector pin breakage of the motor PWB of the slave unit PWB Slave unit ROM trouble. no ROM, ROM reverse insertion, ROM pin breakage
			Check and remedy	Connect the connector of the slave unit PWB and the ICU PWB. Check the connection and the harness. Check the grounding of the copier. Check the ROM of the slave unit PWB.
		01	Content	PRT DRAM trouble
			Detail	Option printer PWB DRAM trouble (Check when turning on the power.)
			Cause	DRAM module is broken and access cannot be made. DRAM module improper installation
			Check and remedy	Check with SIM 67-1.
03	Content	Network card trouble.		
	Detail	Network card self test trouble.		
	Cause	Network card defect. Printer PWB defect. Network card connector connection defect.		
	Check and remedy	Check the Network card connector. Replace the printer PWB. Replace the Network card.		
04	Content	Printer program error.		
	Detail	Program data trouble in the option printer board.		
	Cause	Flash memory data is destroyed.		
	Check and remedy	Replace or rewrite the Flash memory. Replace the printer PWB.		
10	Content	PRT SCSI LSI abnormality		
	Detail	An error occurred in SCSI communication with the option printer board.		
	Cause	SCSI LSI abnormality ISU PWB abnormality SCSI connector improper connection		
	Check and remedy	Replace the printer PWB. Check the SCSI connector. Replace the ISU PWB.		

Trouble code		Description	
Main code	Sub code		
F9	90	Content	Printer communication trouble (PRT detection)
		Detail	Communication setup error/framing/parity/protocol error
		Cause	Slave unit PWB connector improper connection Slave unit PWB – ICU PWB harness trouble Slave unit PWB mother board connector pin breakage
		Check and remedy	Check the slave unit PWB and the ICU PWB connector connection. Check the copier earth.
H2	00...HL1 01...HL2	Content	Thermister open Fusing unit not installed
		Detail	Thermister is open (more than 4.6-V input voltage is detected). Fusing unit not installed
		Cause	Thermister defective Control PWB defective Improper connection of fusing connector AC power supply defective Fusing unit not installed
		Check and remedy	Check harness and connector between thermister and control PWB. Clear the display of self-diagnostics with SIM14.
H3	00...HL1 01...HL2	Content	Heat roller high temperature detection
		Detail	The fusing temperature is over 241.5°C (less than 1.3-V input voltage is detected.)
		Cause	Thermister defective Control PWB defective Improper connection of fusing unit connector AC power supply defective
		Check and remedy	Check heater lamp operation with SIM5-2. If lamp blinks properly: Check thermister and its harness. Check thermister input circuit of control PWB. If lamp lights and stays lit: Check lamp control circuits of AC PWB and control PWB. Clear the trouble with SIM14.

Trouble code		Description	
Main code	Sub code		
H4	00...HL1 01...HL2	Content	Heat roller low temperature detection
		Detail	The temperature does not reach the preset value within the specified time (3 min. in usual modes; 5 min. in curl correction mode.) after the power relay is turned on.
		Cause	Thermister defective Heater lamp defective Control PWB defective Thermostat defective AC power supply defective Interlock switch defective
		Check and remedy	Check heater lamp for blinking with SIM5-2. If lamp blinks properly: Check thermister and its harness. Check thermister input circuit of control PWB. If lamp does not light: Check heater lamp for broken wire and thermostat for operation. Check interlock switch. Check lamp control circuit of AC PWB and control PWB. Clear the trouble with SIM14.
H5	01	Content	3 continuous POD1 not-reaching JAM detection
		Detail	3 continuous POD1 not-reaching JAM detection
		Cause	Check that the fusing JAM is completely cancelled. (Jam paper may be remained.) POD1 sensor trouble or improper harness connection Improper installation of the fusing harness.
	02	Content	Fusing thermistor abnormality
		Detail	Fusing thermistor temperature transient abnormality (Paper winding)
		Check and remedy	Check for jam (winding) paper in the fusing section. Check for installation of the fusing unit. Check the fusing pawl. Cancel the trouble with SIM 14.
L1	00	Content	Scanner feed trouble
		Detail	Scanner feed is not finished within the specified time. (timer is change by magnification)
		Cause	Mirror unit defective Scanner wire disconnected
		Check and remedy	Check scanning operation with SIM1-1.

Trouble code		Description	
Main code	Sub code		
L3	00	Content	Scanner return trouble
		Detail	Scanner return is not finished within the specified time. (timer is change by magnification)
		Cause	Mirror unit defective Scanner wire disconnected
		Check and remedy	Check scanning operation with SIM1-1.
L4	01	Content	Main motor lock detection
		Detail	Motor lock signal is detected for 1.5 seconds during main motor rotation
		Cause	Main motor defective Improper connection of harness between PCU PWB and main motor Control circuit defective
		Check and remedy	Check main motor operation with SIM25-1. Check harness and connector between PCU PWB and main motor.
L6	10	Content	Polygon motor lock detection
		Detail	It was judged that there is no output of polygon motor lock signal of LSU. The lock signal was checked at about 10-second intervals after the polygon motor started rotating. As result, it was judged that the polygon motor failed to operate normally.
		Cause	Disconnected connector to LSU or detached harness inside LSU or broken wire. Polygon motor defective
		Check and remedy	Check polygon motor operation with SIM61-1. Check harness and connector for connection. Replace LSU if needed.
L8	01	Content	No full-wave signal
		Detail	Full-wave signal is not detected.
		Cause	PCU PWB trouble Power unit trouble
		Check and remedy	Check connection of the harness and the connector. Replace the PCU PWB. Replace the power unit.
	02	Content	Full-wave signal with abnormality
		Detail	Full-wave signal frequency abnormality detected. (The detected frequency: 69Hz or above or 42.5Hz or below)
		Cause	Check for disconnection or improper connection of the connector of the PCU PWB and the power PWB harness. PCU PWB trouble Power unit trouble
		Check and remedy	Check connection of the harness and connector. Replace the power unit.

Trouble code		Description	
Main code	Sub code		
U2	00	Content	EEPROM read/write error
		Detail	EEPROM version error. Error in writing into EEPROM.
		Cause	EEPROM defective Uninitialized EEPROM is installed Defective EEPROM access circuit on PCU PWB
		Check and remedy	Check EEPROM for proper set-up To prevent the erasure of counter data and adjustment values, write down the counter data and adjustment values by simulation. (If there is a printer option, execute SIM23-1 and note counter data/adjustment values.) Clear U2 trouble with SIM16. Replace PCU PWB.
	11	Content	Counter check sum error (EEPROM)
		Detail	Checksum error in counter data area
		Cause	EEPROM defective Control circuit hung up due to noise Defective EEPROM access circuit on PCU PWB
	Check and remedy	Check EEPROM for proper set-up To prevent the erasure of counter data and adjustment values, write down the counter data and adjustment values by simulation. (If there is a printer option, execute SIM23-1 and note counter data/adjustment values.) Clear U2 trouble with SIM16. Replace PCU PWB.	
U2	12	Content	Adjustment value check sum error (EEPROM)
		Detail	Checksum error in adjustment value data area
	Cause	EEPROM defective Control circuit hung up due to noise. Defective EEPROM access circuit on PCU PWB	
		Check and remedy	Check EEPROM for proper set-up To prevent the erasure of counter data and adjustment values, write down the counter data and adjustment values by simulation. (If there is a printer option, execute SIM23-1 and note counter data/adjustment values.) Clear U2 trouble with SIM16. Replace PCU PWB.

Trouble code		Description		
Main code	Sub code			
U4	02	Content	ADU alignment plate operation abnormality	
		Detail	The plate won't move from home position more than 1 second after sending the command to leave home position. Or the plate won't return to home position within 5 seconds after sending the command to return to home position.	
		Cause	Home position sensor defective Alignment shift motor defective Improper connection of harness between PCU PWB, motor and sensor. Control PWB (PCU) defective Alignment plate driving belt or gear damaged or improperly adjusted	
		Check and remedy	Check home position sensor detection with SIM9-2. Check alignment plate operation with SIM9-4. Check connection between PCU, motor and sensor. Remove ADU and check gear and belt for damage.	
	03	Content	ADU rear edge plate operation abnormality	
		Detail	When the plate is not shifted from the home position for 1 sec or more or when returning to the home position is not detected for 5 sec or more.	
		Cause	Home position sensor defect Rear edge plate shift motor defect Control PWB (PCU) defect Rear edge plate operation belt/gear damage or adjustment error	
		Check and remedy	Check the home position sensor operation with SIM 9-21. Check the rear edge plate operation with SIM 9-31. Check between the PCU PWB, the motor, and the sensor. Remove the ADU and check the gear and the belt.	
	U5	00	Content	RADF/SPF/RSPF communication trouble
			Detail	Communication line test error occurs when power is turned on or after the exit of a simulation mode. Improper communication with RADF
Cause			Improper connection or broken wire of connector or harness RADF control PWB defective Control PWB (PCU) defective Malfunction due to noise	
Check and remedy			Check communication line connector and harness. Clear the trouble by turning power supply On/Off.	
01		Content	RADF resist sensor trouble	
		Detail	RADF resist sensor detection trouble	
		Cause	Sensor defective Improper connection of sensor harness inside RADF. RADF control PWB defective	
		Check and remedy	Check resist sensor detection with SIM2-2. Check sensor harness inside RADF.	

Trouble code		Description		
Main code	Sub code			
U5	02	Content	RADF eject/inversion sensor trouble	
		Detail	RADF eject/inversion sensor detection trouble	
		Cause	Defective sensor Improper connection of sensor harness inside RADF. RADF control PWB defective	
		Check and remedy	Check eject/inversion sensor detection with SIM2-2. Check sensor harness inside RADF.	
		03	Content	RADF timing sensor trouble
			Detail	RADF timing sensor detection trouble
	Cause		Defective sensor Improper connection of sensor harness inside RADF RADF control PWB defective	
	06	Check and remedy	Check timing sensor detection with SIM2-2. Check sensor harness inside RADF.	
		Content	RSPF post-separation sensor trouble	
		Detail	RSPF post-separation sensor detection trouble (in auto adjustment).	
	07	Cause	Sensor trouble. Bad connection of sensor harness in RSPF. RSPF control PWB trouble. Erroneous detection by paper dust.	
		Check and remedy	Check detection of post-separation sensor with SIM2-2. Check RSPF sensor harness. Clean and remove paper dust.	
		Content	RSPF read sensor trouble	
	08	Detail	RSPF read sensor detection trouble (in auto adjustment)	
		Cause	Sensor trouble. Bad connection of sensor harness in RSPF. RSPF control PWB trouble. Erroneous detection by paper dust.	
		Check and remedy	Check detection of read sensor with SIM2-2. Check RSPF sensor harness. Clean and remove paper dust.	
	11	Content	RADF paper feed motor operation abnormality	
		Detail	Paper feed motor driving error	
Cause		Motor lock Improper motor speed Overcurrent to motor RADF control PWB defective		
Check and remedy		Check paper feed motor operation with SIM2-3,4.		

Trouble code		Description	
Main code	Sub code		
U5	16	Content	RSPF fan motor operation abnormality
		Detail	An abnormality is detected by the input of RSPF fan motor alarm signal.
		Cause	Motor lock. RSPF control PWB trouble. Bad connection of RSPF motor harness.
		Check and remedy	Check the fan motor operation with SIM2-2.
U6	00	Content	Desk communication trouble
		Detail	Failed communication with desk Communication line test error occurs when power is turned on or after the exit of a simulation mode.
		Cause	Improper connection or broken wire of connector or harness Desk control PWB defective Control PWB (PCU) defective Malfunction due to noise.
		Check and remedy	Clear the trouble by turning the power supply On/Off. Check communication line connector and harness.
	01 – 03	Content	Desk 1, 2, 3 CS lift-up trouble
		Detail	Desk cassette lift-up trouble (1st - 3rd cassettes).
		Cause	Defective sensor RADF control PWB defective Broken gear Lift-up motor defective
		Check and remedy	Check lift-up sensor detection with SIM4-2. Check lift-up motor with SIM4-3.
	08	Content	Desk 24-V power abnormality
		Detail	No supply of DC24V to desk
		Cause	Improper connection or broken wire of connector or harness Desk control PWB defective Power supply unit defective
		Check and remedy	Check power supply line connector and harness. Check 24-V voltage on power supply unit and desk control PWB.
	09	Content	LCC lift motor trouble
		Detail	LCC lift motor trouble
		Cause	Sensor trouble LCC control PWB trouble Gear breakage Lift motor trouble
		Check and remedy	Check the sensor detection with SIM 4-2. Check the lift motor operation with SIM 4-3.
10	Content	Desk transport motor trouble	
	Detail	Desk transport motor operation trouble	
	Cause	Motor lock Improper motor speed Overcurrent to motor RADF control PWB defective	
	Check and remedy	Check transport motor operation with SIM4-6.	

Trouble code		Description	
Main code	Sub code		
U6	20	Content	LCC communication trouble
		Detail	LCC communication trouble Error when power is turned on or in communication line test after exiting SIM.
		Cause	Connector harness improper connection or disconnection LCC control PWB trouble Control PWB (PCU) trouble Malfunction by noise
		Check and remedy	Canceled by turning on the power. Check the connector and harness of the communication line.
	21	Content	LCC transport motor trouble
		Detail	LCC transport motor operation trouble
		Cause	Motor lock Motor rpm abnormality Motor overcurrent LCC control PWB trouble
		Check and remedy	Check the transport motor operation with SIM 4-3.
	22	Content	LCC 24V power abnormality
		Detail	DC24V not supplied to LCC
		Cause	Connector harness improper connection or disconnection LCC control PWB trouble Power unit trouble
		Check and remedy	Check the connector and harness of power line. Check 24V power in the power unit and the LCC control PWB.
	50	Content	Non-support trouble in automatic detection of option connection (Desk unit)
		Detail	In automatic detection of option connection, a non-support desk unit is detected.
		Cause	A non-support desk unit is connected to the copier.
		Check and remedy	Check the desk unit.
51	Content	Non-support trouble in automatic detection of option connection (LCC unit)	
	Detail	In automatic detection of option connection, a non-support LCC unit is detected.	
	Cause	A non-support LCC unit is connected to the copier.	
	Check and remedy	Check the LCC unit.	
U7	00	Content	RIC communication trouble
		Detail	Communication error with RIC Error in communication line test after turning on the power or exiting from SIM.
		Cause	Improper connection or disconnection of connector and harness RIC control PWB trouble Control PWB (ICU) trouble Malfunction caused by noises
		Check and remedy	Turn off/on the power to cancel the trouble.

Trouble code		Description	
Main code	Sub code		
U9	00	Content	Operation control communication trouble (ICU detection)
		Detail	Communication setup error, framing/parity/protocol error
		Cause	Slave unit PWB connector improper connection Slave unit PWB – ICU PWB harness trouble Connector pin breakage of the motor PWB of the slave unit PWB Slave unit ROM trouble. no ROM, ROM reverse insertion, ROM pin breakage
		Check and remedy	Connect the connector of the slave unit PWB and the ICU PWB. Check the connection and the harness. Check the grounding of the copier. Check the ROM of the slave unit PWB.
	90	Content	Operation control communication trouble (OPE detection)
		Detail	Communication setup error/framing/parity/protocol error
		Cause	Slave unit PWB connector improper connection Slave unit PWB – ICU PWB harness trouble Slave unit PWB mother board connector pin breakage
		Check and remedy	Check the slave unit PWB and the ICU PWB connector connection. Check the copier earth.
EE	EL	Content	Auto developing adjustment trouble (overtoner)
		Detail	A sample data is less than 0 when auto developing adjustment is executed.
		Cause	Toner density sensor defective Charging voltage or developing voltage improper. Toner density improper Developing unit defective PCU PWB defective
		Check and remedy	Make auto developing adjustment with SIM25-2.
	EU	Content	Auto developing adjustment trouble (undertoner)
		Detail	A sample data is less than 99 when auto developing adjustment is executed.
		Cause	Toner density sensor defective Charging voltage or developing voltage improper Toner density improper Unit defective PCU PWB defective
		Check and remedy	Make auto developing adjustment with SIM25-2.

Trouble code		Description	
Main code	Sub code		
FC	00	Content	ASK/IrDA modulation LSI reset error
		Detail	Though the RESET signal pulse is sent to the ASK/IrDA modulation LSI, the power signal is not turned ON.
		Cause	1) ICU main PWB defect 2) ASK/IrDA modulation LSI/Clock oscillator defect
		Check and remedy	Perform the self diag with SIM 68-01. Replace the ICU main PWB.
	01	Content	ASK/IrDA switch error
		Detail	Though the ASK/IrDA switch command is sent to the ASK/IrDA modulation LSI, the AI signal is not changed.
		Cause	1) ICU main PWB defect 2) ASK/IrDA modulation LSI/Clock oscillator defect
		Check and remedy	Perform the self diag with SIM 68-01. Replace the ICU main PWB.
PF	00	Content	RIC copy inhibition command reception
		Detail	Copy inhibition command received from RIC (host)
		Cause	Judged by the host.
		Check and remedy	Notice to the host
—		Content	Auditor not ready

[10] OPERATIONAL DESCRIPTION

Correcting operation in the image forming section (Process correction operation)

1. Outline and purpose

The operations of the image forming section are corrected in order to maintain stable and high-quality print even when changes occur in the temperature, humidity, consumable parts characteristics, engine conditions, or other environmental conditions.

The correction is performed by controlling various parameters related to the image forming section (process) operations.

With the above correction operations, stable print quality is always provided, reducing service calls and service time.

2. Image forming section correction operation (Process correction operation)

The following are items of the image forming section correction operations (process correction operations).

a. List

Image forming section correction operations (process correction operations) list

Item No.	Correction operations	Purpose, effect	Execution conditions, operating timing
1	Image density sensor sensitivity correction (Calibration) (Gain adjustment)	Allows the image density sensor to always detect the correct image patch density.	Before process correction operation
2	OPC drum marking sensor sensitivity correction	Allows the OPC drum marking sensor to always detect the OPC drum marking normally.	* 1
3	Developing bias voltage correction	Prevents against density change and background copy.	* 1
4	Laser beam power correction 1	Prevent against a decrease in print density due to OPC drum membrane decrease.	Specified rotating time of the OPC drum: AR-250/280/281/285/286/335/336: Every 20,000 sec AR-405: Every 16,600 AR-501/505: Every 15,000
	Laser beam power correction 2	Outputs the laser beam power corresponding to the main charger grid voltage (to maintain the constant voltage).	Immediately after correction of the main charger grid voltage (* 1)
5	Main charger grid voltage correction 1	Corrects a decrease in the charging voltage due to the OPC drum membrane decrease, maintains the correct density of print and prevent against background copy.	Specified rotating time of the OPC drum: AR-250/280/281/285/286/335/336: Every 20,000 sec AR-405: Every 16,600 AR-501/505: Every 15,000
	Main charger grid voltage correction 2	Maintains the relations between the developing bias voltage and the main charger grid voltage at constant (to prevent against background copy).	Immediately after correction of the developing bias voltage (* 1)
6	Toner concentration correction	Maintains the normal toner concentration to maintain the proper density of print and prevent against background copy.	When the developing bias voltage correction is performed for the voltage higher than the specified level is made immediately after the developing bias voltage correction. (* 1)

- * 1 During warm-up after turning on the power.
During warm-up after cancelling SIM 7-1, 24-7, 25-2, 44-2.
After completion of printing when the accumulated print time reaches 30 min from the previous correction.
When the next print is made after the unit is idle for one hour.

3. Details

A. Operating conditions and timing of the image forming section correction operation (Process correction operation)

The image forming section correction operation (process correction operation) is performed under the following conditions and timing.

- 1) During warm-up after turning on the power.
- 2) During warm-up after cancelling SIM 7-1, 24-7, 25-2, 44-2.
- 3) After completion of printing when the accumulated print time reaches 30 min from the previous correction.
- 4) When the next print is made after the unit is idle for one hour.

B. Details of operations

(1) OPC drum marking sensor sensitivity adjustment (Calibration) and marking detection

a. Outline and purpose

The sensor sensitivity is adjusted to allow correct detection of the OPC drum marking.

b. Details (Calibration)

The sensor LED drive voltage (current) is changed, and when the sensor output voltage reaches the specified level, the sensor LED drive current control value is stored. In actual operations, the sensor LED is driven by the voltage corresponding to the control value and detection is performed.

(2) Image density sensor sensitivity adjustment (Calibration)

a. Outline and purpose

In the developing bias voltage correction, the image sensor sensitivity is adjusted to allow correct detection of the toner image patch density and normal operation of the developing bias voltage correction.

b. Details (Calibration)

The sensor LED drive voltage (current) is changed, and when the sensor output voltage reaches the specified level, the sensor LED drive current control value is stored. In actual operations, the sensor LED is driven by the voltage corresponding to the control value and detection is performed.

(3) Laser beam power correction 1

Deterioration of photo sensitivity due to deterioration of OPC drum is corrected by adjusting the laser beam power according to the OPC drum rotating time (operation time) to maintain the correct density print.

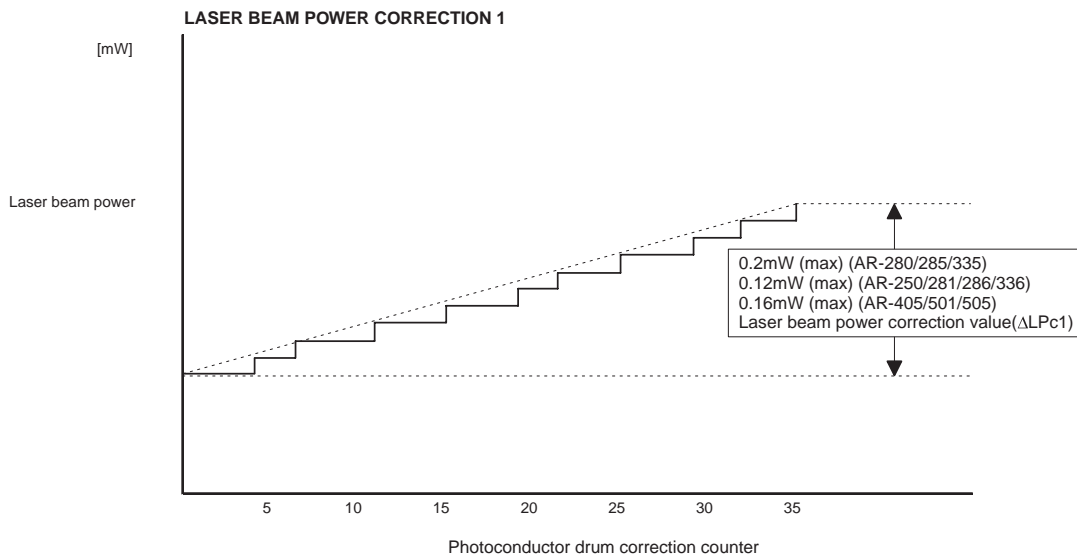

1 count: 20,000 sec (Photoconductor drum rotation time) (AR-250/280/281/285/286/335/336)
 16,600 sec (Photoconductor drum rotation time) (AR-405)
 15,000 sec (Photoconductor drum rotation time) (AR-501/505)

(4) Main charger grid voltage correction 1

The main charger grid voltage is increased according to deterioration of the OPC drum to maintain the proper density print and prevent against background copy.

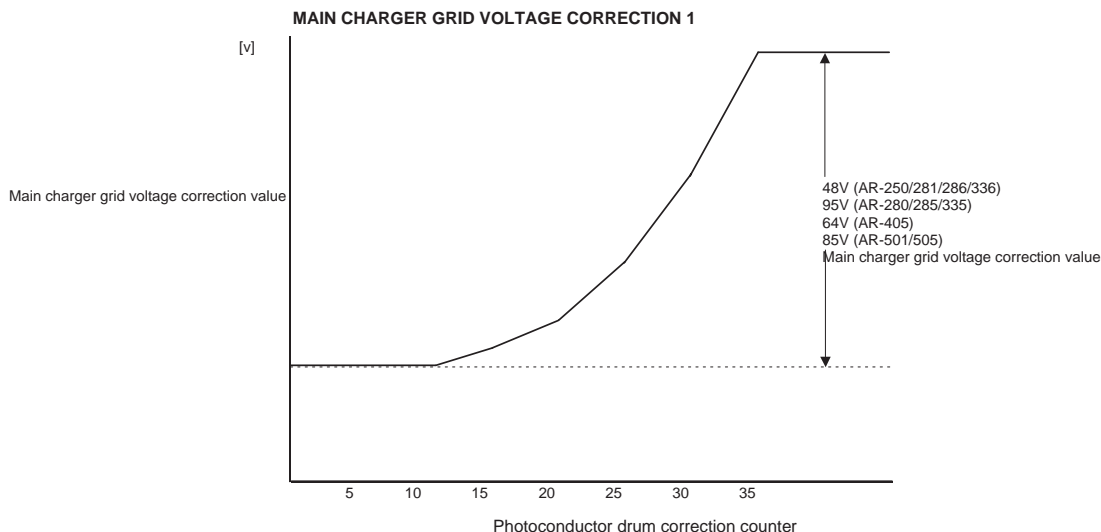

1 count: 20,000 sec (Photoconductor drum rotation time) (AR-250/280/281/285/286/335/336)
 16,600 sec (Photoconductor drum rotation time) (AR-405)
 15,000 sec (Photoconductor drum rotation time) (AR-501/505)

(5) Developing bias voltage correction

a. Outline and purpose

Deterioration of developer due to changes in the environmental conditions.

To solve the above problem, the developing bias voltage is changed according to the situation to maintain the proper density print and prevent against background copy.

(Operation)

1) Three toner image patches are made on the OPC drum with the three voltages V_{dbc} and $V_{dbc} \pm (n)\alpha$. ($\alpha = 50V$)

2) Connect the three points of three toner patch density points with straight lines, and check that it reaches the reference density.

If the above condition is satisfied, obtain the correction developing bias voltage ($V_{dbc}(n)$) for the reference density by linear approximation.

The reference density: 38 (set with SIM 44-4) for AR-280/285/335/405

58 (set with SIM 44-15) for AR-250/281/286/336

36 (set with SIM 44-4) for AR-501/505

3) Calculate the developing bias correction voltage ($\Delta V_{dbc}(n)$).

The developing bias correction voltage ($\Delta V_{dbc}(n)$) is applied to the developing bias voltage correction in all the operation modes.

If the condition of 2) is not satisfied, change the condition of 1) as follows and make three toner image patches similarly to 1).

(Contents of change)

Change the three developing bias voltages of correction for making toner image patches to $V_{dbc} + (n \pm 1)\alpha$, $V_{dbc} + (n \pm 2)\alpha$, and $V_{dbc} + (n \pm 3)\alpha$, and execute 1) and 2). ($\alpha = 50V$)

Repeat the above operation until the condition of 2) is satisfied. (n = Number of toner patch forming. 3 toner image patches are made at once.)

The correction operation of the developing bias voltage should be in the range of $0 \sim -750V$.

DEVELOPING BIAS VOLTAGE CORRECTION

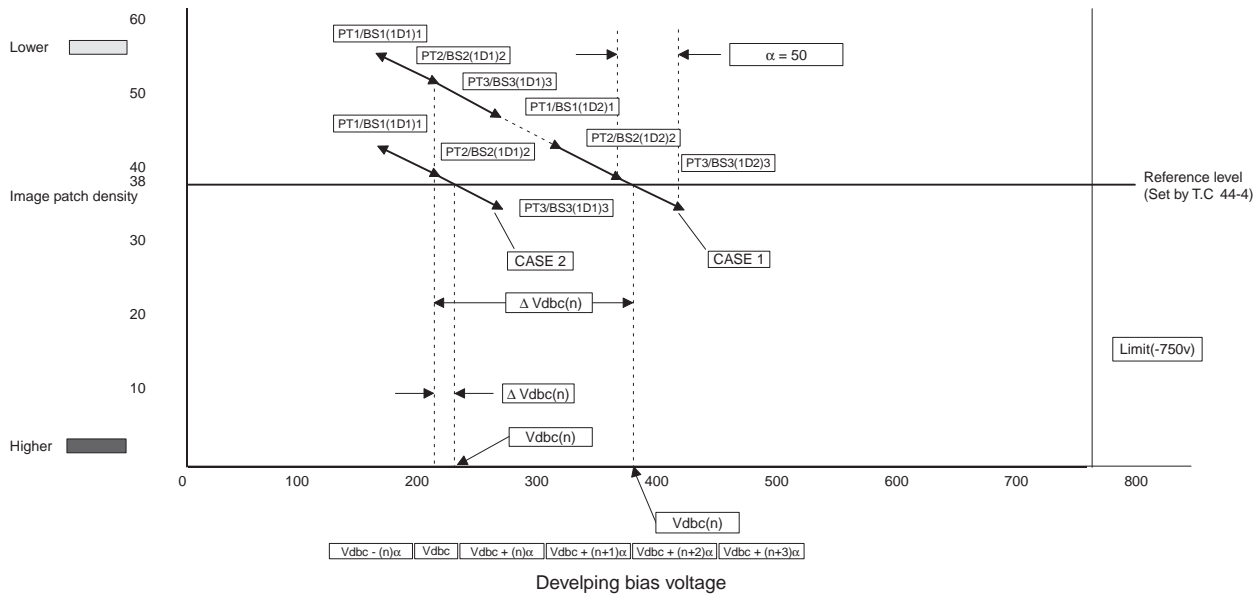

DEVELOPING BIAS VOLTAGE CORRECTION

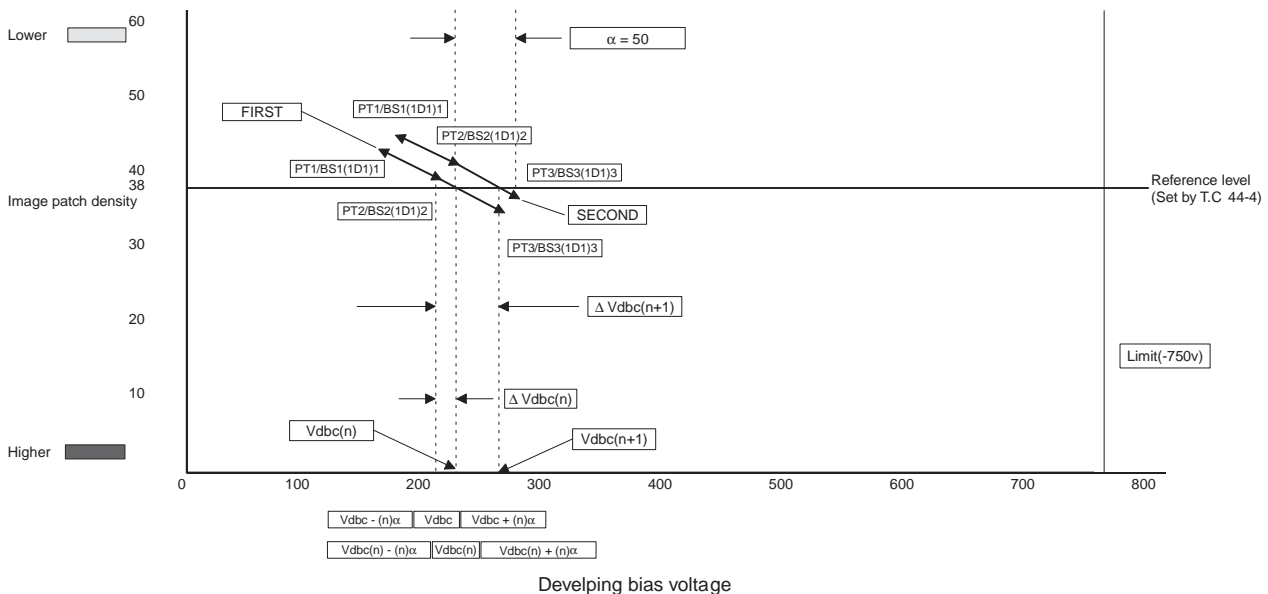

(6) Main charger grid voltage correction 2

a. Outline and purpose

When the developing bias voltage is changed, the main charger grid voltage correction 2 is performed to maintain the relation between the developing bias voltage and the main charger grid voltage at constant.

b. Details

After the developing bias voltage correction, the voltage of correction of the developing bias voltage is automatically added to the main charger grid voltage.

Actual main charger grid voltage variable range: -200 to -900V

(7) Laser beam power correction 2

To maintain the OPC drum bright potential at constant for changes in the main charger grid voltage due to main charger grid voltage correction 1 and 2, the laser beam power must be changed accordingly.

Laser beam power correction 2 is performed to output the laser beam power according to the above situation.

This correction provides stable print density.

(8) Toner concentration correction A

a. Outline and purpose

This correction is used to correct changes in the developer characteristics due to aging and change in the environmental conditions.

When any change occurs in the developer characteristics, it causes under-toner or over-toner, resulting in improper print density.

To prevent against this, the reference toner control level is changed according to the conditions to maintain the specified toner concentration.

This correction provides stable print density.

b. Details of operation

When the developing bias correction voltage ($\Delta V_{dbc}(n)$) is minus-corrected (shifted to the positive polarity direction), it is recognized as an increase in developing capability, and the reference toner concentration control level set with SIM 25-2 is increased.

With the above operation, toner concentration is decreased to maintain the proper print density.

The correction data is cleared to "0" when SIM 25-2 is executed.

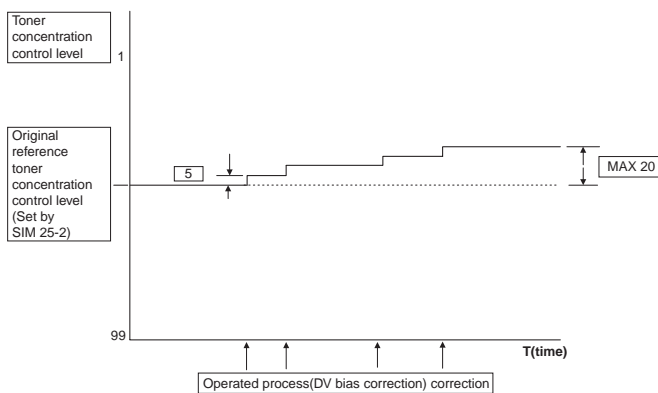

(9) Toner concentration correction B

a. Outline and purpose

Developer shows an inclination of overtoning with age. To prevent against this, the reference toner concentration control level is changed according to the situation to maintain the specified toner concentration level.

b. Details of operation

When the developer rotation time (SIM 44-9: DEVE MIXING TIME) reaches $A \times 1000\text{sec}$, the reference toner concentration level set with SIM 25-2 is increased by D count.

After that, correction by D count is made for every $B \times 1000\text{sec}$, and correction is ended up with C times of the number of times of correction.

The correction quantity can be changed with SIM 25-8. When shipping, correction is not used.

<Means>

The accumulated use time of developer is detected. When it reaches the specified level, the toner concentration control reference value is corrected (SIM 80-2).

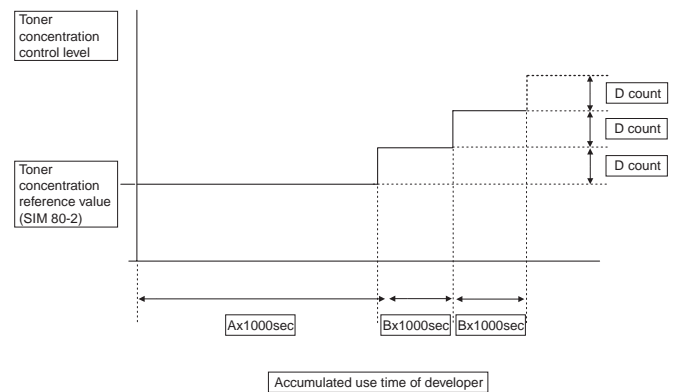

- This correction can be performed with SIM 25-8.
- The accumulated use time of developer is detected and displayed on the menu of SIM 44-9 similarly with the drum counter.
- The accumulated use time of developer is cleared after execution of SIM 25-2, and the counter is reset to 0sec. It, however, is not cleared with SIM 25-1.
- The accumulated use time of developer can be reset with SIM 24-11.
- The current correction quantity of toner concentration reference value is displayed on the menu of SIM 44-9 separately from toner concentration control correction A.
- The first correction time A can be set with a simulation and the default is 200. (Set range: 0 to 500)
- The second or later correction time B can be set with a simulation and the default is 50. (Set range: 0 to 300)
- The number of times of correction, C, can be set with a simulation and the default is 3. (Set range: 0 to 10)
- The correction quantity D can be set with a simulation and the default is 0. (Set range: 0 to 30)

4. RSPF

A. Operational descriptions

a. Simplex operation

- 1) Document set (2 pages)

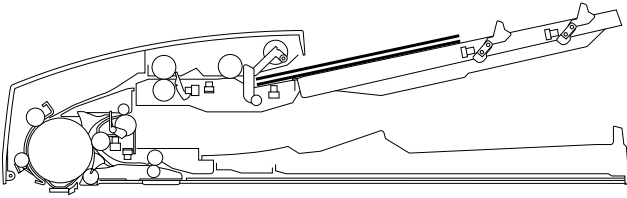

- 2) First page preliminary paper feed start

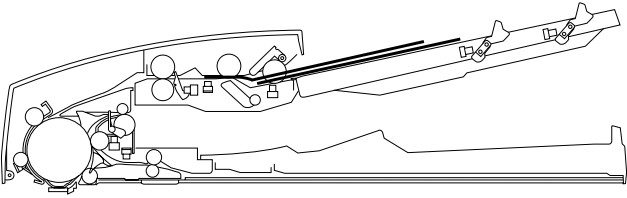

- 3) First page preliminary paper feed end

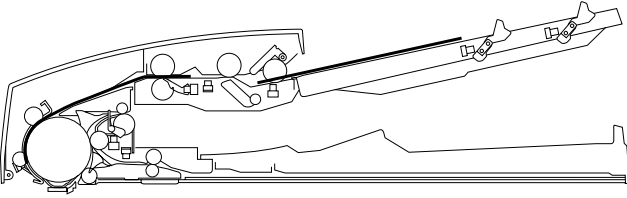

- 4) First page paper feed start

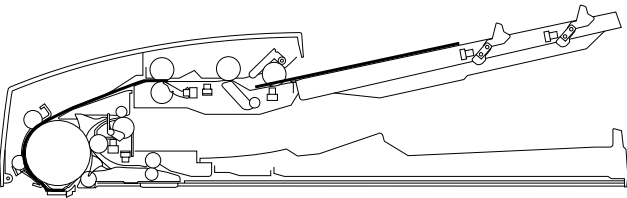

- 5) Second page preliminary paper feed start

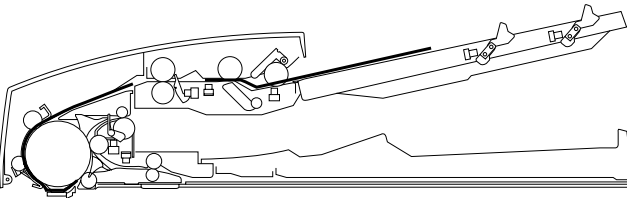

- 6) Second page preliminary paper feed end/First page paper feed end

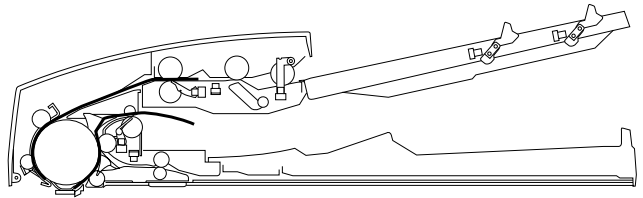

- 7) Second page paper feed start/First page paper exit end

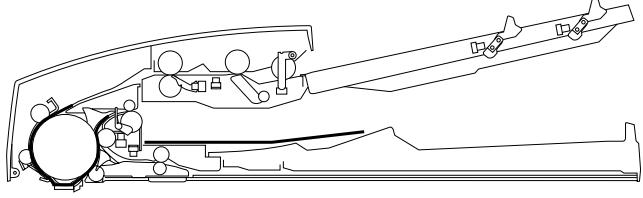

- 8) Second page paper exit start

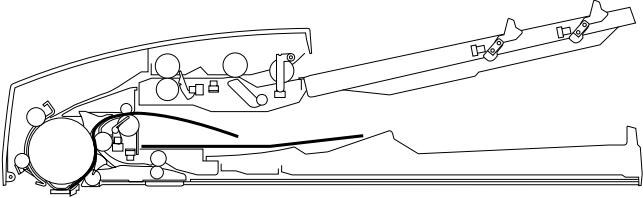

- 9) Second page paper exit end

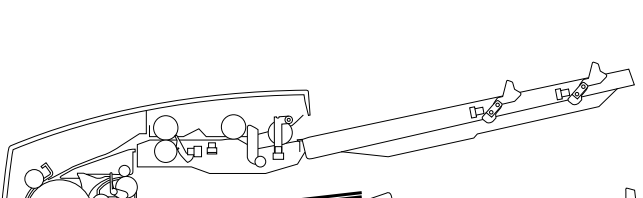

b. Duplex operation

- 1) Document set (2 pages)

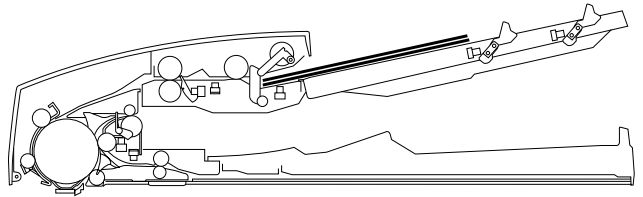

2) First page preliminary paper feed start

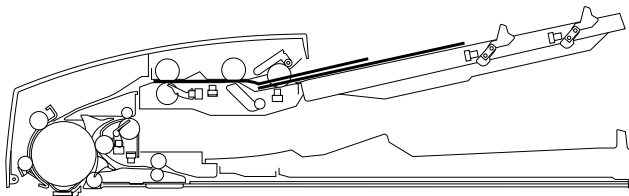

3) First page preliminary paper feed end

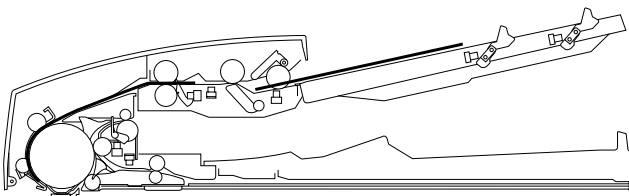

4) First page paper feed start (Front)

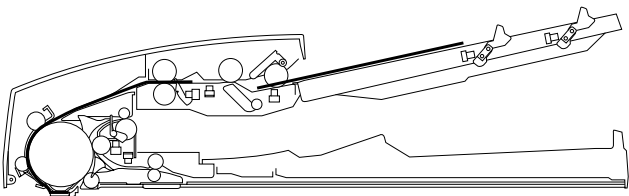

5) Second page preliminary paper feed start

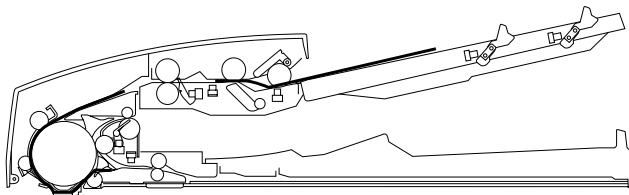

6) First page paper feed end (Front)

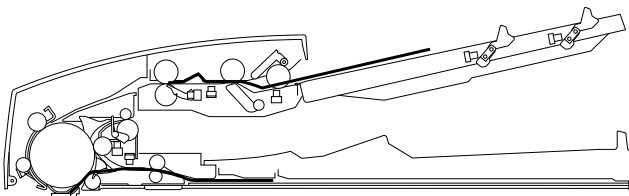

7) First page reverse start

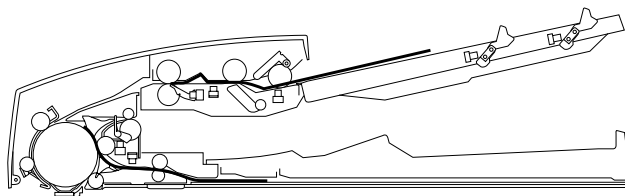

8) First page reverse end

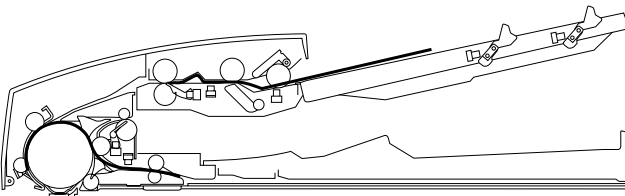

9) First page paper feed start (Back)/Second page preliminary paper feed resume

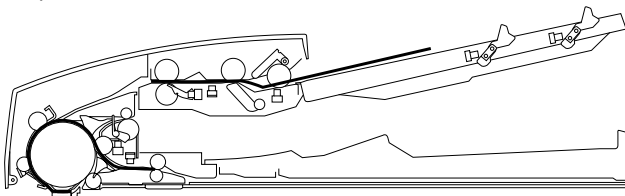

10) First page paper feed end (Back)

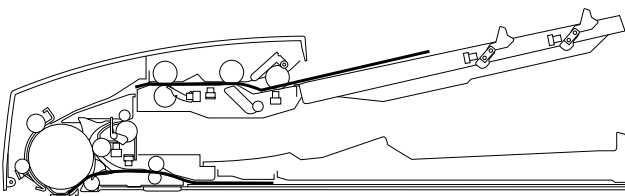

11) Second page preliminary paper feed resume/First page paper exit start

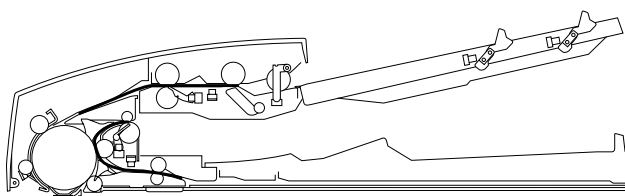

12) Second page preliminary paper feed end

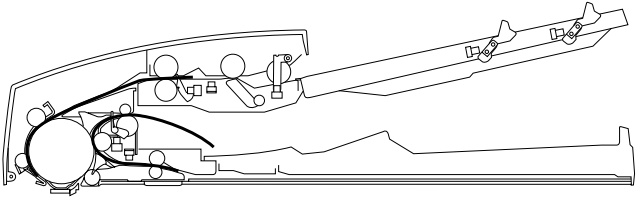

13) Second page paper feed start (Front)

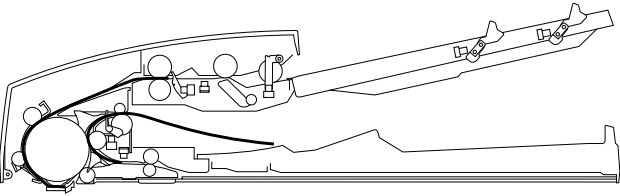

14) Second page paper feed end (Front)

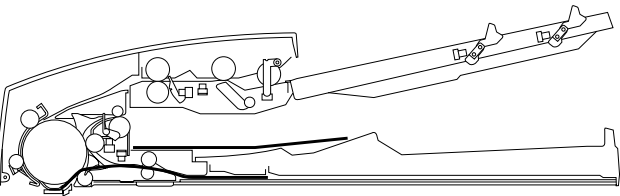

15) Second page reverse start

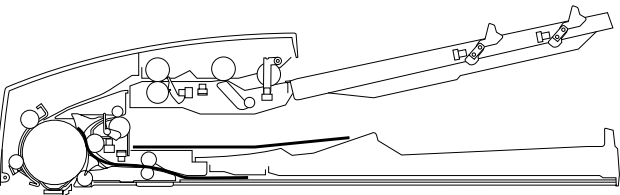

16) Second page reverse end

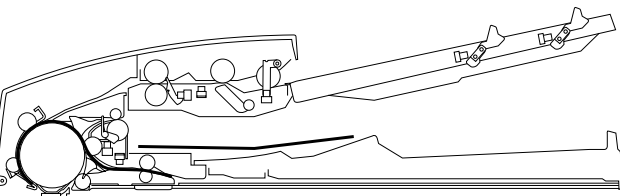

17) Second page paper feed start (Back)

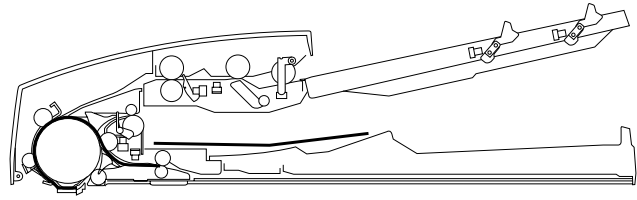

18) Second page paper feed end (Back)

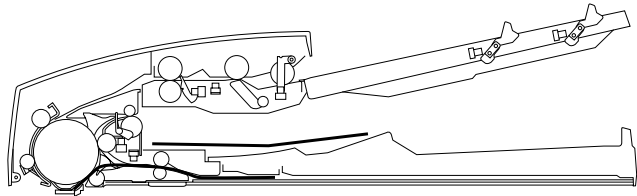

19) Second page paper exit start

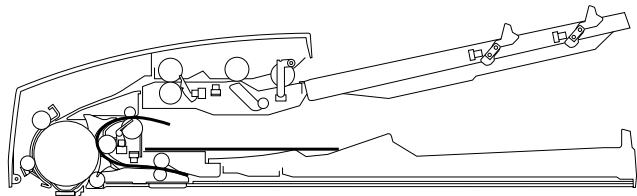

20) Second page paper exit end

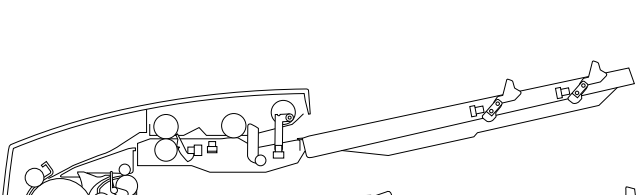

B. Document size detection method

This machine detects document sizes in the following three ways.

1) Document size detection by the document set tray

When documents are set in the document set tray, the size is detected to enable the automatic selection of the suitable paper and the copy magnification ratio according to the detected size.

When mixed sizes of documents are set, the max. size is detected. The document width is detected by TRVR (size volume), and the document length by TRS-S and TRS-L (tray sensors) to identify the document size.

The judgement of a document size is made at the timing when the empty sensor (EMPS) detects a document.

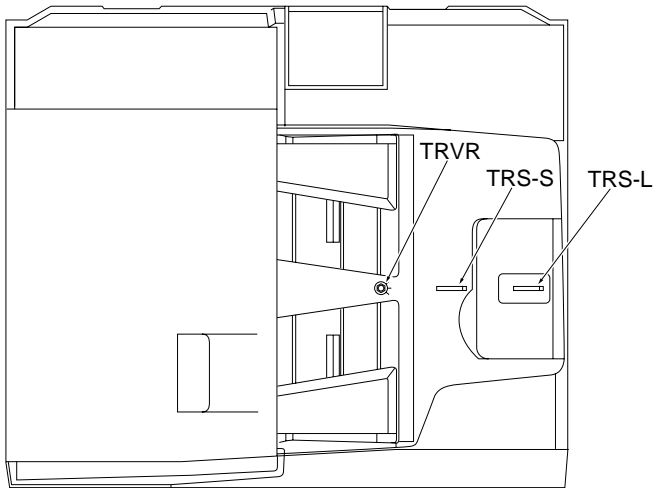

The document length is detected by counting the number of pulses of the paper feed motor (AMOT) and the transport motor (FMOT) during the time interval from when the paper feed motor (AMOT) starts rotation, that is, the resist roller starts rotation, and a document is fed from the paper feed section to the paper transport section to when the post-separation sensor (SPS) detects the rear edge of the document. With the detected document length and the document width detected by the size volume (TRVR), the document size is identified.

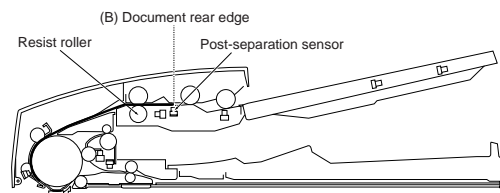
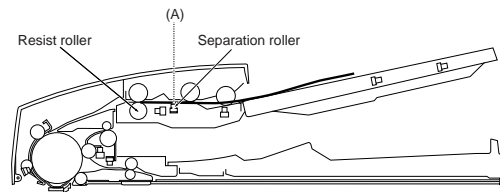

Document sizes and sensor states

	Document size and set direction	Sensor states (Detection level, or ON: μ, OFF: λ)		
		TRVR	TRS-S	TRS-L
INCH-1	B5R	1	μ	λ
	INV (5.5 × 8.5)	2	λ	λ
	LTR (8.5 × 11R)	2	μ	λ
	LGR (8.5 × 14R)	2	μ	μ
	B5	3	λ	λ
	B4R	3	μ	μ
	LT (8.5 × 11)	4	λ	λ
	WLTR (11 × 17R)	4	μ	μ
	A4	5	λ	λ
INCH-2	B5R	1	μ	λ
	INV (5.5 × 8.5)	2	λ	λ
	LTR (8.5 × 11R)	2	μ	λ
	L4R (8.5 × 13R)	2	μ	μ
	B5	3	λ	λ
	B4R	3	μ	μ
	LT (8.5 × 11)	4	λ	λ
	WLTR (11 × 17R)	4	μ	μ
	A4	5	λ	λ
SEEG SUK Japan	B5R	1	μ	λ
	LGR (8.5 × 14R)	2	μ	μ
	A5	2	λ	λ
	A4R	2	μ	λ
	B5	3	λ	λ
	B4R	3	μ	μ
	LT (8.5 × 11)	4	λ	λ
	WLTR (11 × 17R)	4	μ	μ
	A4	5	λ	λ
SCA	B5R	1	μ	λ
	F4R (8.5 × 13R)	2	μ	μ
	A5	2	λ	λ
	A4R	2	μ	λ
	B5	3	λ	λ
	B4R	3	μ	μ
	LT (8.5 × 11)	4	λ	λ
	WLTR (11 × 17R)	4	μ	μ
	A4	5	λ	λ
A3R	5	μ	μ	

2) Document size detection by the post-separation sensor (SPS)

This detection method supplements an incompleteness of document size detection on the document set tray when documents of different sizes are set together. Therefore, the detection result of this method has priority over that of the document set tray.

The number of pulses of the paper feed motor (AMOT) and the transport motor (FMOT) during the time interval between (A) and (B) is counted.

3) Document size detection by the read sensor (RDS)

This detection method supplements an incompleteness of document size detection on the document set tray when documents of same width but different length are set together (LTR/LGR judgement) or when document of a larger size than LT whose rear edge is not detected by the post-separation sensor (SPS) are set. Therefore, the detection result of this method has priority over that of the document size detection by the post-separation sensor.

When the transport motor (FOMT) rotates in the normal direction, the read roller start rotation and the document is fed from the paper feed section to the paper transport section. At that time, The number of pulses of the transport motor (FMOT) is counted while the read sensor reads the document from the lead edge to the rear edge, and the document length is detected from the count.

With the detected document length and the document width detected by the size volume (TRVR), the document size is identified.

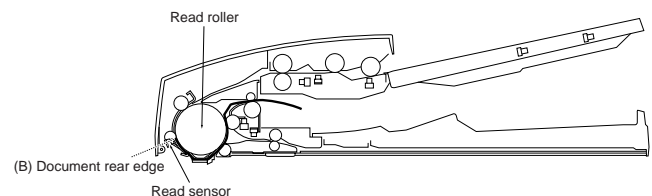
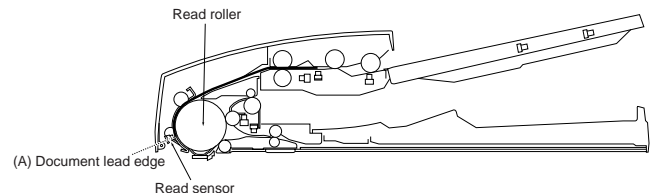

The number of pulses of the transport motor (FOMT) between (A) and (B).

CAUTION FOR BATTERY REPLACEMENT

(Danish)

ADVARSEL !

Lithiumbatteri – Eksplosionsfare ved fejlagtig håndtering.
Udskiftning må kun ske med batteri
af samme fabrikat og type.
Levér det brugte batteri tilbage til leverandoren.

(English)

Caution !

Danger of explosion if battery is incorrectly replaced.
Replace only with the same or equivalent type
recommended by the manufacturer.

Dispose of used batteries according to manufacturer's instructions.

(Finnish)

VAROITUS

Paristo voi räjähtää, jos se on virheellisesti asennettu.
Vaihda paristo ainoastaan laitevalmistajan suosittelemaan
tyyppiin. Hävitä käytetty paristo valmistajan ohjeiden
mukaisesti.

(French)

ATTENTION

Il y a danger d'explosion s' il y a remplacement incorrect
de la batterie. Remplacer uniquement avec une batterie du
même type ou d'un type équivalent recommandé par
le constructeur.

Mettre au rebut les batteries usagées conformément aux
instructions du fabricant.

(Swedish)

VARNING

Explosionsfara vid felaktigt batteribyte.
Använd samma batterityp eller en ekvivalent
typ som rekommenderas av apparatillverkaren.
Kassera använt batteri enligt fabrikantens
instruktion.

SHARP

COPYRIGHT © 1999 BY SHARP CORPORATION

All rights reserved.

Printed in Japan.

No part of this publication may be reproduced,
stored in a retrieval system, or transmitted,
in any form or by any means,
electronic; mechanical; photocopying; recording or otherwise
without prior written permission of the publisher.

SHARP CORPORATION
Digital Document Systems Group
Quality & Reliability Control Center
Yamatokoriyama, Nara 639-1186, Japan

1999 August Printed in Japan